

6.7 ft x 7.8 ft MERIDIAN GREENHOUSE

Installation and Operating Instructions – YM11945X



HEIGHT:
2.36m / 7' 9"

IMPORTANT, RETAIN FOR FUTURE REFERENCE: READ CAREFULLY

11-07-2024

**YARDISTRY®**

Yardistry – North America
Toll Free Customer Support:
1.888.509.4382
info@yardistrystructures.com
www.yardistrystructures.com

Patents Pending

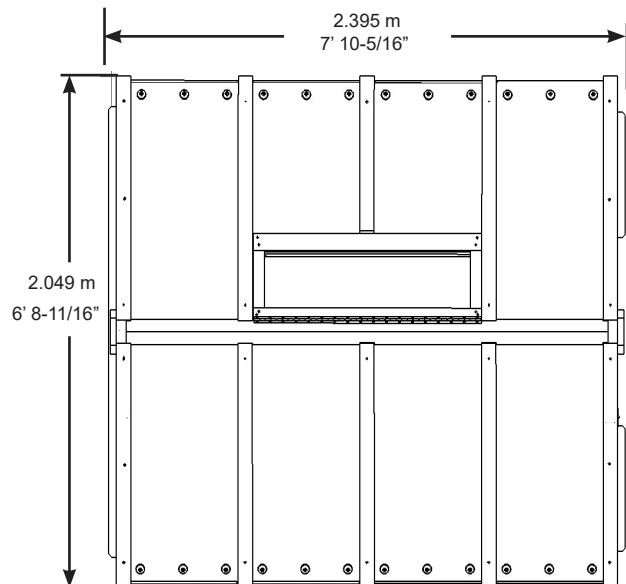

Important Safety Notice!

Yardistry components are intended for privacy, decorative and ornamental use only.

Product is NOT INTENDED for the following:

- A safety barrier to prevent unsupervised access to pools, hot tubs, spas or ponds.
- As load bearing support for a building, structure, heavy objects or swings.
- Used in structures that trap wind, rain or snow that would create extra load on the product.

Accumulated snow must be removed from roof.

DO NOT climb or walk on roof for any reason.

Permanent structures may require a building permit. As the purchaser and or installer of this product you are advised to consult local planning, zoning and building inspection departments for guidance on applicable building codes and/or zoning requirements.

Wood is NOT flame retardant and will burn. Grills, fire pits and chimineas are a fire hazard if placed too close to a Yardistry structure. Consult user's manual of the grill, fire pit or chiminea for safe distances from combustible materials.

Wear gloves to avoid injury from possible sharp edges of individual elements before assembly.

During installation, follow all safety warnings provided with your tools and use OSHA approved safety glasses. Some structures may require two or more people to install safely.

Check for underground utilities before digging or driving stakes into the ground!

During assembly it is important to closely follow the instructions. Complete the assembly on a solid, level surface and follow the instructions to square up, level and anchor the structure. This will reduce the gaps at wood connections during assembly.

General Information

General Information: Wood components are manufactured with premium outdoor lumber (c.lanceolata) which is protected with factory applied water-based stain. Knots, small checks (cracks) and weathering are naturally occurring and do not affect the strength of the product. Annual application of a water-based water repellent sealant or stain is important and will help reduce weathering and checks.

www.yardistrystructures.com

Questions?

Call toll free or write us at:

1 (888) 509-4382

support@yardistrystructures.com

Regular Hours: Mon - Fri, 8:30 am - 5:00 pm EST
(excl. holidays)

English and French Spoken

(For extended hours see our website)

www.yardistrystructures.com

Patents Pending

Limited Warranty

Yardistry warrants that this product is free from defect in materials and workmanship for a period of one (1) year from the original date of purchase. In addition, for any product with lumber, all lumber is warranted for five (5) years against rot and decay. Polycarbonate panels are warranted for five (5) years against defect in materials and workmanship. This warranty applies to the original owner and registrant and is non-transferable.

Regular maintenance is required to assure the integrity of your product and is a requirement of the warranty. This warranty does not cover any inspection costs.

This Limited Warranty does not cover:

- Labor for replacement of any defective item(s);
- Incidental or consequential damages;
- Cosmetic defects which do not affect performance or integrity;
- Vandalism; improper use or installation; acts of nature, including but not limited to wind, storms, hail, floods, excessive water exposure;
- Minor twisting, warping, checking or any other natural occurring properties of wood that do not affect performance or integrity.

Yardistry products have been designed for safety and quality. Any modifications made to the original product could damage the structural integrity of the product leading to failure and possible injury. Yardistry cannot assume any responsibility for modified products. Furthermore, modification voids any and all warranties.

This product is warranted for RESIDENTIAL USE ONLY. Yardistry disclaims all other representations and warranties of any kind, express or implied.

This Warranty gives you specific legal rights. You may have other rights as well which vary from state to state or province to province. This warranty excludes all consequential damages, however, some states/provinces do not allow the limitation or exclusion of consequential damages, and therefore this limitation may not apply to you.

Instructions for Proper Maintenance

Your Yardistry structure is designed and constructed of quality materials. As with all outdoor products it will weather and wear. To maximize the enjoyment, safety and life of your structure it is important that you, the owner, properly maintain it.

HARDWARE:

- Check metal parts for rust. If found, sand and repaint using a non-lead paint complying with 16 CFR 1303.
- Inspect and tighten all hardware after completion of assembly; after first month of use; and then annually. Do not over-tighten as to cause crushing and splintering of wood.
- Check for sharp edges or protruding screw threads, add washers if required.

WOOD PARTS:

- Applying a water repellent or stain (water-based) on a yearly basis is important maintenance to maintain maximum life and performance of the product.
- Check all wood members for deterioration, structural damage and splintering. Sand down splinters and replace deteriorated wood members. As with all wood, some checking and small cracks in grain is normal
- Some gapping may occur at some wood connections.

POLYCARBONATE PANELS:

- Clean panels with mild soap and water using a soft cloth or sponge.
- Inspect silicone seal around each panel for separation. Reapply silicone seal as needed.
- Condensation may occur as temperature and humidity levels fluctuate. Condensation is temporary and will evaporate on its own. Proper ventilation can help to reduce condensation inside the Greenhouse.

SINGLE SPRING ALUMINUM WINDOW OPENER:

- At the end of the warm weather season the cylinder must be removed from the greenhouse and stored in a dry place.
- Lubricate the cylinder before re-installing each time.

Assembly Guides

Tools Required:

- | | | |
|------------------------------|------------------|------------------|
| • Tape Measure | • Hard Hat | • 6' Step Ladder |
| • Carpenters Level | • Safety Glasses | • Square |
| • Standard or Cordless Drill | • Adult Helper | • Caulking Gun |
| • Claw Hammer | • Safety Gloves | |

Symbols:

Throughout these instructions symbols are provided in the top, right-hand corner of the page.



- Use Help, where this is shown, 2, 3 or 4 people are required to safely complete this step. To avoid injury or damage to the assembly make sure to get some help.



- Use a measuring tape to assure proper location



- Pre-drill a pilot hole before fastening screw or lag to prevent splitting of wood.



- Check that assembly is square before tightening bolts

If you dispose of your Yardistry structure: Please disassemble and dispose of your unit so that it does not create any unreasonable hazards at the time it is discarded. Be sure to follow your local waste ordinances.

Assembly Tips

Following are some helpful tips to make the assembly process smooth and efficient.

PRE-ASSEMBLIES:

- Work on a raised, solid and flat surface such as, a table or saw horse.
- Keep all connections flush where shown in the instructions.
- When assembling, keep parts flat, straight and snug when connecting.

POLY CARBONATE PARTS:

- Material may have sharp edges, wear safety gloves.
- Remove all plastic covering, on both sides of the poly carbonate panels, directly before installing each piece.
- Place poly carbonate parts on a non-abrasive surface before and after assembly as it can bend, dent and scratch easily.
- When standing on the outside of the unit, the notch in the poly carbonate panel needs to be on the bottom right-hand side.
- Remove protective film immediately before installing panels.

TAPE:

- Do not substitute tape.
- Tape should be applied in temperatures above 10°C (50°F).

SINGLE SPRING ALUMINUM WINDOW OPENER:

- Before installing, place black cylinder in the refrigerator for approximately 5-7 minutes or until cylinder rod has fully retracted.
- Automatic ventilation will not occur in temperatures above 50°C (122°F).
- The Aluminum Single Spring Window Opener is designed to automatically open and close with changes in temperature. It must not be opened or closed manually. Doing so will result in damage to the component

GUIDE SPACERS:

- Included to help align grooves in wood parts to properly install poly carbonate panels.

WINTER AND HIGH WIND PREPARATION:

- Any accumulated snow must be removed from roof.

Sealant Application Tips, Warning and First Aid Information

SEALANT:

- All surfaces to be clean, dry, dust and grease free before application with temperatures above 5°C (41°F), no warmer than 35°C (95°F).
- Cut tip off sealant tube, attach supplied nozzle and use a caulking gun to apply small beads. See below images.
- Apply sealant in small beads and smooth as required.
- To smooth sealant into the joint use a glove covered finger, putty knife, etc. Smooth sealant to create a continuous water-tight seal.
- Clean excess with a cloth or paper towel before it skins over.
- An initial bond will set in approximately 20 minutes and fully set in 24 hours.

WARNING:

- CAUSES SERIOUS EYE AND SKIN IRRITATION. Always wear safety glasses and rubber gloves when using product.
- KEEP OUT OF REACH OF CHILDREN.
- Prolonged or repeated exposure MAY CAUSE ORGAN DAMAGE. Provide ample ventilation.

FIRST AID:

- If ingested, DO NOT INDUCE VOMITING. Seek immediate medical attention.
- Eye contact: immediately flush eyes with water for at least 15 minutes. Remove contact lenses if present.
- Skin contact; wash thoroughly with soap and water. If eye/skin irritation persists or respiratory symptoms occur or develop, seek medical attention.

Use of this product can expose you to chemicals including Methanol, which is known to the State of California to cause birth defects and other reproductive harm. For more information, go to www.P65Warnings.ca.gov.

Dispose of contents and container in accordance with local regulations.

Step 1: Cut off tip of tube

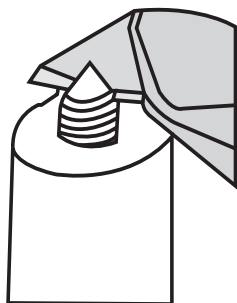

Step 2: Attached supplied nozzle

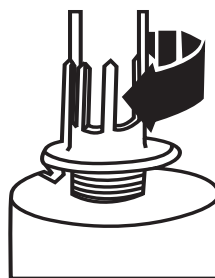

Step 3: Put tube in caulking gun

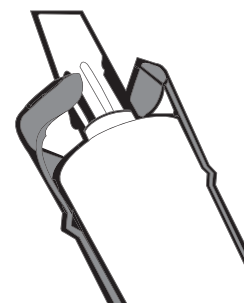

Structure Location Preparation

Note: It is critically important you start with square, solid and level base to attach your Greenhouse.

The hardware to mount the structure permanently will need to be purchased separately at your local hardware store.

Before preparing your surface for the structure please double check for possibility of any underground utilities such as gas, telephone, cable or sprinkler lines.

Choose a level piece of land with good drainage and lots of sunlight. Ensure it is easy to get around for essential cleaning and maintainance.

Remove any sod, grass, weeds, etc. from the area. Start with a packed and level dirt floor.

The recommended area for site preparation is 92" L x 75-1/2" W (2.337m L x 1.918m W) for this structure.

Refer to your local building and city codes, ordinances, neighbourhood covenants, or height restrictions regarding this type of structure for guidance on acceptable installation requirements.

Following are some examples of how to prepare the location for the structure.

If you are using a soft, natural base, the following will be needed:

- Sand
- Landscape fabric
- 4 x 4 treated lumber for the base of the structure
- Hardware for attaching lumber together
- Hardware for mounting the structure to the lumber base
- Gravel
- Tie down kit

If you are using a concrete foundation, the following will be needed:

- Hardware for mounting the structure to the concrete base

Use the following dimensions for the concrete foundation.

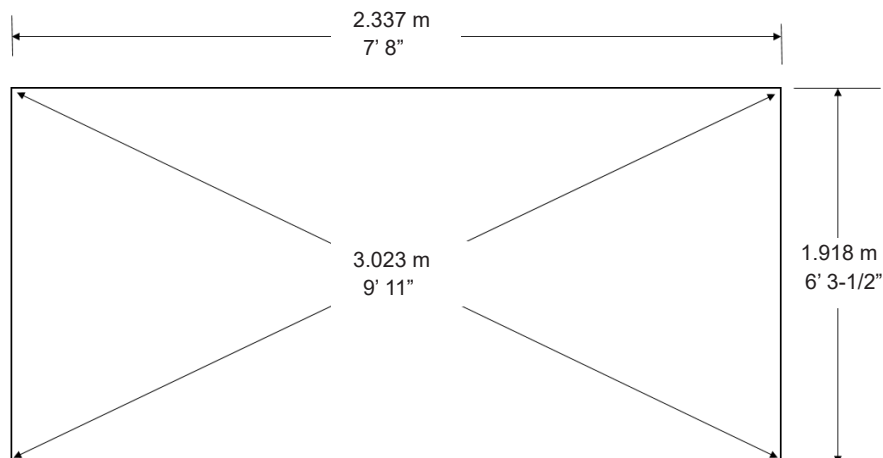

Part Identification (Dimensions are approximate and are shown to assist in the identification of parts for assembly. Actual dimensions may be smaller or larger.)

2pc. (1108) - Left Post 66.7 x 76.2 x 1835.2mm (72-1/4") Y50131-1108

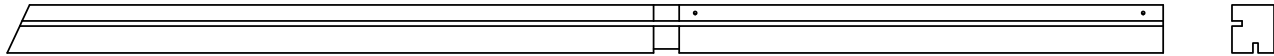

2pc. (1109) - Right Post 66.7 x 76.2 x 1835.2mm (72-1/4") Y50131-1109



1pc. (1111) - Left Door Post 38.1 x 66.7 x 1974.9mm (77-3/4") Y50131-1111

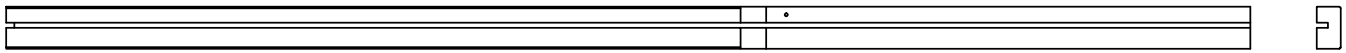

1pc. (1112) - Right Door Post 38.1 x 66.7 x 1974.9mm (77-3/4") Y50131-1112

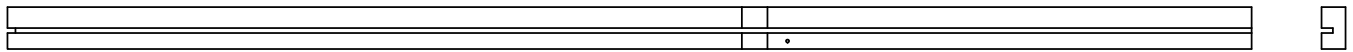

1pc. (1119) - Front Base 38.1 x 66.7 x 1905mm (75") Y50131-1119

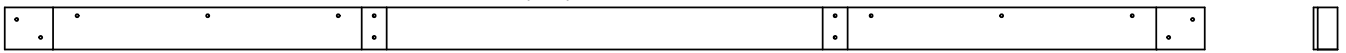

1pc. (1143) - Front Gable Beam 66.7 x 76.2 x 1192.2mm (46-15/16") Y50131-1143

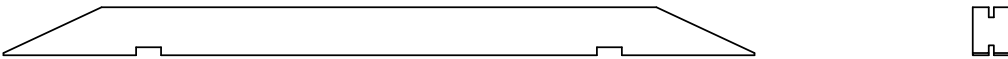

2pc. (1116) - Left Roof Rafter 66.7 x 76.2 x 1079.5mm (42-1/2") Y50131-1116



2pc. (1115) - Right Roof Rafter 66.7 x 76.2 x 1079.5mm (42-1/2") Y50131-1115

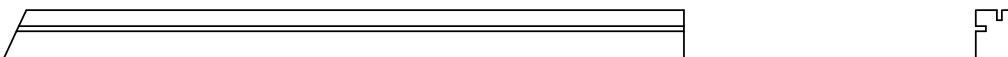

2pc. (1105) - Front Wall Sill 38.1 x 101.6 x 503.4mm (19-13/16") Y50131-1105

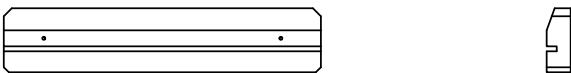

2pc. (1184) - Peak Spacer 73 x 152.4 x 177.8mm (7") Y70131-1184



Part Identification (Dimensions are approximate and are shown to assist in the identification of parts for assembly. Actual dimensions may be smaller or larger.)

2pc. (1113) - Back Post 76.2 x 66.7 x 1974.9mm (77-3/4") Y50131-1113



1pc. (1120) - Back Base 38.1 x 66.7 x 1905mm (75") Y50131-1120

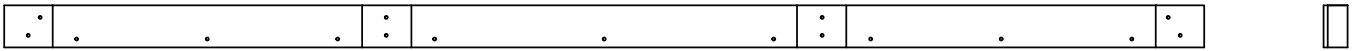

1pc. (1117) - Back Gable Beam 66.7 x 76.2 x 1192.2mm (46-15/16") Y50131-1117



1pc. (1106) - Back Wall Sill 38.1 x 101.6 x 1803.4mm (71") Y50131-1106

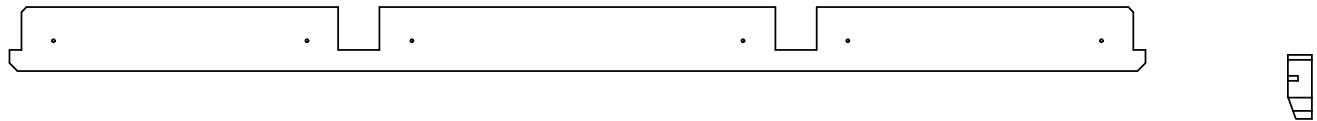

2pc. (1122) - Upright Outside 25.4 x 101.6 x 177.8mm (7") Y50131-1122



2pc. (1121) - Upright Inside 34.9 x 101.6 x 177.8mm (7") Y50131-1121



4pc. (1136) - Inside Vent Trim 38.1 x 38.1 x 324.8mm (12-3/4") Y50131-1136

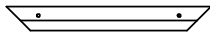

4pc. (1147) - F/B Panel 41.3 x 504.8 x 762mm (30") Y70131-1147

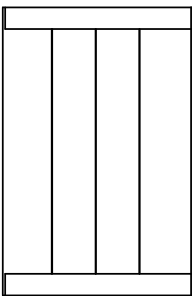

1pc. (1155) - Vent Wall Panel 57.2 x 622.7 x 762mm (30") Y70131-1155

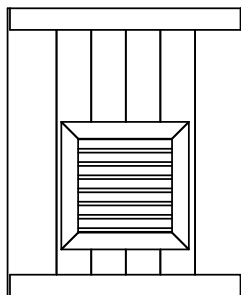

Part Identification (Dimensions are approximate and are shown to assist in the identification of parts for assembly. Actual dimensions may be smaller or larger.)

2pc. (1110) - Mid Post 66.7 x 76.2 x 1835.2mm (72-1/4") **Y50131-1110**

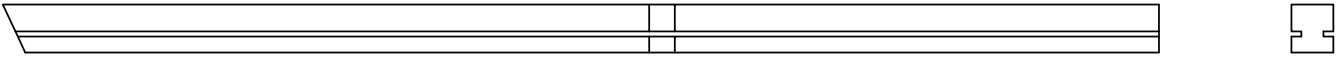

2pc. (1118) - Side Base 38.1 x 76.2 x 2190.8mm (86-1/4") **Y50131-1118**

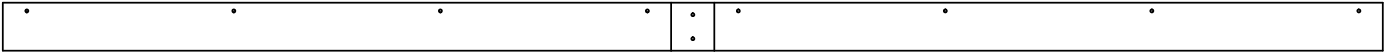

4pc. (1107) - Side Wall Sill 38.1 x 101.6 x 1112.8mm (43-13/16") **Y50131-1107**

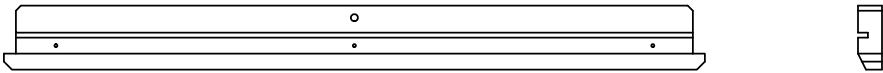

5pc. (1114) - Middle Roof Rafter 66.7 x 76.2 x 1079.5mm (42-1/2") **Y50131-1114**

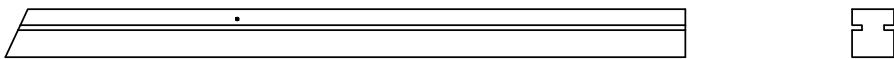

1pc. (1123) - Roof Peak 50.8 x 88.9 x 2235.2mm (88") **Y70131-1123**



1pc. (1124) - Vent Roof Peak 50.8 x 88.9 x 2235.2mm (88") **Y70131-1124**

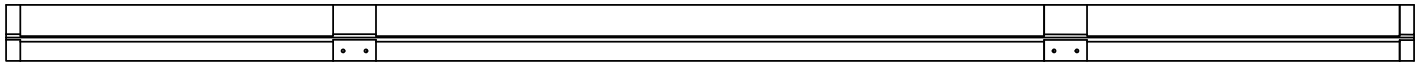

2pc. (1125) - Side Wall Top 44.5 x 114.3 x 2235.2mm (88") **Y70131-1125**

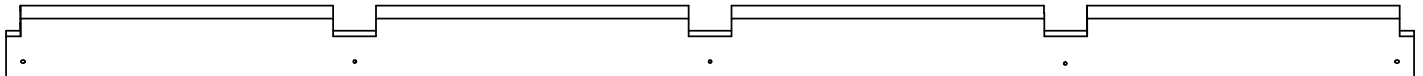

4pc. (1144) - Short Post Assembly 66.7 x 76.2 x 1047.8mm (41-1/4") **Y70131-1144**

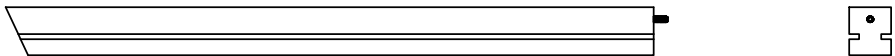

4pc. (1152) - Side Wall Panel 41.3 x 1073.2 x 762mm (30") **Y70131-1152**

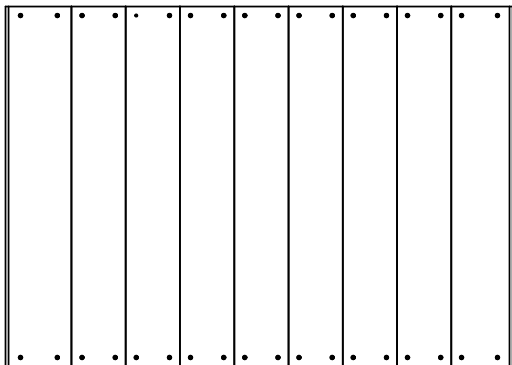

Part Identification (Dimensions are approximate and are shown to assist in the identification of parts for assembly. Actual dimensions may be smaller or larger.)

1pc. (1187) - Vent Roof Panel Block 15.9 x 34.9 x 1003.3mm (39-1/2") Y50131-1187



2pc. (1188) - Guide Spacer 7 x 63.5 x 262mm (10-5/16") Y50100-1188



2pc. (1126) - Inside Vent Block 25.4 x 44.5 x 328mm (12-15/16") Y50131-1126

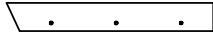

1pc. (1127) - Vent Roof Rafter 66.7 x 76.2 x 692.2mm (27-1/4") Y50131-1127

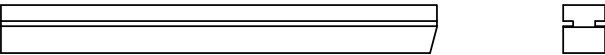

1pc. (1128) - Bottom Vent Block 38.1 x 44.5 x 1061.6mm (41-3/4") Y50131-1128

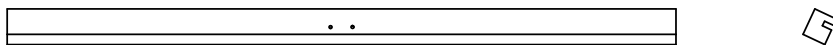

1pc. (1170) - Vent Roof Panel 31.8 x 379.4 x 1055.7mm (41-9/16") Y70131-1170

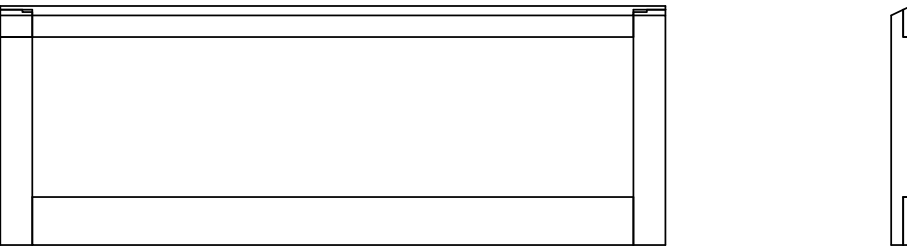

5pc. (1134) - Shelf Gusset 34.9 x 44.5 x 536.6mm (21-1/8") Y50131-1134

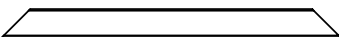

8pc. (1131) - Shelf Top 15.9 x 88.9 x 1751mm (68-15/16") Y50131-1131



2pc. (1132) - Shelf Front 25.4 x 76.2 x 1752.6mm (69") Y50131-1132

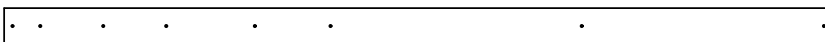

1pc. (1133) - Shelf Side 28.6 x 63.5 x 558.8mm (22") Y50131-1133

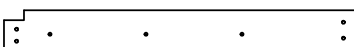

6pc. (1135) - Shelf Joist 34.9 x 44.5 x 381mm (15") Y50131-1135

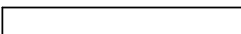

2pc. (1137) - Long Shelf Joist 34.9 x 44.5 x 406.4mm (16") Y50131-1137

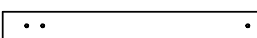

Part Identification (Dimensions are approximate and are shown to assist in the identification of parts for assembly. Actual dimensions may be smaller or larger.)

8pc. (1138) - Wooden Gusset 34.9 x 139.7 x 203.2mm (8") Y50131-1138



2pc. (1139) - Short Upper Shelf 15.9 x 101.6 x 1822.5mm (71-3/4") Y50131-1139



2pc. (1140) - Long Upper Shelf 15.9 x 101.6 x 1993.2mm (78-1/2") Y50131-1140



1pc. (1141) - Shelf Block 34.9 x 101.6 x 203.2mm (8") Y50131-1141



1pc. (1142) - Closer Block 34.9 x 139.7 x 152.4mm (6") Y50131-1142

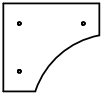

1pc. (1129) - Top Door Block 19.1 x 25.4 x 690mm (27-3/16") Y50131-1129

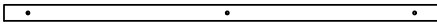

2pc. (1130) - Door Block 19.1 x 25.4 x 1935.2mm (76-3/16") Y50131-1130

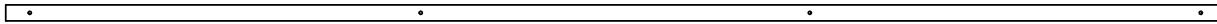

1pc. (1175) - Door Panel 38.1 x 673.1 x 1943.1mm (76-1/2") Y70131-1175

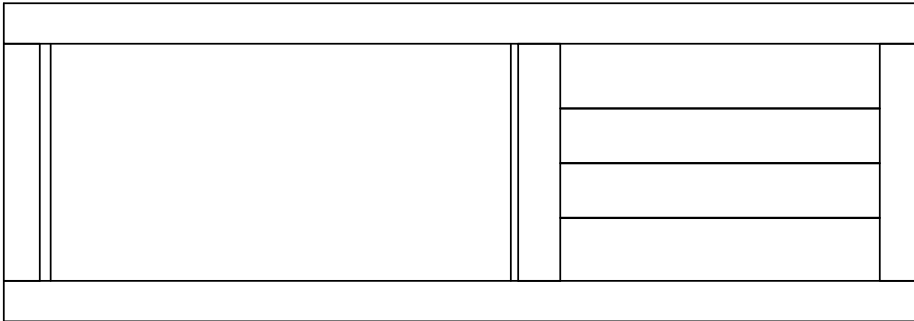

1pc. (8PK) Side Wall Panel (Y70800-424)

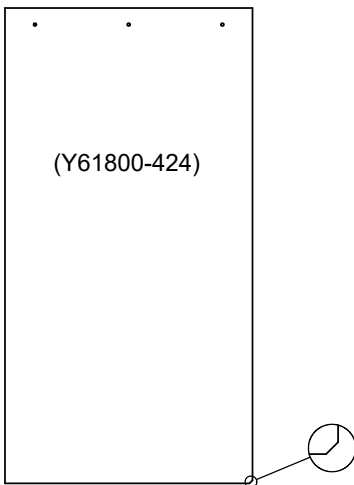

1pc. (2PK) Small Roof Panel (Y70800-426)

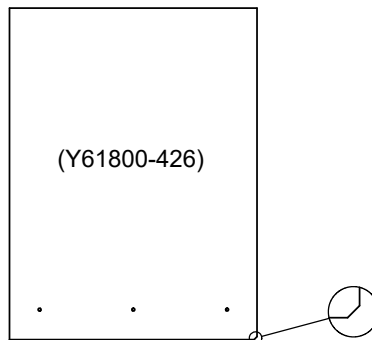

1pc. (6PK) Roof Panel (Y70800-425)

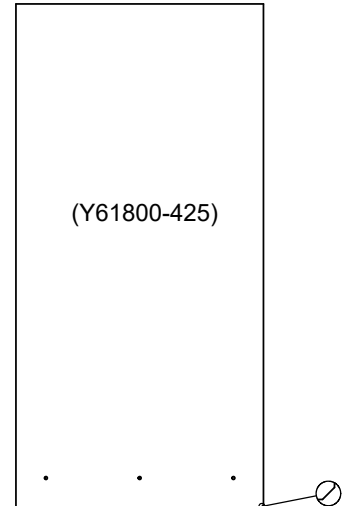

Part Identification (Dimensions are approximate and are shown to assist in the identification of parts for assembly. Actual dimensions may be smaller or larger.)

1pc. (2PK) Left F/B Side Panel
(Y70800-428)

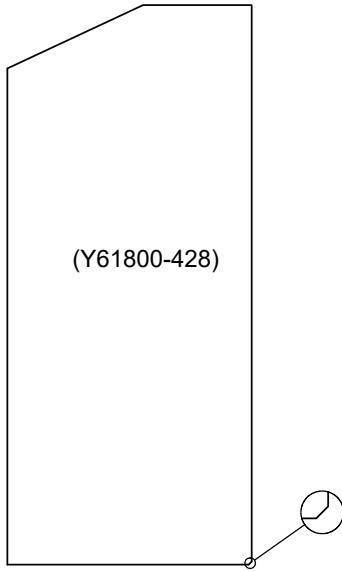

1pc. (2PK) Right F/B Side Panel
(Y70800-427)

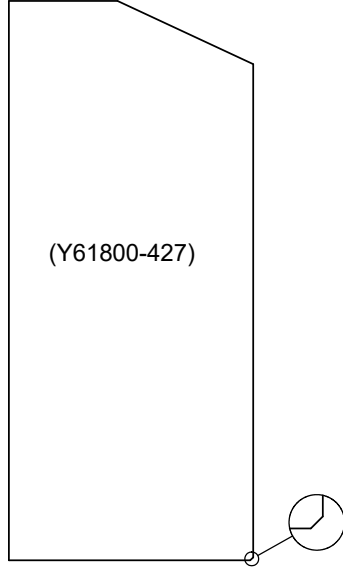

1pc. Back Centre Panel
(Y61800-429)

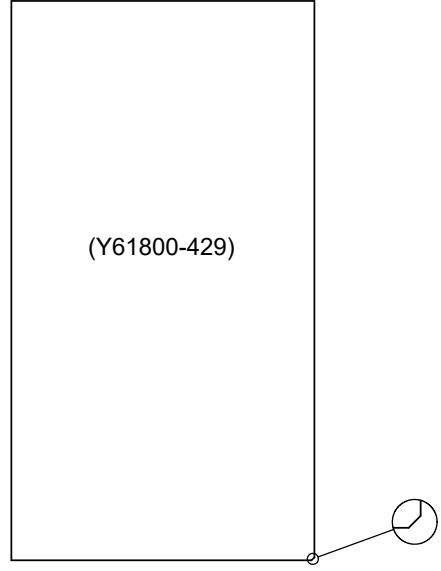

1pc. (2PK) Gable Panel
(Y70800-430)

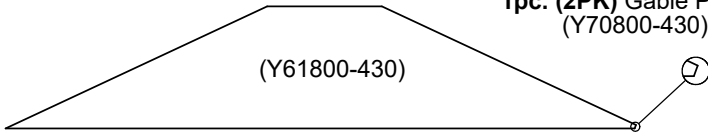

1pc. (2PK) Tape Set
1-Top application 2-Bottom application
(Y70812-437)

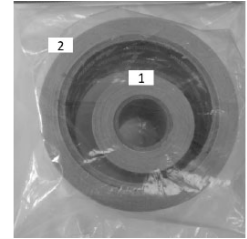

1pc. (48PK) EPDM Washer
(Y70812-444)

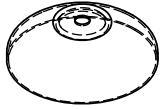

1pc. (16PK) PC U Channel
(Y70800-436)

3pc. Silicone Clear - 300ml Tube
(Y90100-002)



1pc. Gazebo ID Plaque
(Y70800-104)

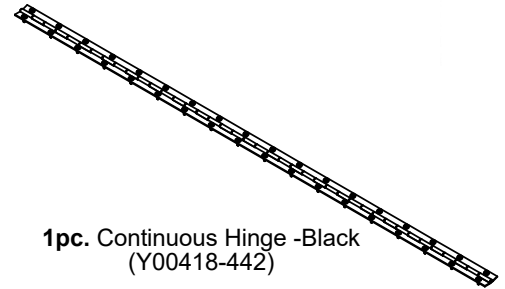

1pc. Continuous Hinge -Black
(Y00418-442)

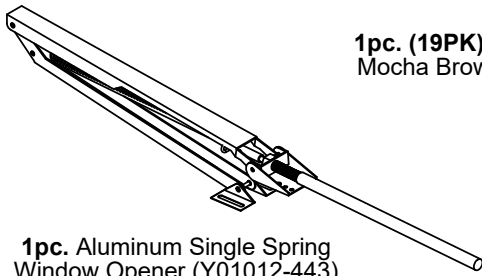

1pc. Aluminum Single Spring Window Opener
(Y01012-443)

1pc. (19PK) Corner Bracket - Mocha Brown
(Y70829-435)

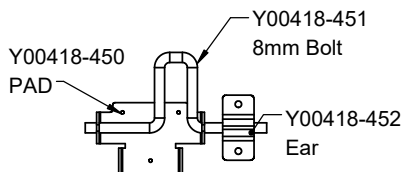

1pc. Sliding Barrel Bolt -Black
(Y70818-440)

1pc. 3 inch Square Hinge-Black
3 PK (Y70818-439)

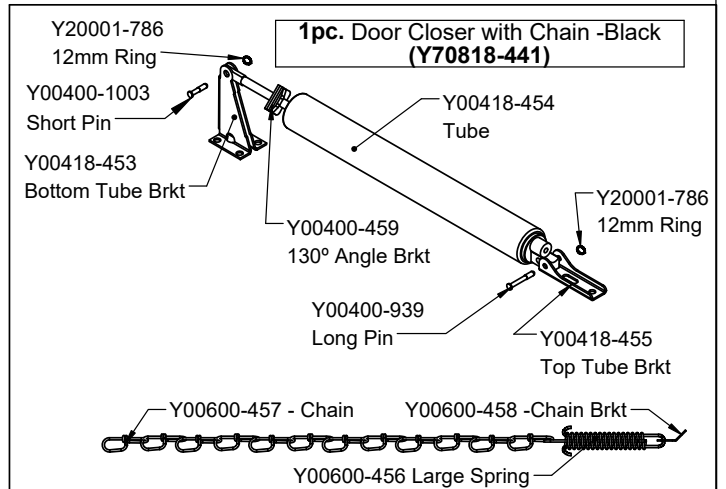
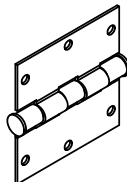

Hardware Identification (Dimensions are approximate and are shown to assist in the identification of parts for assembly. Actual dimensions may be smaller or larger.)

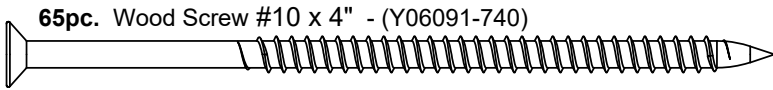

65pc. Wood Screw #10 x 4" - (Y06091-740)

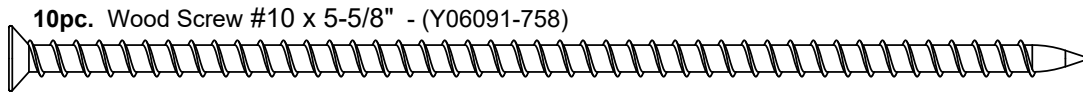

10pc. Wood Screw #10 x 5-5/8" - (Y06091-758)

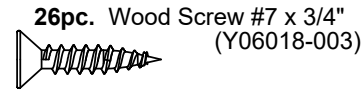

26pc. Wood Screw #7 x 3/4" (Y06018-003)

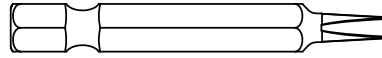

1pc. #2 x 2" Robertson Driver (Y00400-005)

1pc. - 1/8" Drill Bit (Y00400-002)

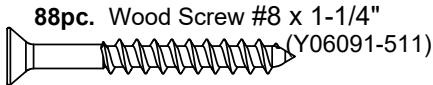

88pc. Wood Screw #8 x 1-1/4" (Y06091-511)

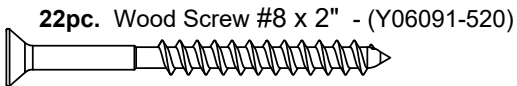

22pc. Wood Screw #8 x 2" - (Y06091-520)

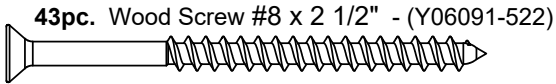

43pc. Wood Screw #8 x 2 1/2" - (Y06091-522)

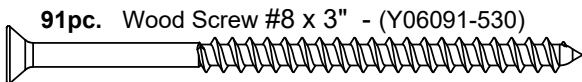

91pc. Wood Screw #8 x 3" - (Y06091-530)

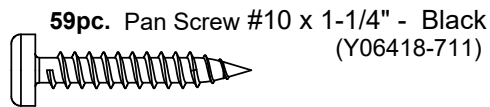

59pc. Pan Screw #10 x 1-1/4" - Black (Y06418-711)

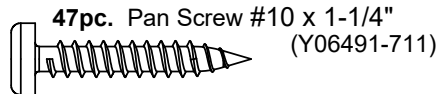

47pc. Pan Screw #10 x 1-1/4" (Y06491-711)

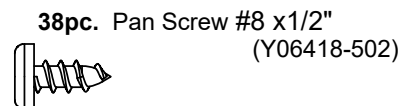

38pc. Pan Screw #8 x 1/2" (Y06418-502)

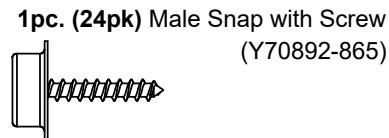

1pc. (24pk) Male Snap with Screw (Y70892-865)

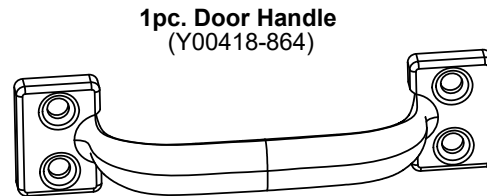

1pc. Door Handle (Y00418-864)

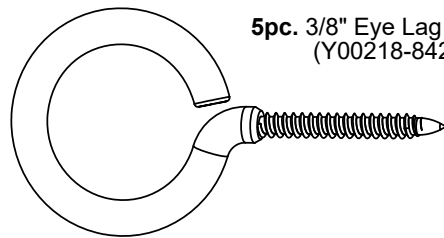

5pc. 3/8" Eye Lag -Black (Y00218-842)

1pc. Magnetic Catch with Plate (2pk) (Y70800-756)

2pc. Magnet (Y00400-756)

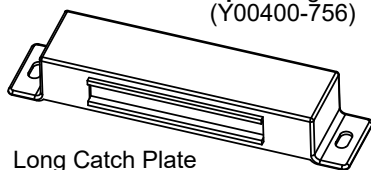

2pc. Long Catch Plate (Y00400-866)



1pc. Vent Mesh (Y20118-852)

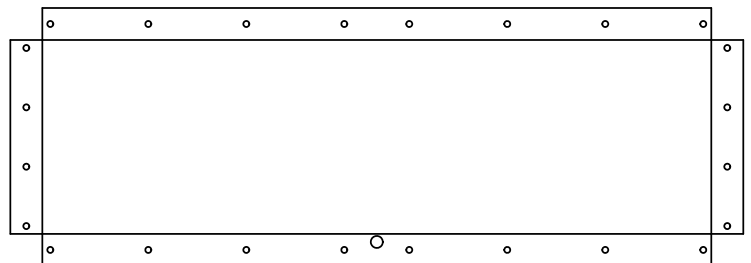

Step 1: Inventory Parts - Read This Before Starting Assembly

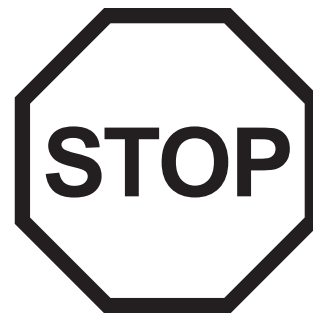
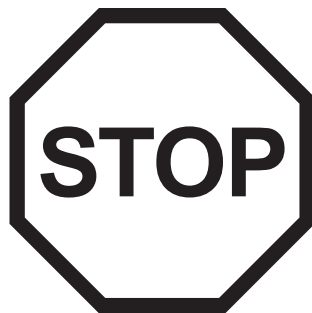
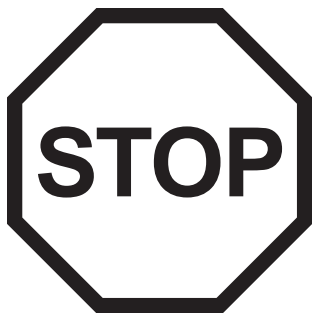

- A.** This is the time for you to inventory all your hardware, wood and accessories, referencing the parts identification sheets. This will assist you with your assembly.
- Each step indicates which bolts and/or screws you will need for assembly, as well as any flat washers, lock washers, t-nuts or lock nuts.
- B.** If there are any missing or damaged pieces or you need assistance with assembly please contact the consumer relations department directly. Call us before going back to the store.

1-888-509-4382

support@yardistrystructures.com

- C.** Read the assembly manual completely, paying special attention to ANSI warnings; notes; and safety/maintenance information on pages 1 - 4.
- Follow the instructions in order.
 - This structure is designed to be assembled and installed ideally by four people, DO NOT attempt to install alone.
 - Consider the slope of elevation where you plan to install the structure. Also, check for gas, telephone, other utilities or sprinkler line locations prior to excavating any holes.
- D.** Before you discard your cartons fill out the form below.
- The carton I.D. stamp is located on the end of each carton.
 - Please retain this information for future reference. You will need this information if you contact the Consumer Relations Department.

PRODUCT NUMBER: YM11945X

CARTON I.D. STAMP: _ _ _ _ _ (Box 1)

CARTON I.D. STAMP: _ _ _ _ _ (Box 2)

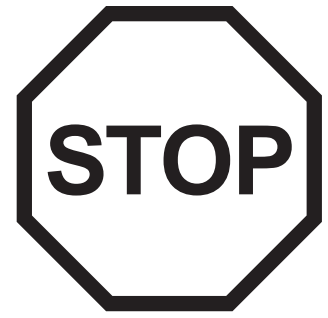
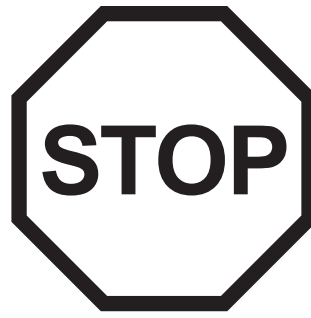
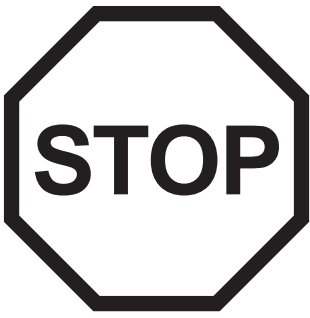

IMPORTANT! POLYCARBONATE INFORMATION

- Each polycarbonate panel has a UV coating on only ONE (1) side of the panel.
- To install properly so the UV coating is on the outside of the panel, the notch in the panel needs to be oriented to the bottom right-hand side of the assembly when on the outside facing the unit.

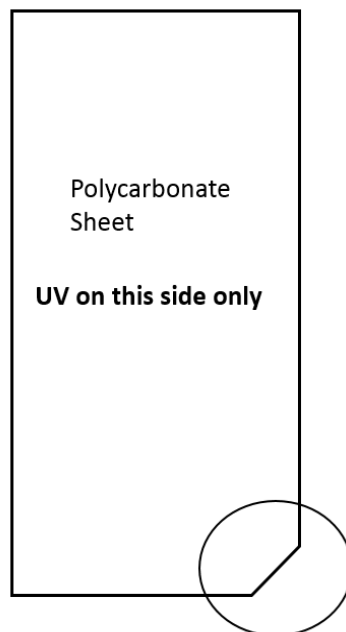

- Remove film immediately before installing tape to prevent damage to the panels.

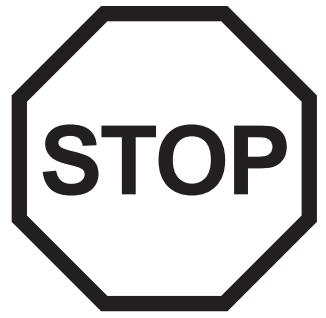
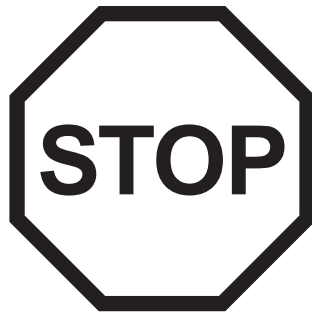
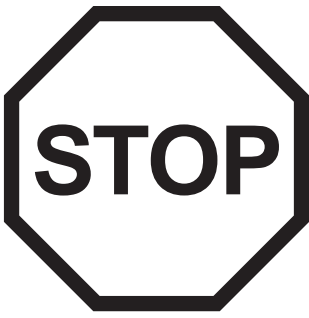

IMPORTANT! TAPE INFORMATION

- Two (2) different tapes are supplied. One for the top of the panels and one for the bottom.

Top



Bottom

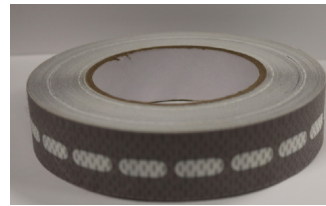

- Do NOT apply tape in direct sunlight.
- All surfaces must be clean and dry before installing the tape.
- Tape should be cut 2" (5.08 cm) longer than the width of the panel so it wraps around the corners and up the panel by 1" (2.54 cm) on each side.
- Remove the backing on the tape, centre it on the polycarbonate panel so it is equal on both sides. Fold the tape around the edges and rub gently to avoid damaging the tape.

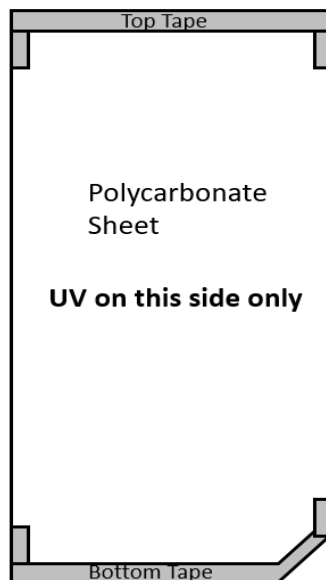

Step 2: Front Wall Assembly Part 1

A: At the bottom of one (1108) Left Post and one (1109) Right Post attach one (1119) Front Base with two #10 x 4" Wood Screws per post. Make sure grooves in posts are facing inwards and to the back. Posts are flush to the ends of (1119) Front Base. (F2.1, F2.2 and F2.3)

F2.1

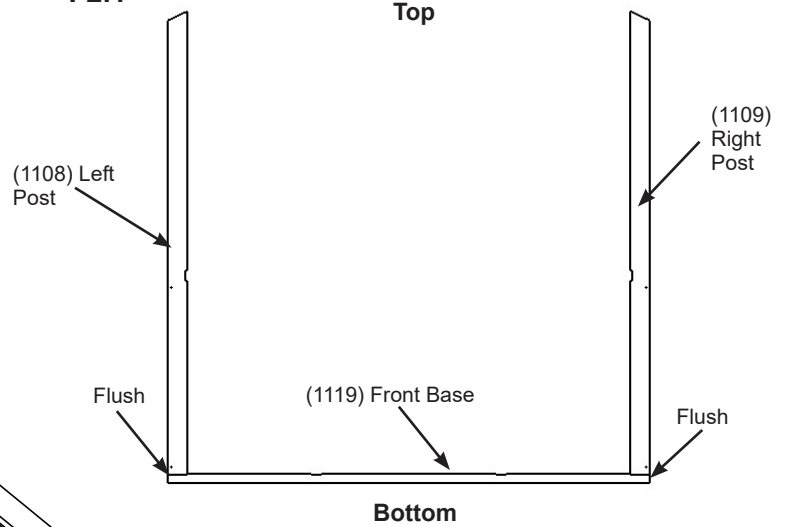

F2.2

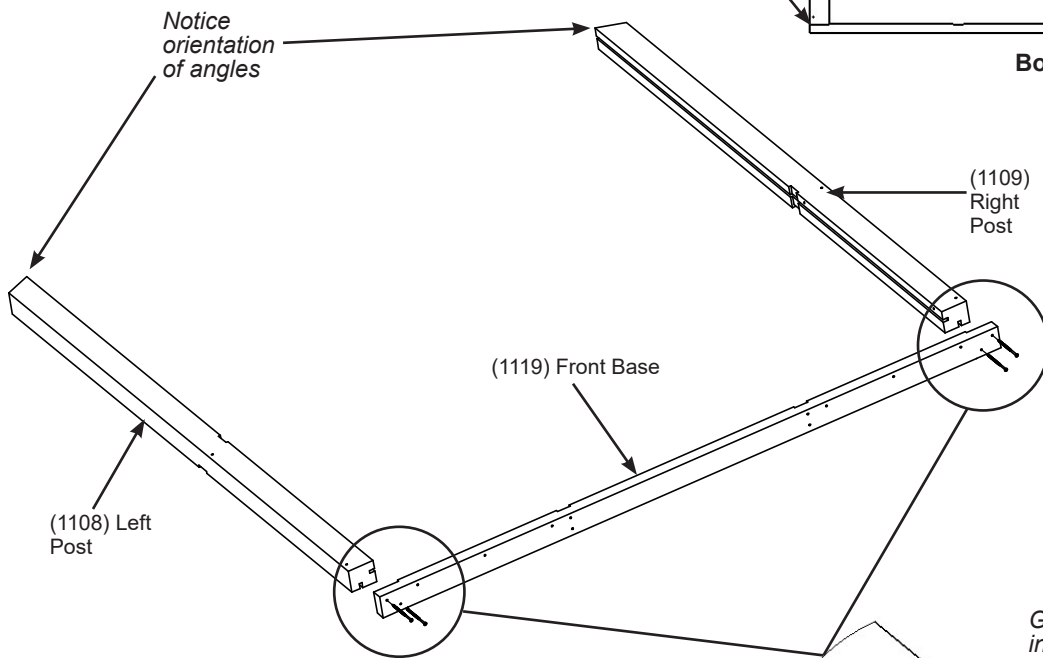

F2.3

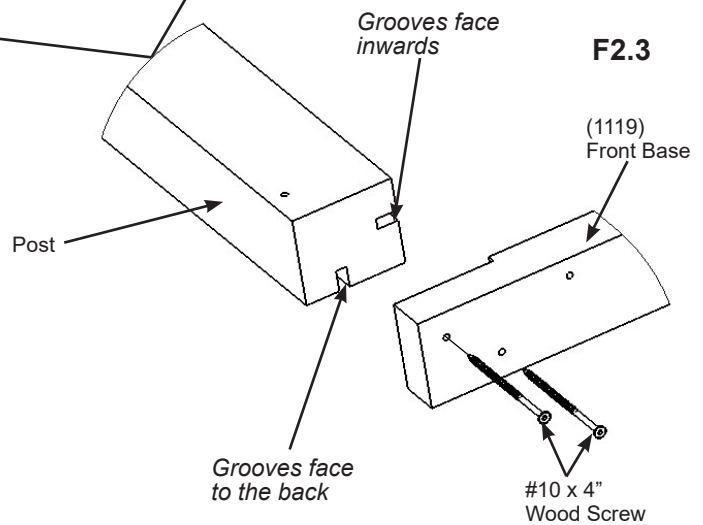

Wood Parts

- 1 x (1108) Left Post
- 1 x (1109) Right Post
- 1 x (1119) Front Base

Hardware

- 4 x #10 x 4" Wood Screw

Step 2: Front Wall Assembly Part 2

B: In the grooves of each post slide one (1147) FB Panel down so they rest tight to the top of the (1119) Front Base. (F2.4)

C: Place one (1111) Left Door Post and one (1112) Right Door Post tight to each (1147) FB Panel then attach to (1119) Front Base with two #8 x 3" Wood Screws per post. (F2.4 and F2.5)

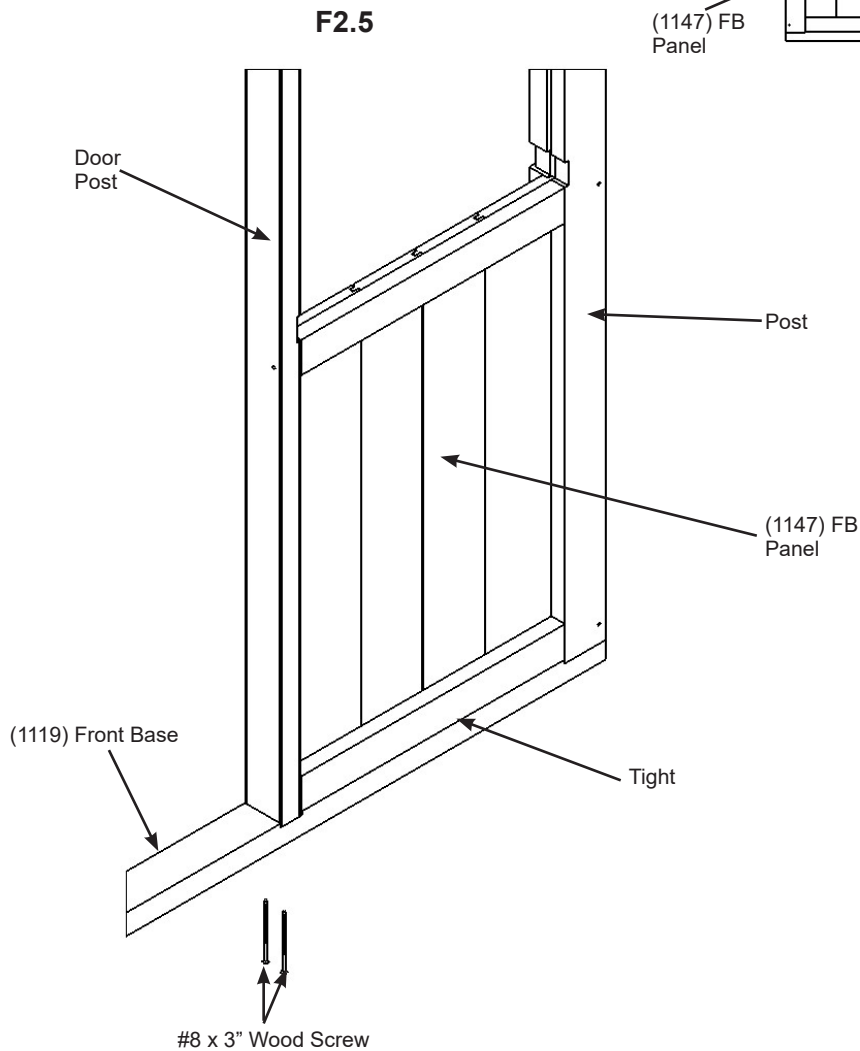
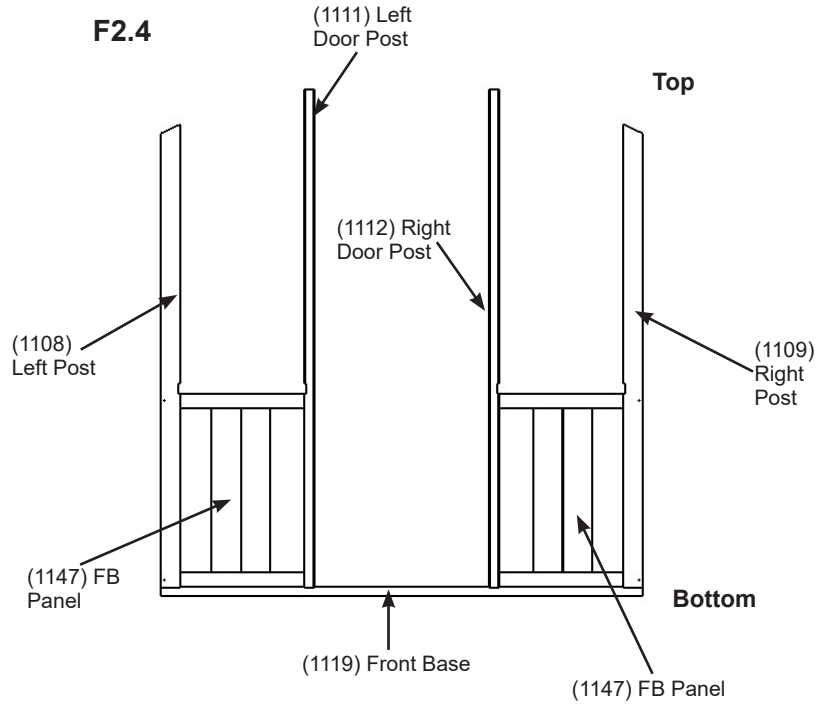

Wood Parts

- 1 x (1111) Left Door Post
- 1 x (1112) Right Door Post
- 2 x (1147) FB Panel

Hardware

- 4 x #8 x 3" Wood Screw

Step 2: Front Wall Assembly Part 3

D: Attach (1111) Left Door Post and (1112) Right Door Post to (1147) FB Panel with one #8 x 3" Wood Screw per post. (F2.6 and F2.7)

E: Attach (1119) Front Base to (1147) FB Panels with three #8 x 3" Wood Screws per panel. (F2.6 and F2.8)

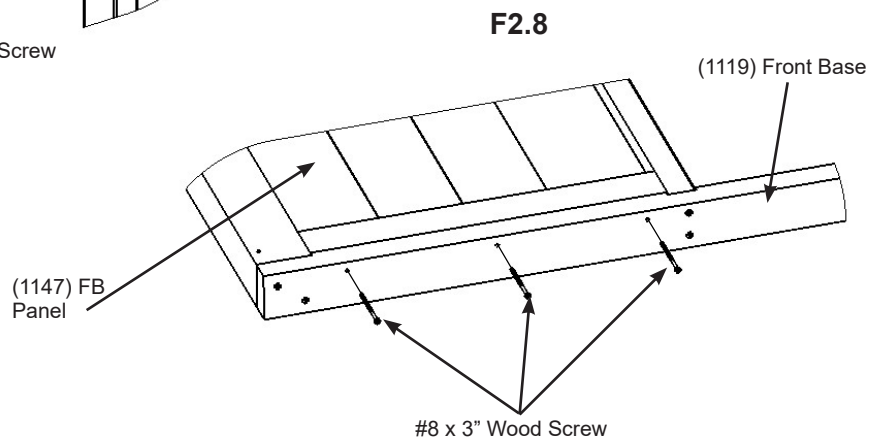
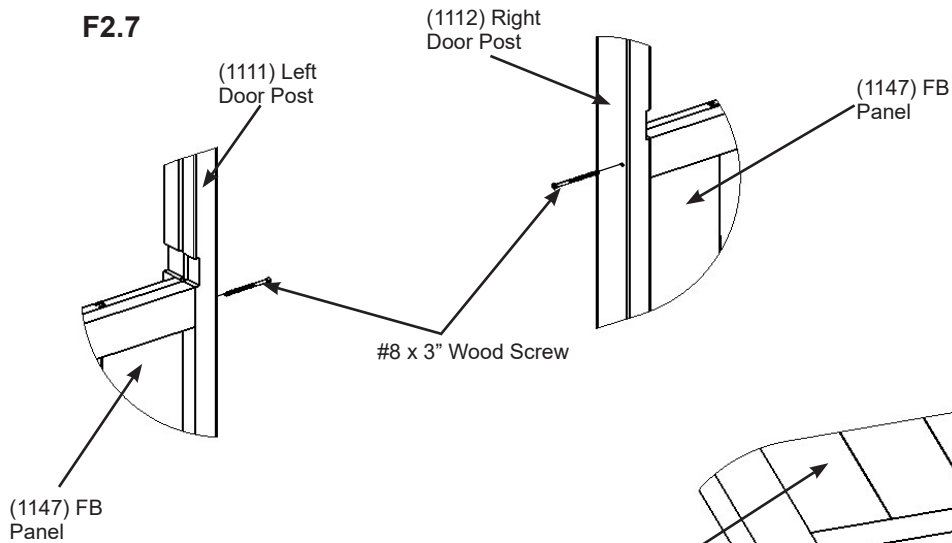
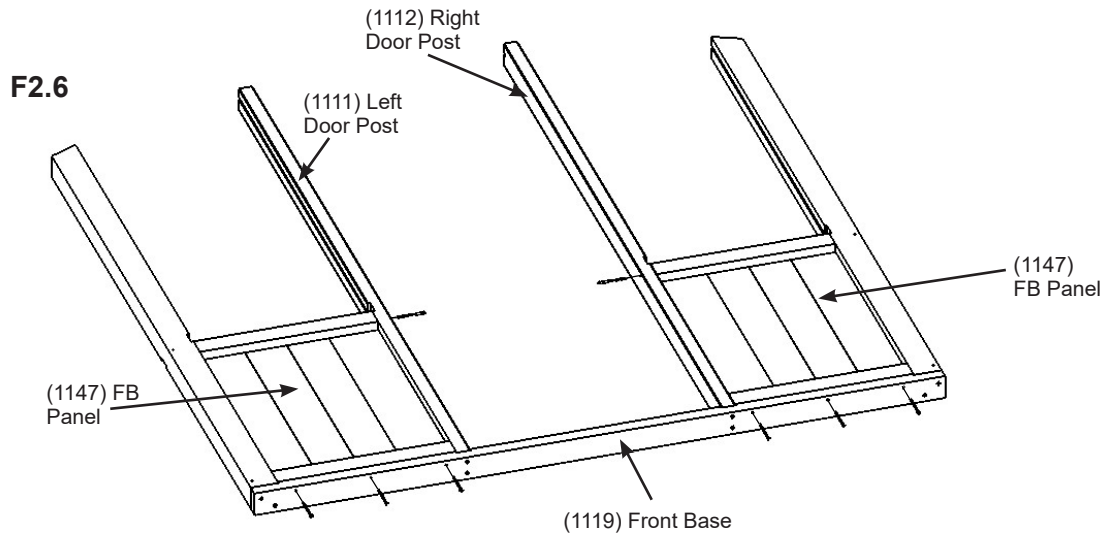

Hardware

8 x #8 x 3" Wood Screw

Step 2: Front Wall Assembly Part 4

F: Attach (1108) Left Post and (1109) Right Post to top and bottom of (1147) FB Panel with two #10 x 4" Wood Screws per post. (F2.9)

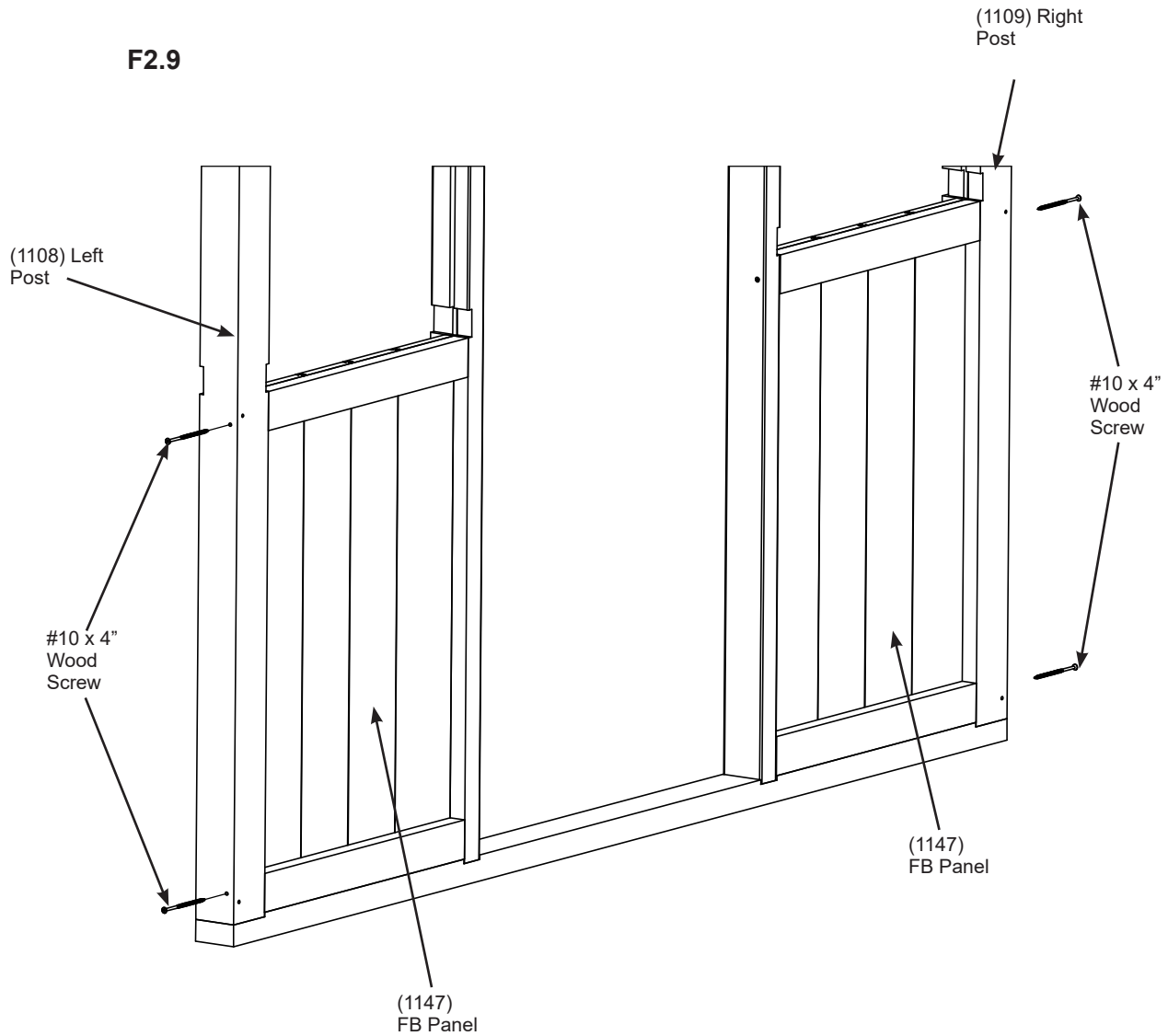

Hardware

4 x #10 x 4" Wood Screw

Step 2: Front Wall Assembly Part 5

G: Place one (1105) Front Wall Sill on top of each (1147) FB Panel. Use one (1188) Guide Spacer in the grooves of each post and (1105) Front Wall Sill to line up Posts with Door Posts. Attach (1105) Front Wall Sills to (1147) FB Panels with two #8 x 3" Wood Screws per panel. Remove (1188) Guide Spacers. (F2.10, F2.11 and F2.12)

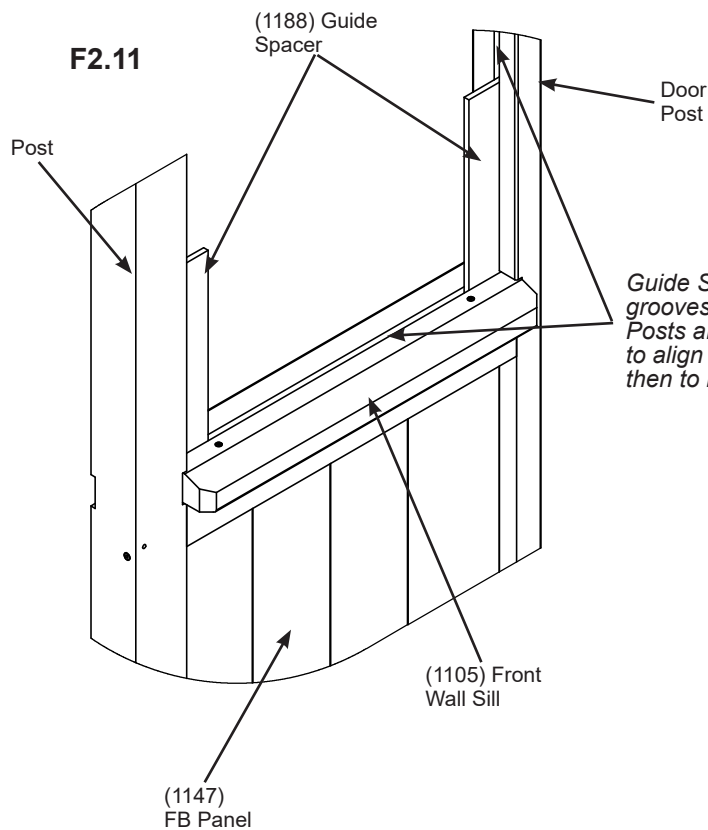
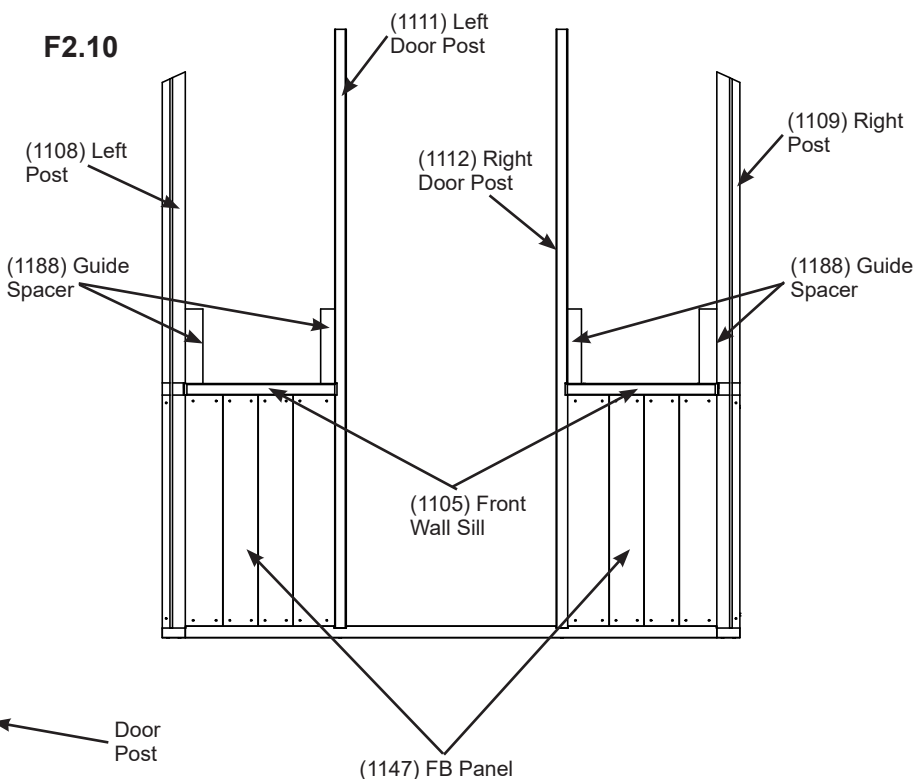

Guide Spacers to sit in grooves of Posts, Door Posts and Front Wall Sill to align posts correctly, then to be removed.

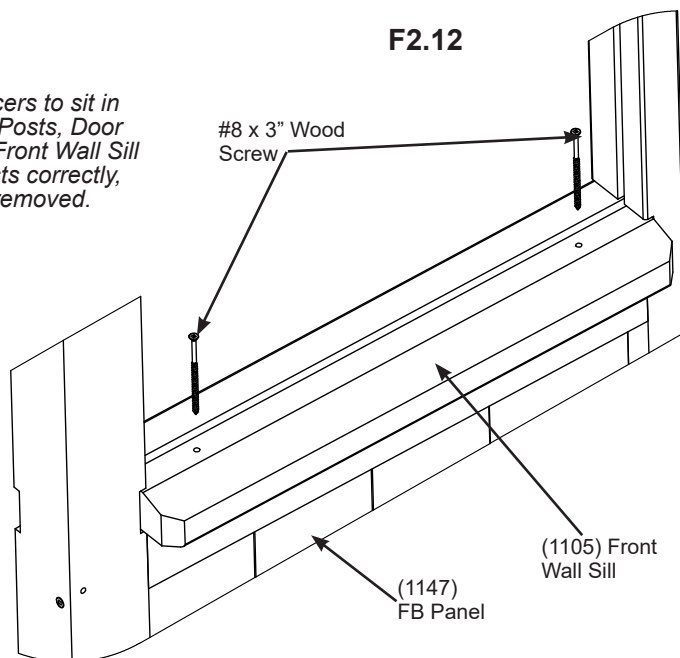

Wood Parts

2 x (1105) Front Wall Sill

Hardware

4 x #8 x 3" Wood Screw

Step 2: Front Wall Assembly Part 6

Remove film from both sides of Left FB Side Panel and Right FB Side Panel.

H: Refer to pages 16 and 17 and apply top and bottom tape to Left FB Side Panel and Right FB Side Panel.

I: In the grooves of Posts and Door Posts slide Left FB Side Panel and Right FB Side Panel down so they rest in the grooves of (1105) Front Wall Sill. Make sure the notch at the bottom is always on the right side of the panel. The UV coated side must be to the outside of the frame. (F2.13 and F2.14)

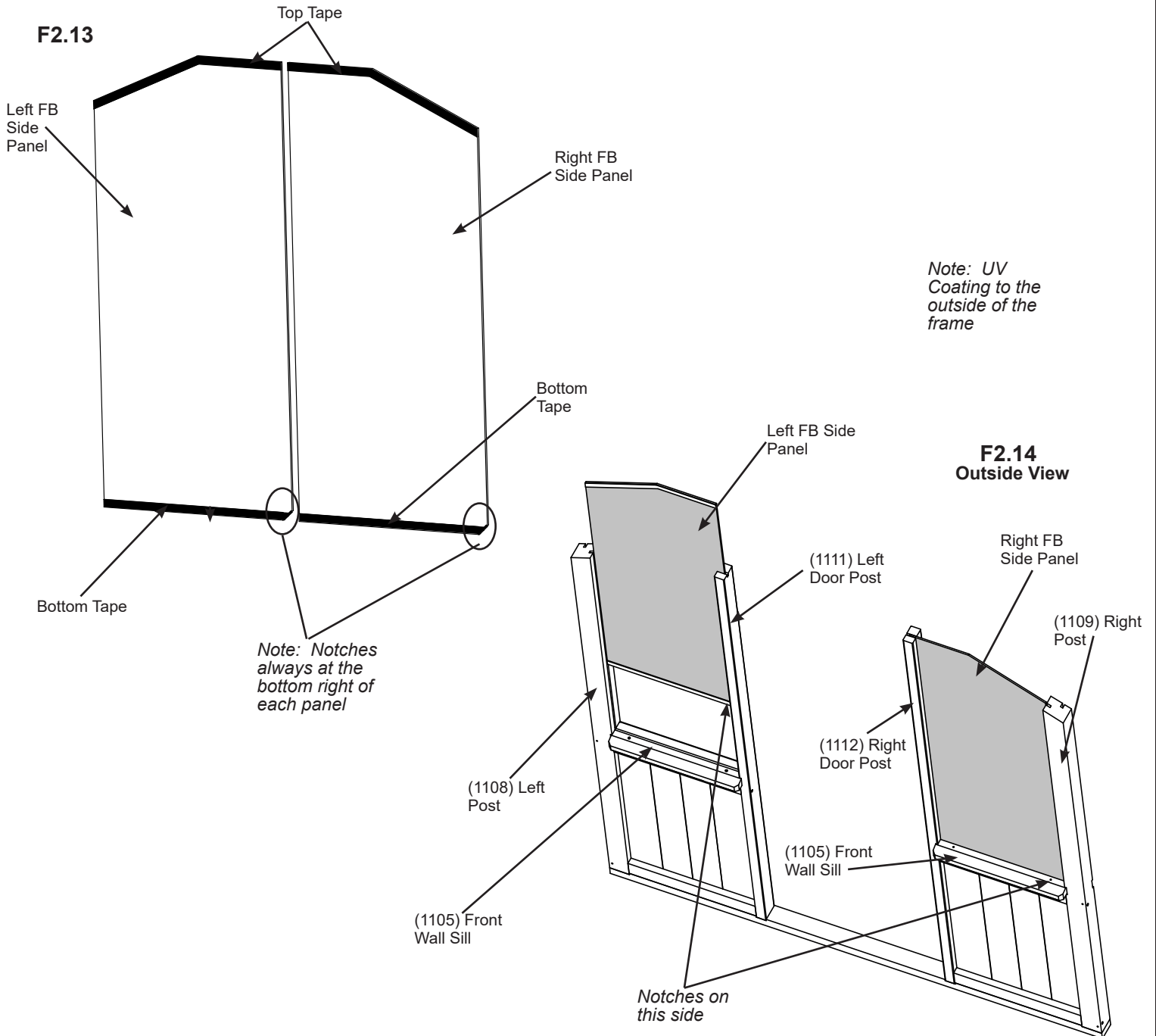

Components

- 1 x Left FB Side Panel
- 1 x Right FB Side Panel
- Top Tape
- Bottom Tape

Step 2: Front Wall Assembly Part 7

J: Place (1143) Front Gable Beam on top of (1111) Left Door Post and (1112) Right Door Post so notches on the bottom fit over the posts then attach with two #10 x 4" Wood Screws per post. (F2.15 and F2.16)

F2.15

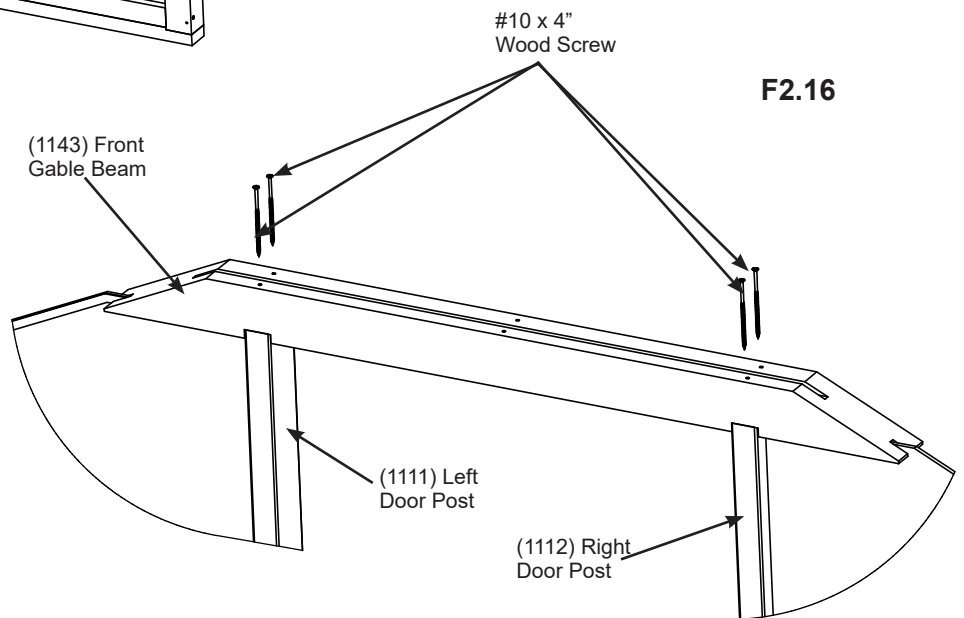
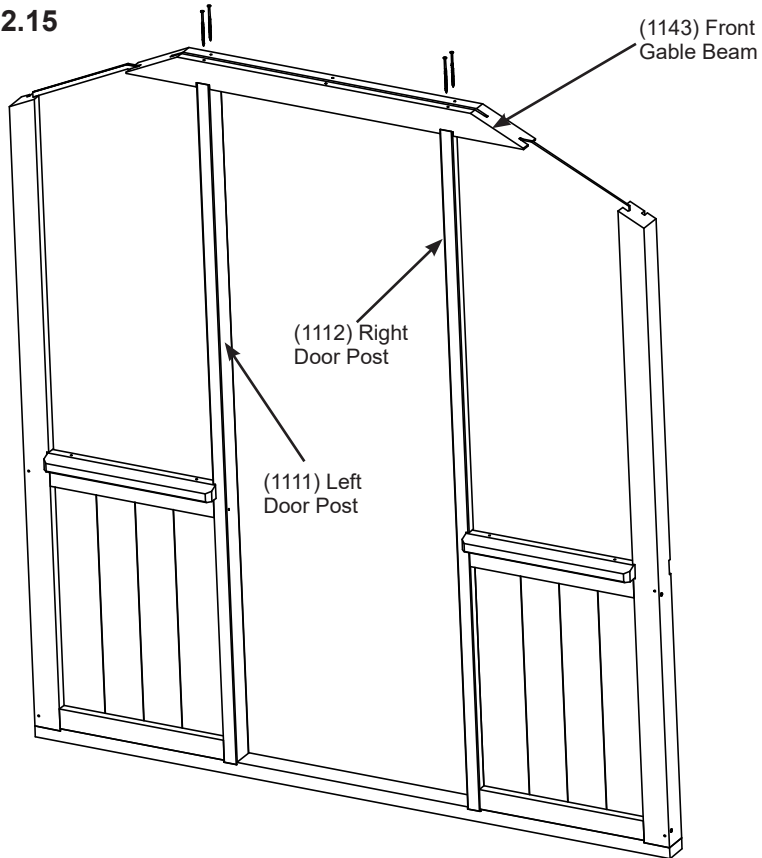

Wood Parts

1 x (1143) Front Gable Beam

Hardware

4 x #10 x 4" Wood Screw

Step 2: Front Wall Assembly Part 8

K: Place one (1121) Upright Inside and one (1122) Upright Outside centred on the top of (1143) Front Gable Beam. Use one (1188) Guide Spacer in the grooves of (1143) Front Gable Beam for proper spacing of Uprights. Attach Beam to Uprights with one #10 x 4" Wood Screw per upright. Remove (1188) Guide Spacer. (F2.17, F2.18 and F2.19)

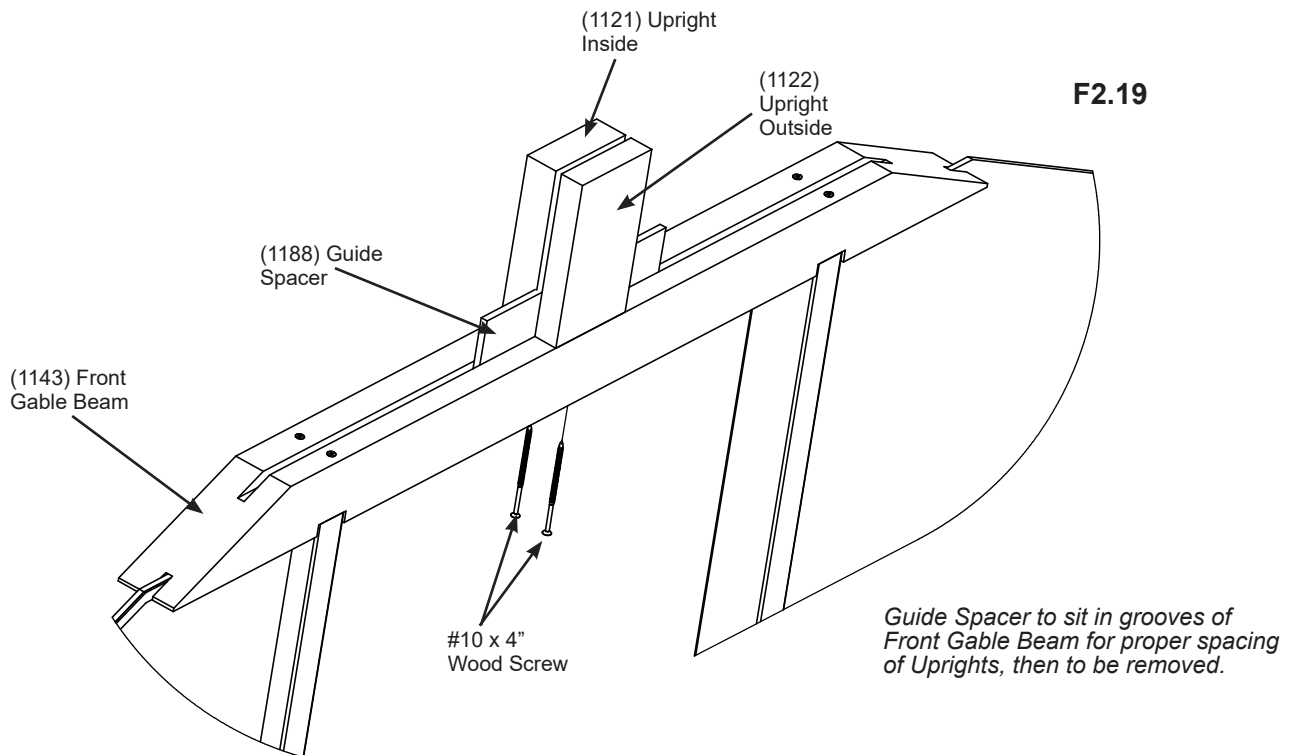
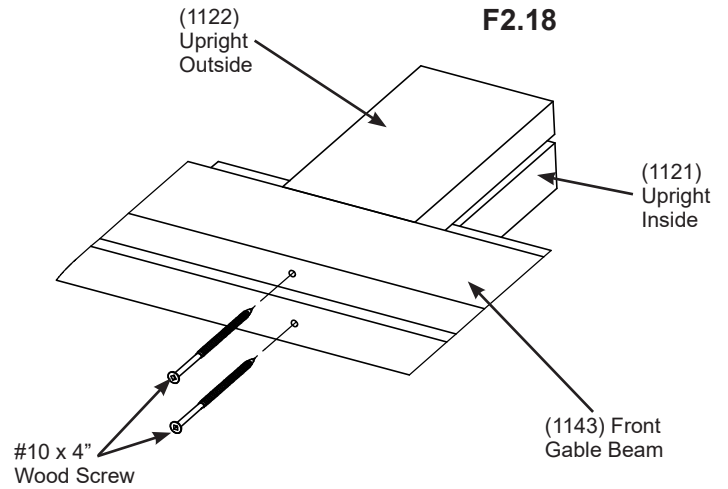
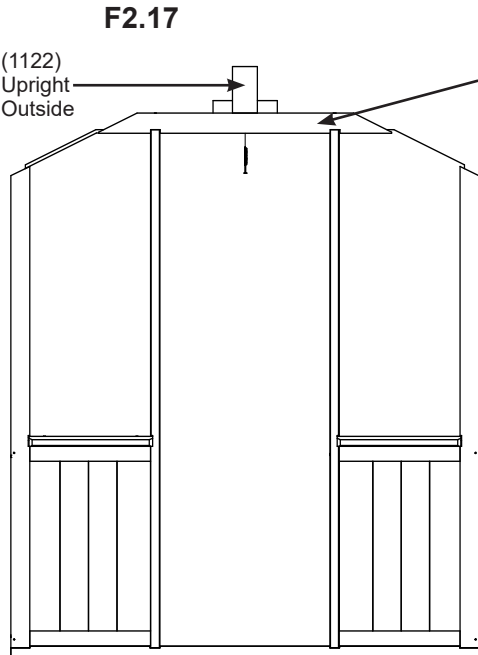

Wood Parts

- 1 x (1121) Upright Inside
- 1 x (1122) Upright Outside

Hardware

- 2 x #10 x 4" Wood Screw

Step 2: Front Wall Assembly Part 9

Remove film from both sides of Gable Panel.

L: Refer to pages 16 and 17 and apply top and bottom tape to Gable Panel.

M: Slide Gable Panel down into the grooves of (1143) Front Gable Beam, in between (1121) Upright Inside and (1122) Upright Outside. Make sure the notch at the bottom is on the right side of the panel. The UV coated side must be to the outside of the frame. (F2.20, F2.21 and F2.22)

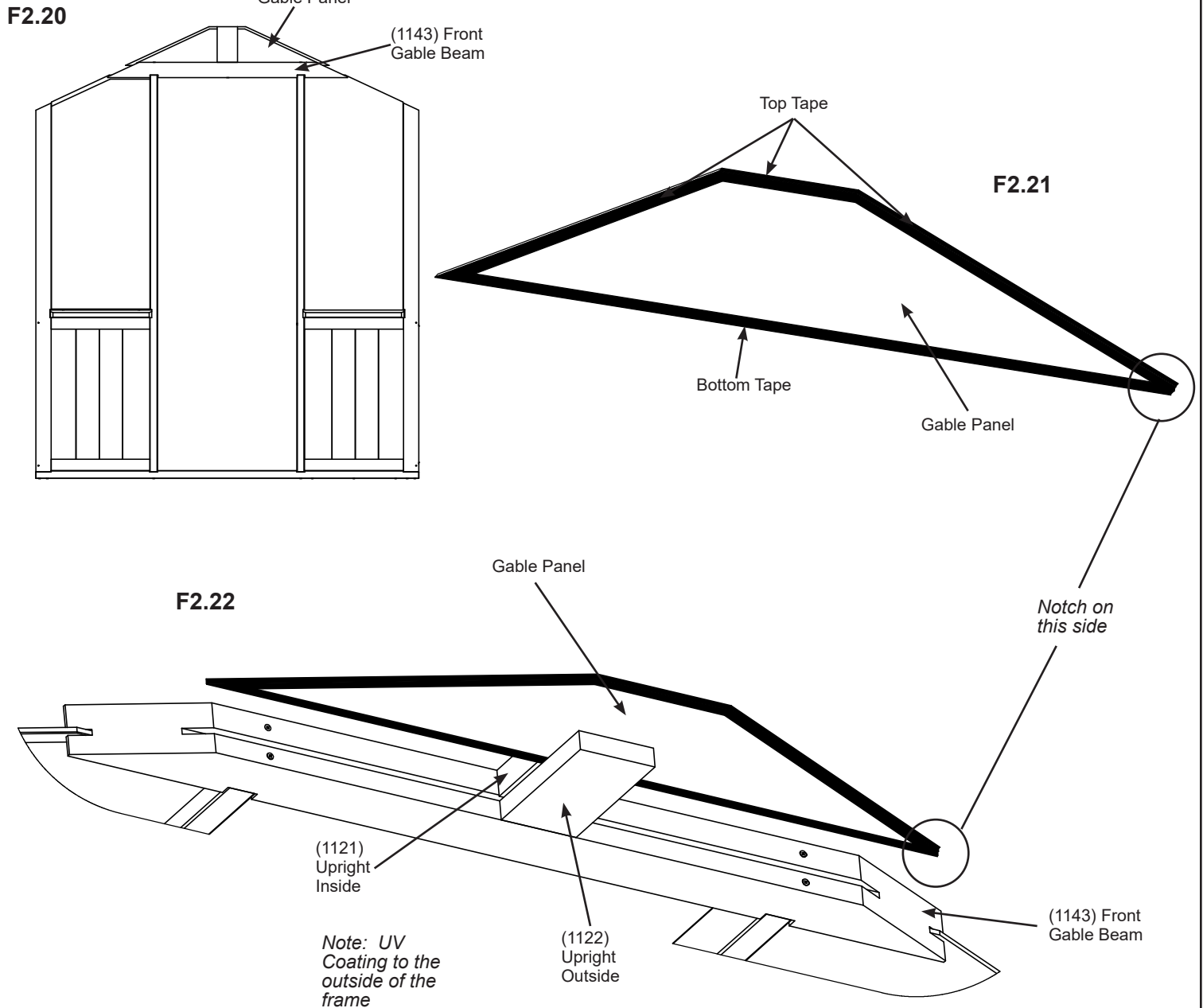

Components

- 1 x Gable Panel
- Top Tape
- Bottom Tape

Step 2: Front Wall Assembly

Part 10



N: Place one (1115) Right Roof Rafter and one (1116) Left Roof Rafter on each side of the frame so the ends overhang (1108) Left Post and (1109) Right Post by 1-1/2" (3.81 cm). They will sit on the uprights. Make sure grooves in rafters face inwards. Place one (1184) Peak Spacer between (1115) Right Roof Rafter and (1116) Left Roof Rafter so the detail is on the outside of the assembly. Attach rafters to posts with one #10 x 5-5/8" Wood Screw per post and to (1143) Front Gable Beam with one #10 x 4" Wood Screw per rafter. The distance from outside of the Left and Right Post to the inside of the Left and Right Door Post should be 23-7/8" (60.6 cm). (F2.23, F2.24 and F2.25)

O: Attach each rafter to Peak Spacer with one #10 x 4" Wood Screw per rafter. Attach (1184) Peak Spacer to rafters with two #8 x 2" Wood Screws. (F2.24 and F2.25)

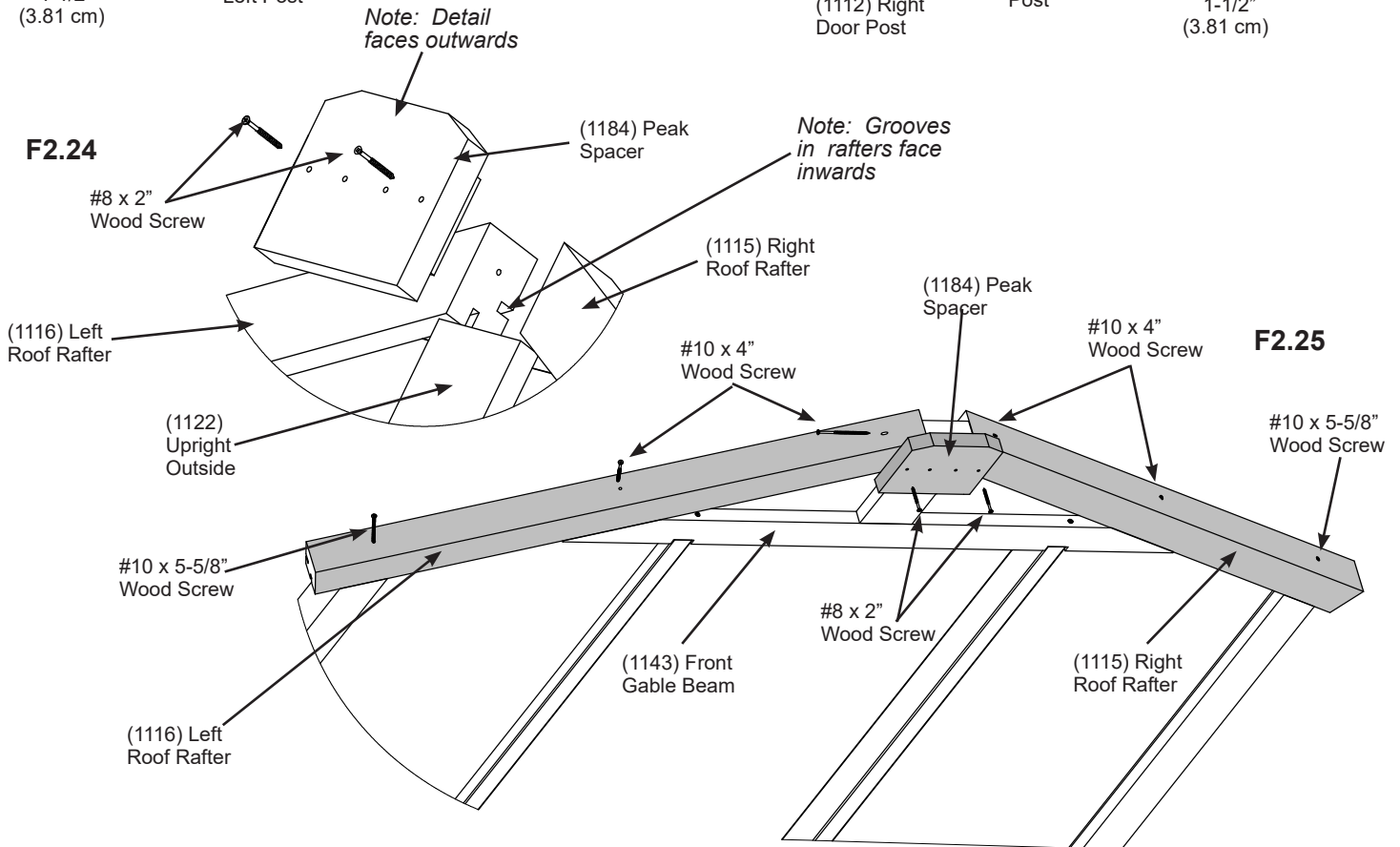
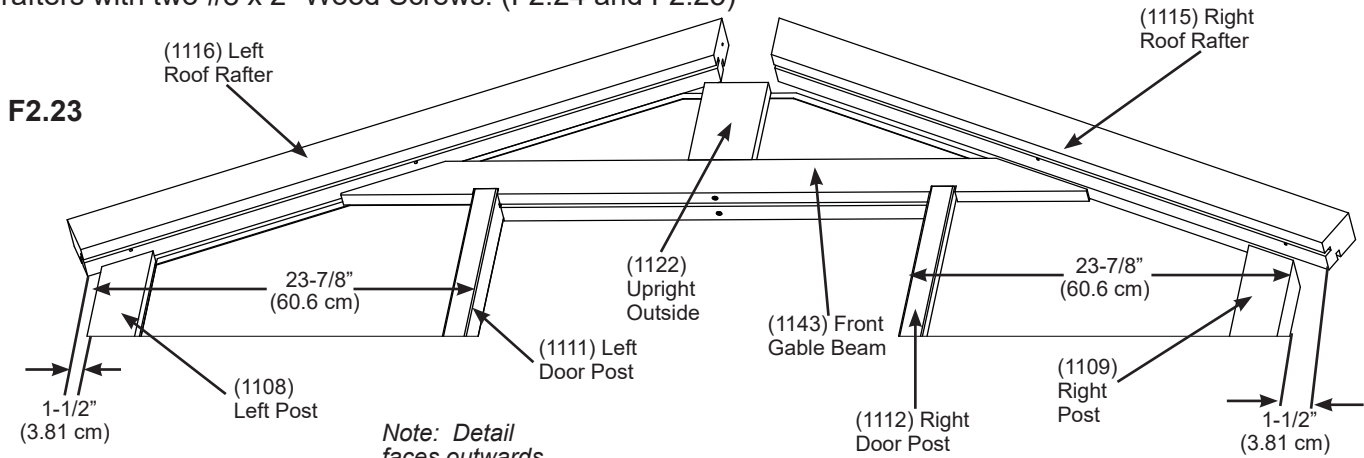

Wood Parts

- 1 x (1115) Right Roof Rafter
- 1 x (1116) Left Roof Rafter
- 1 x (1184) Peak Spacer

Hardware

- 2 x #10 x 5-5/8" Wood Screw
- 4 x #10 x 4" Wood Screw
- 2 x #8 x 2" Wood Screw

Step 3: Back Wall Assembly Part 1

A: At the bottom of one (1108) Left Post and one (1109) Right Post attach one (1120) Back Base with two #10 x 4" Wood Screws per post. Make sure grooves in posts are facing inwards and to the back. Posts are flush to the ends of (1120) Back Base. (F3.1, F3.2 and F3.3)

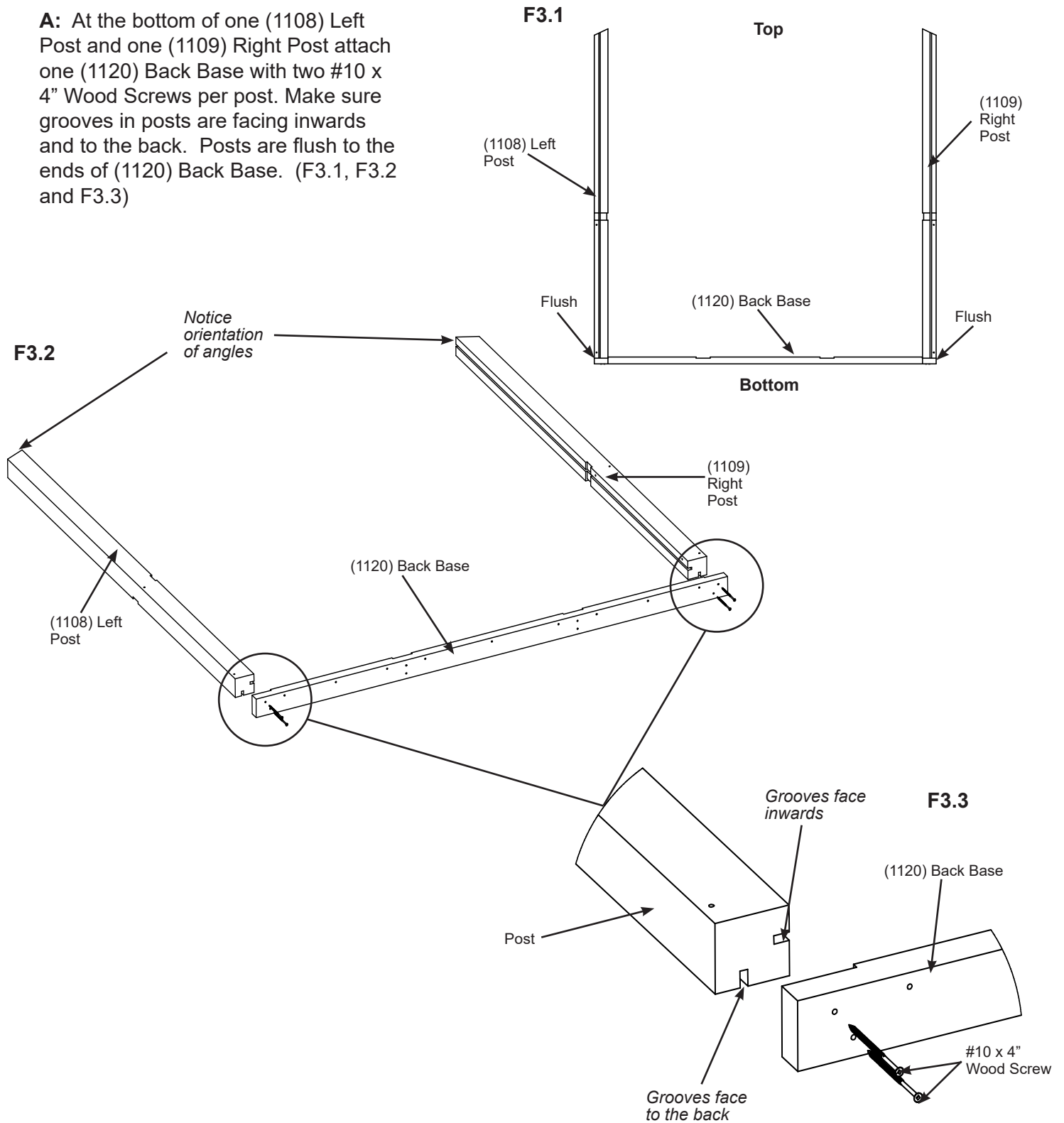

Wood Parts

- 1 x (1108) Left Post
- 1 x (1109) Right Post
- 1 x (1120) Back Base

Hardware

- 4 x #10 x 4" Wood Screw

Step 3: Back Wall Assembly Part 2

B: In the grooves of each post slide one (1147) FB Panel down so they rest tight to the top of the (1120) Back Base. (F3.4)

C: Place one (1113) Back Post tight to each (1147) FB Panel then attach to (1120) Back Base with two #10 x 4" Wood Screws per post. (F3.4 and F3.5)

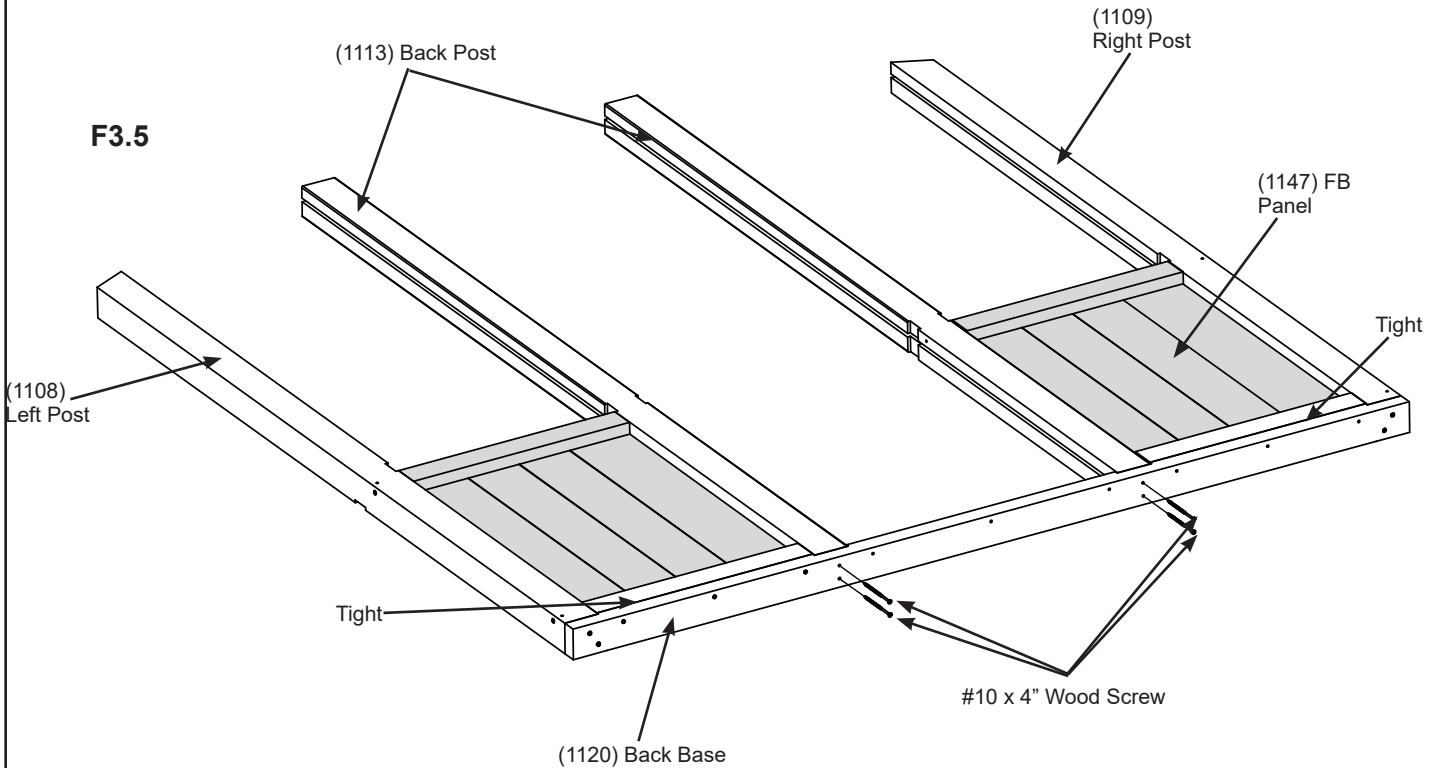
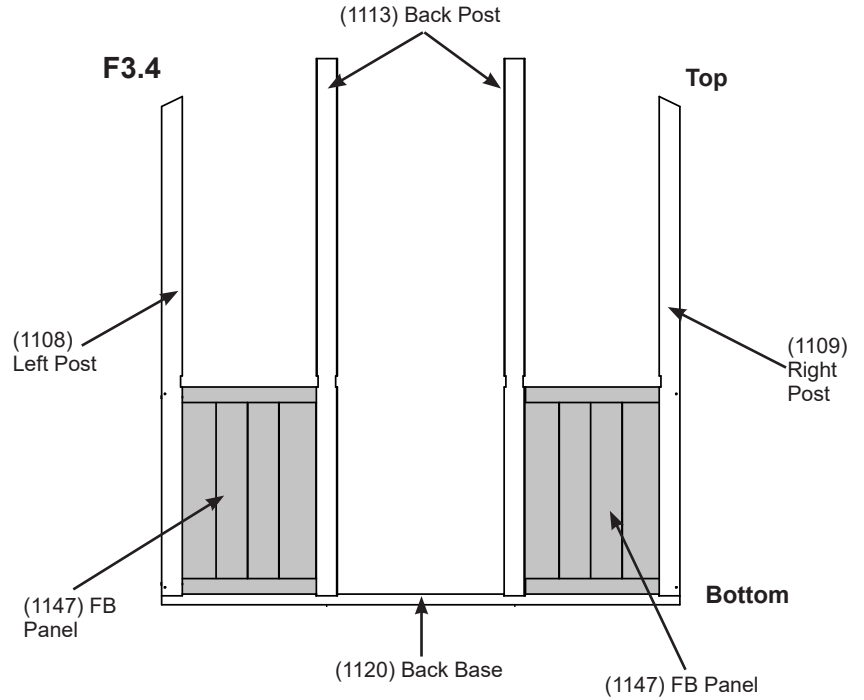

Wood Parts

- 2 x (1113) Back Post
- 2 x (1147) FB Panel

Hardware

- 4 x #10 x 4" Wood Screw

Step 3: Back Wall Assembly Part 3

D: Attach (1108) Left Post, (1109) Right Post to each (1147) FB Panel with two #10 x 4" Wood Screws per post and each (1113) Back Post to each (1147) FB Panel with one #10 x 4" Wood Screw per post. (F3.6 and F3.7)

E: Attach (1120) Back Base to (1147) FB Panels with three #8 x 3" Wood Screws per panel. (F3.6 and F3.7)

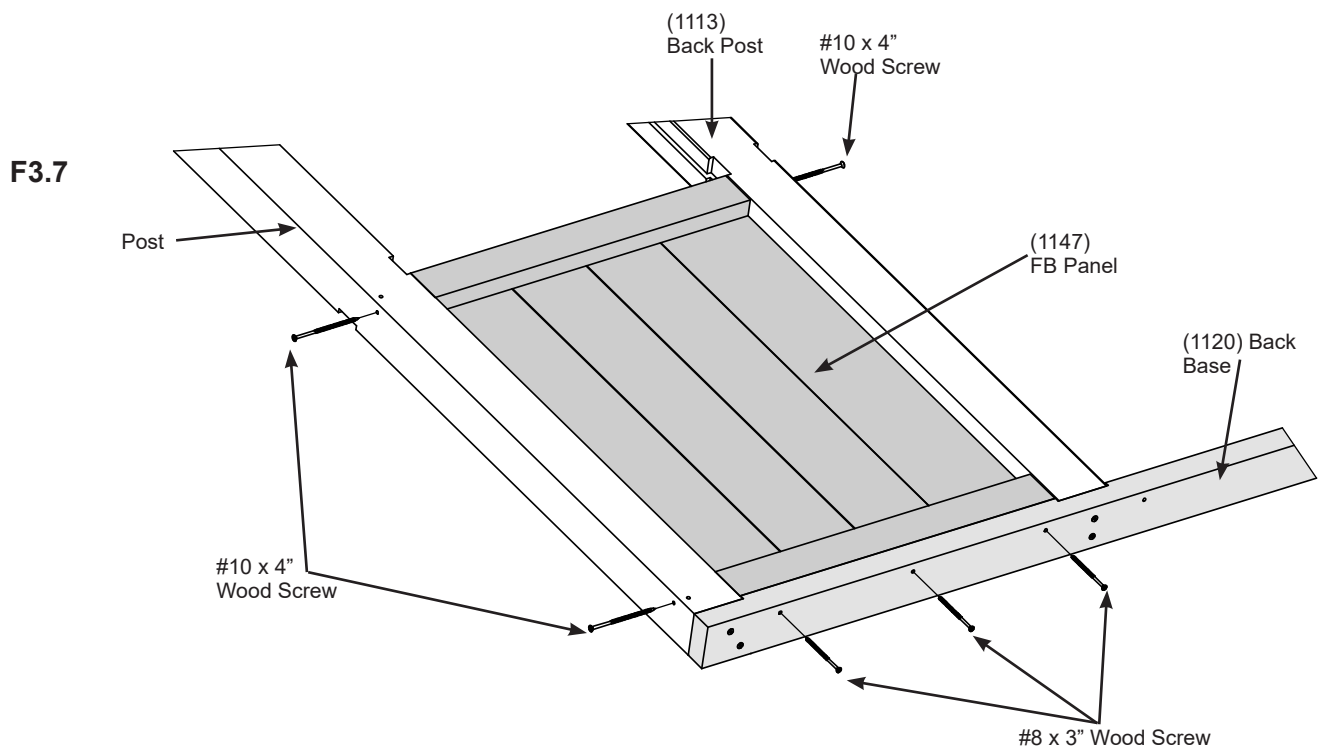
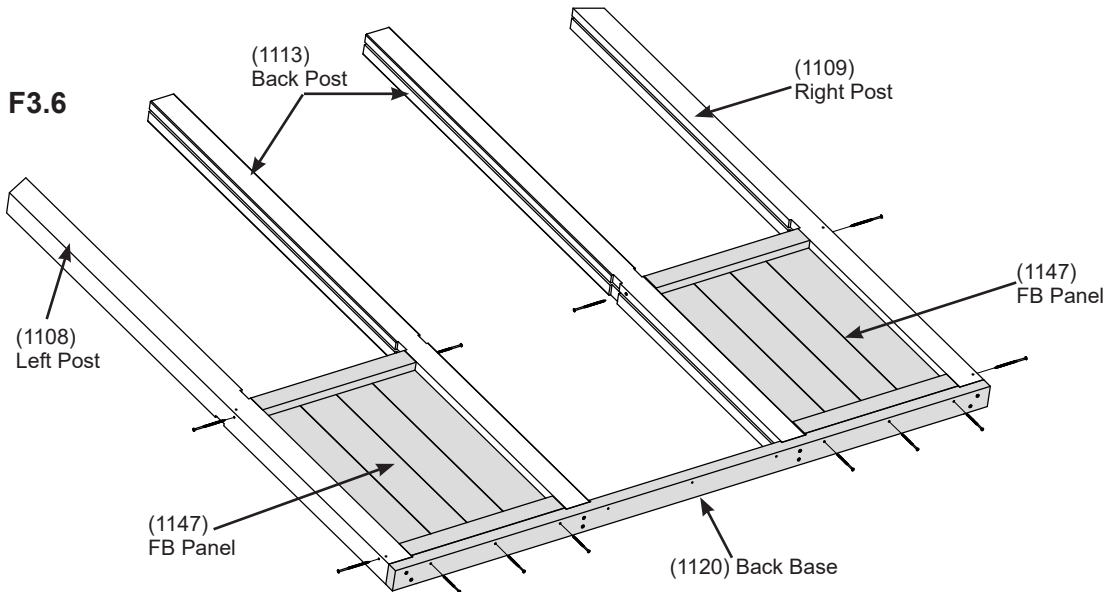

Hardware

6 x #10 x 4" Wood Screw

6 x #8 x 3" Wood Screw

Step 3: Back Wall Assembly Part 4

F: In the grooves of each (1113) Back Post slide one (1155) Vent Wall Panel down so it rests tight to the top of the (1120) Back Base. Vent should be closer to the (1120) Back Base. (F3.8 and F3.9)

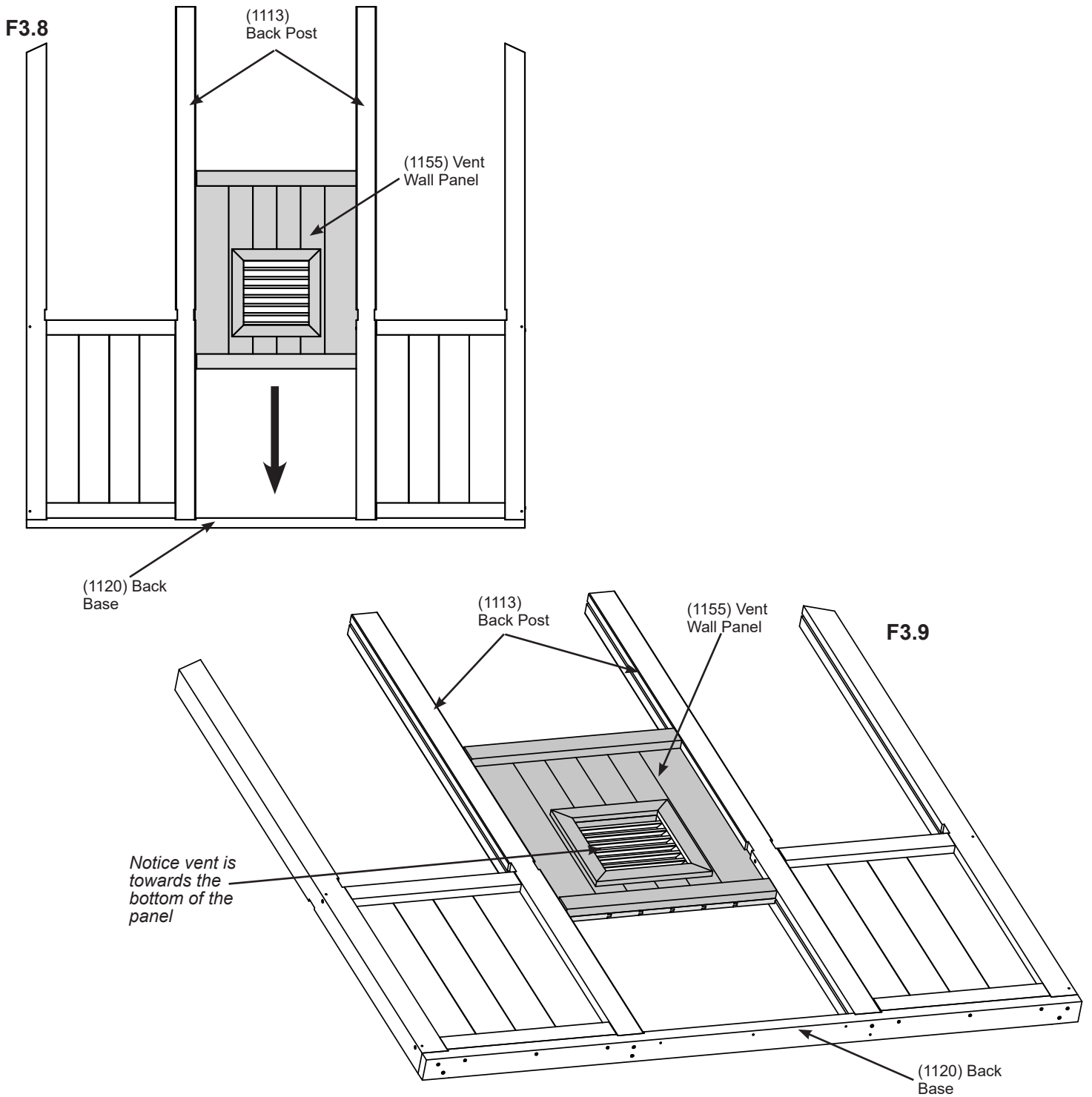

Wood Parts

1 x (1155) Vent Wall Panel

Step 3: Back Wall Assembly Part 5

G: Attach (1120) Back Base to (1155) Vent Wall Panel with three #8 x 3" Wood Screws. (F3.10 and F3.12)

H: Place one (1106) Back Wall Sill on top of (1155) Vent Wall Panel and each (1147) FB Panel so the notches fit around each (1113) Back Post. Use (1188) Guide Spacer in the grooves of each post and (1106) Back Wall Sill to line up Posts. Attach (1106) Back Wall Sills to (1147) FB Panels and (1155) Vent Wall Panel with two #8 x 3" Wood Screws per panel. Remove (1188) Guide Spacers. (F3.10, F3.11 and F3.13)

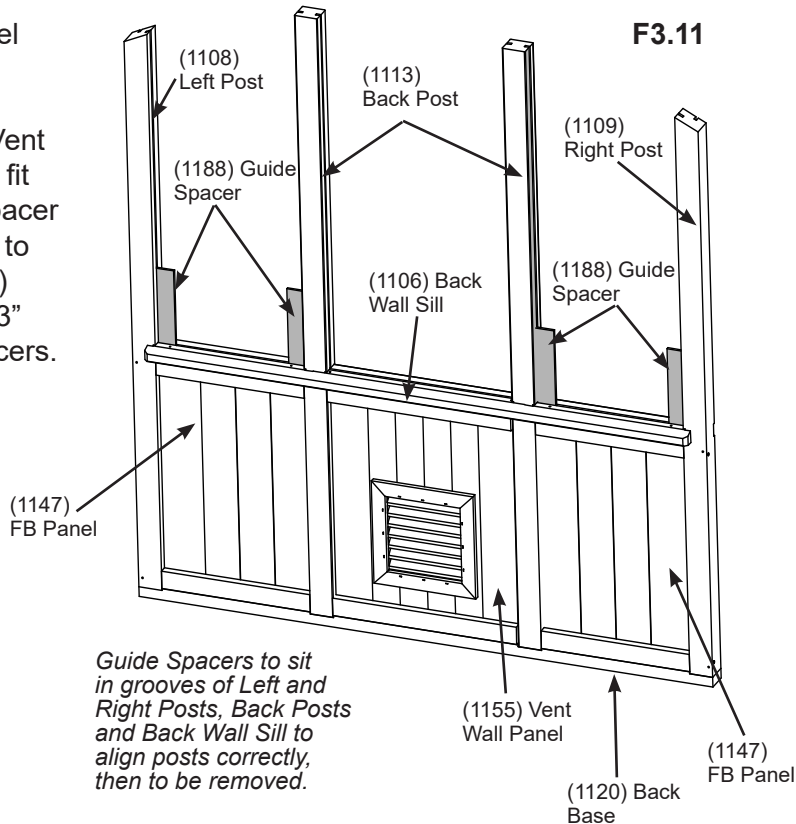
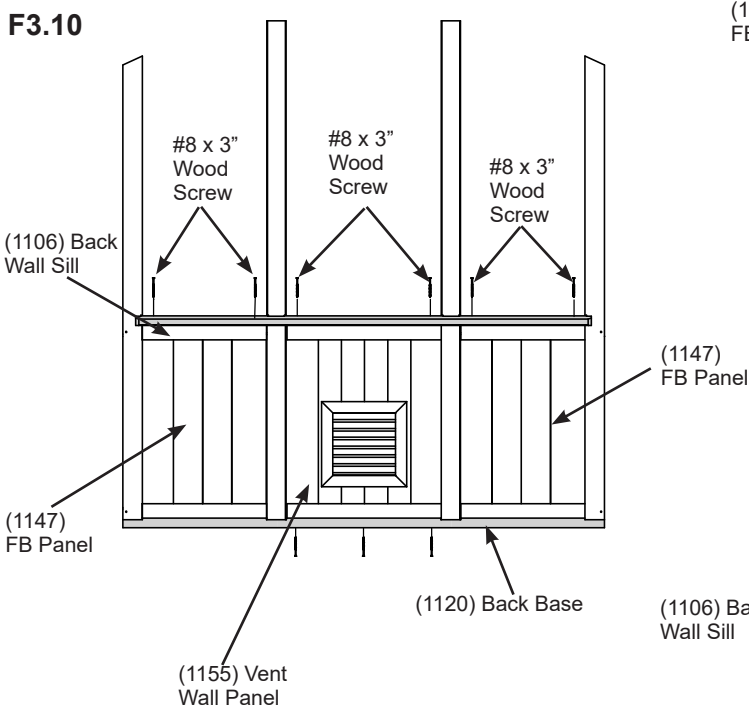

Guide Spacers to sit in grooves of Left and Right Posts, Back Posts and Back Wall Sill to align posts correctly, then to be removed.

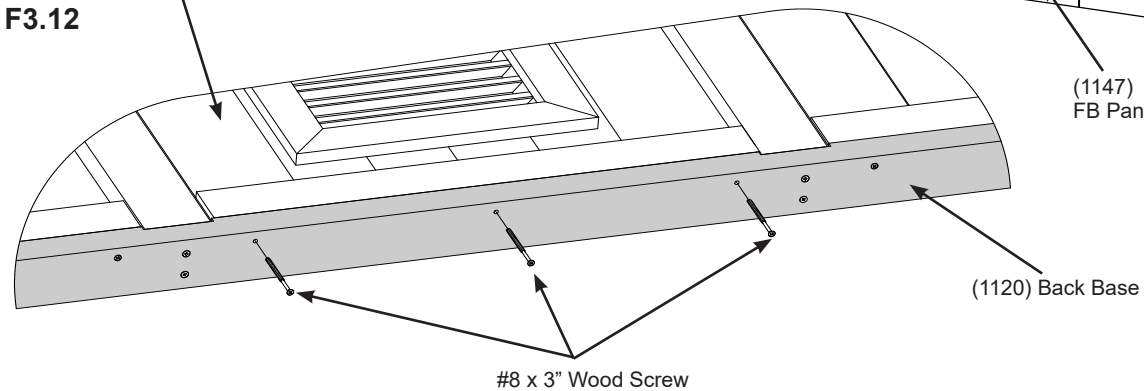
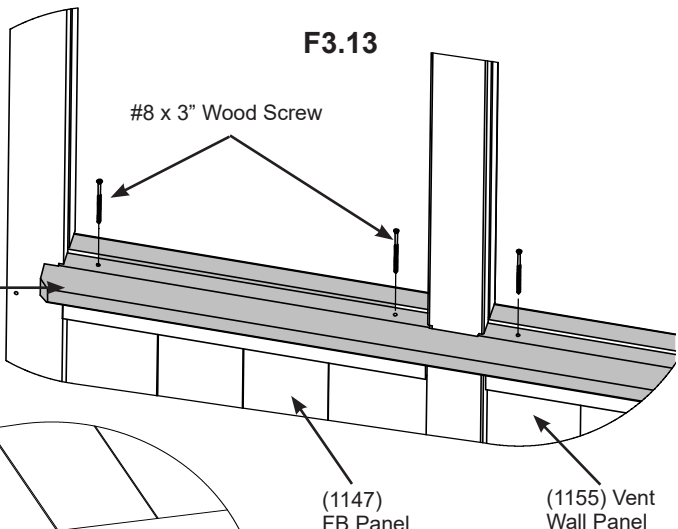

Wood Parts

1 x (1106) Back Wall Sill

Hardware

9 x #8 x 3" Wood Screw

Step 3: Back Wall Assembly Part 6

Remove film from both sides of Left FB Side Panel, Right FB Side Panel and Back Centre Panel.

I: Refer to pages 16 and 17 and apply top and bottom tape to Left FB Side Panel, Right FB Side Panel and Back Centre Panel.

J: In the grooves of Left and Right Posts and Back Post slide Left FB Side Panel and Right FB Side Panel down to fit in the grooves of (1106) Back Wall Sill. In the grooves of Back Posts slide Back Centre Panel down so it fits in the grooves of (1106) Back Wall Sill. Make sure the notch at the bottom is always on the right side of the panel. The UV coated side must be to the outside of the frame. (F3.14 and F3.15)

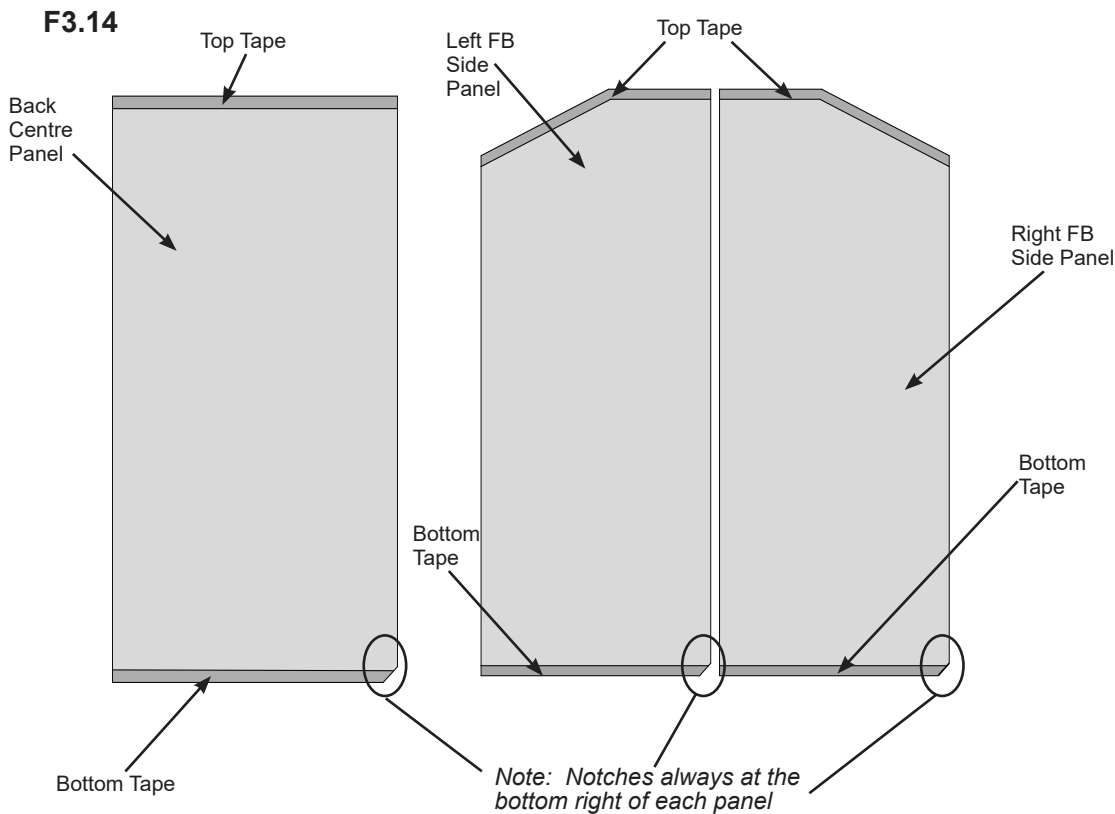
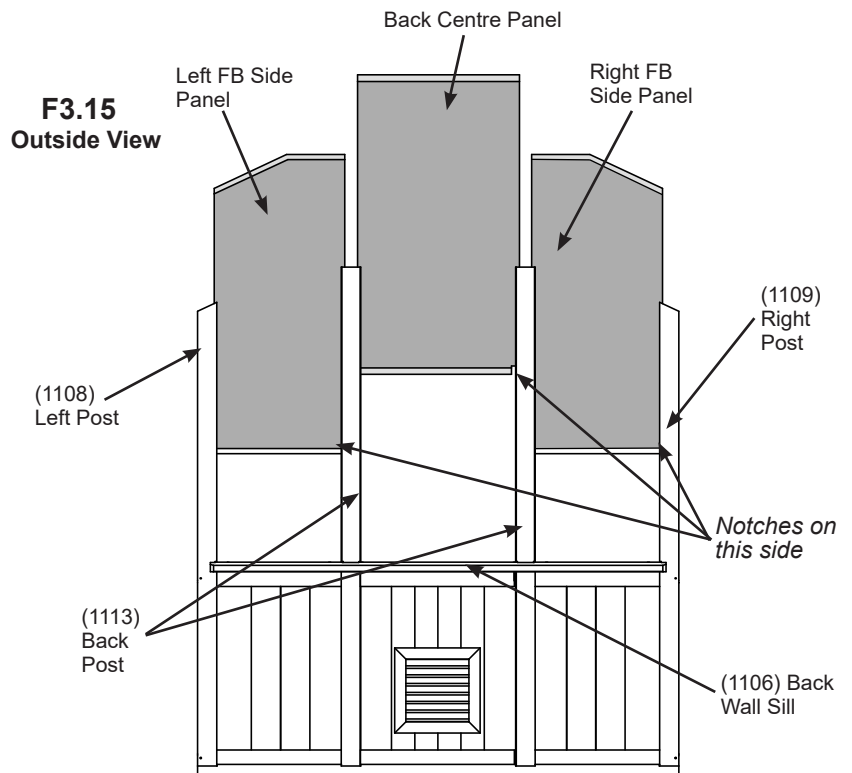

Note: UV Coating to the outside of the frame

Components

- | | |
|-------------------------|-------------|
| 1 x Left FB Side Panel | Top Tape |
| 1 x Right FB Side Panel | Bottom Tape |
| 1 x Back Centre Panel | |

Step 3: Back Wall Assembly Part 7

K: Place one (1121) Upright Inside and one (1122) Upright Outside centred on the top of (1117) Back Gable Beam. Use one (1188) Guide Spacer in the grooves of (1117) Back Gable Beam and one at the top of the uprights for proper spacing of Uprights. Attach Beam to Uprights with one #10 x 4" Wood Screw per upright. Remove (1188) Guide Spacer. (F3.16)

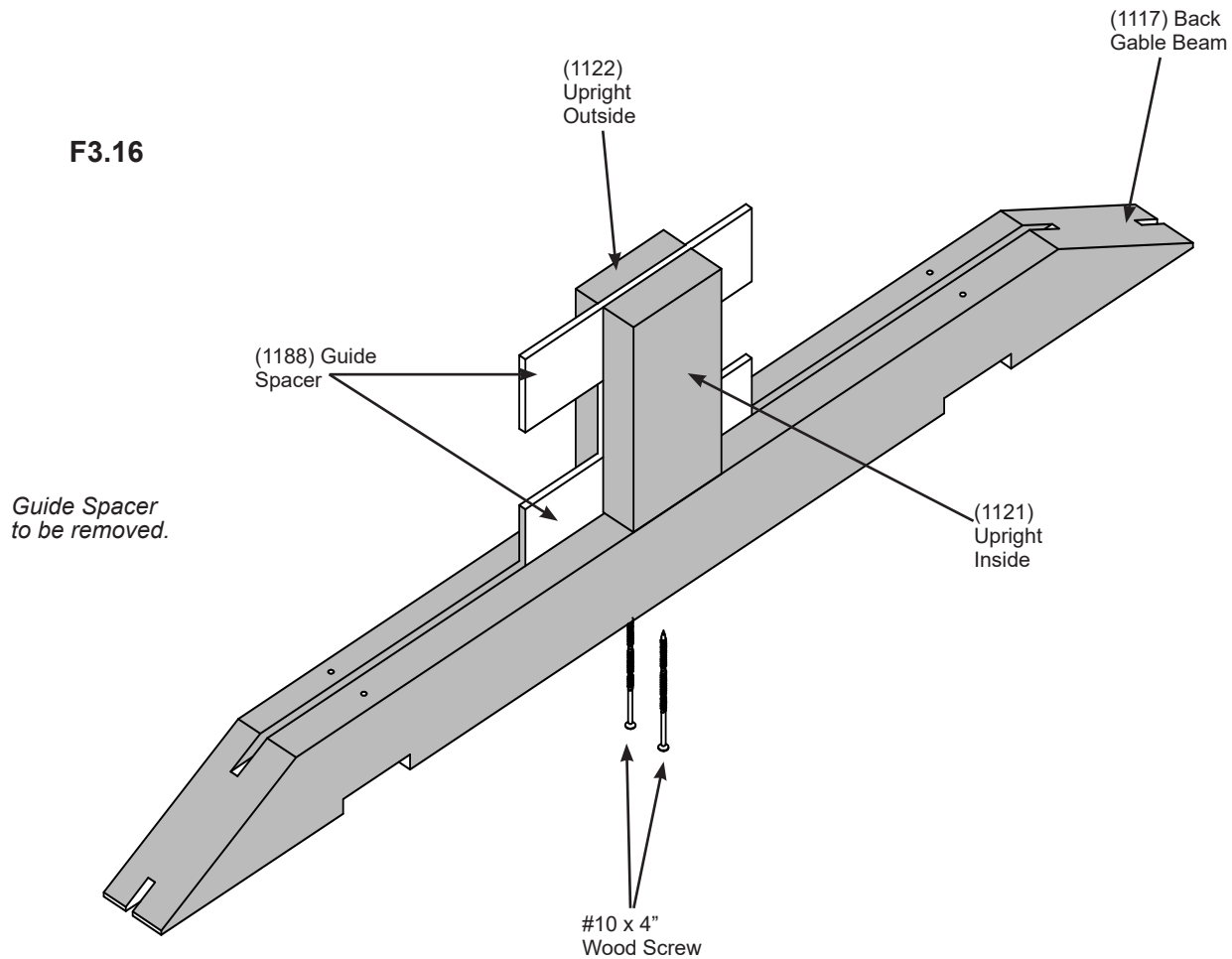

Wood Parts

- 1 x (1117) Back Gable Beam
- 1 x (1121) Upright Inside
- 1 x (1122) Upright Outside

Hardware

- 2 x #10 x 4" Wood Screw

Step 3: Back Wall Assembly Part 8

L: Place (1117) Back Gable Beam on top of (1113) Back Posts so notches on the bottom fit over the posts then attach with two #10 x 4" Wood Screws per post. (F3.17 and F3.18)

F3.17

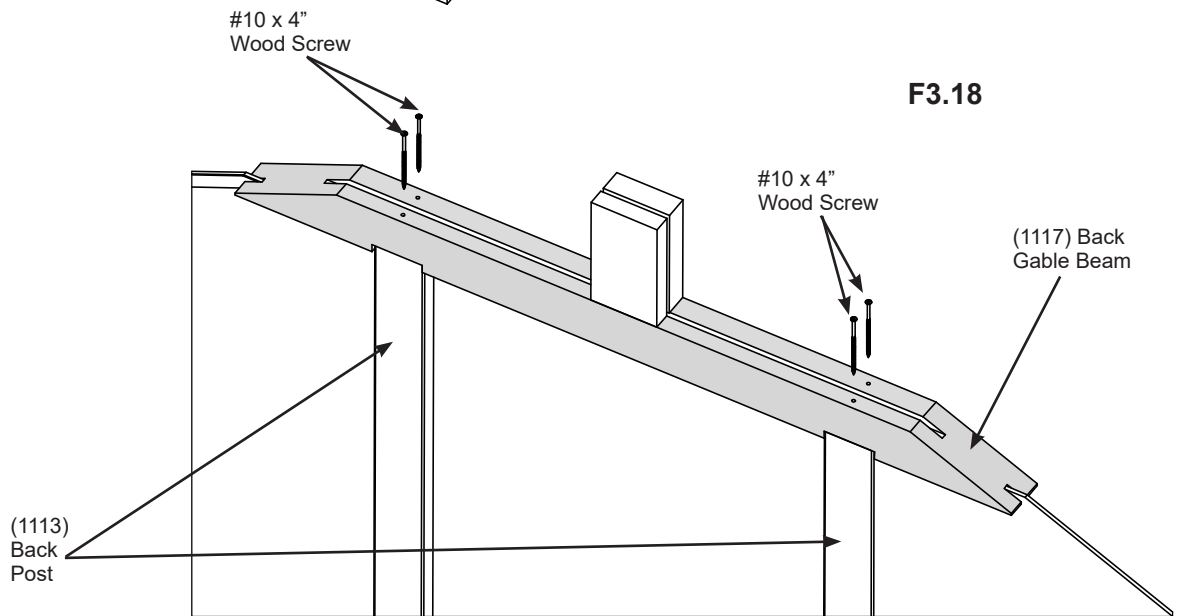
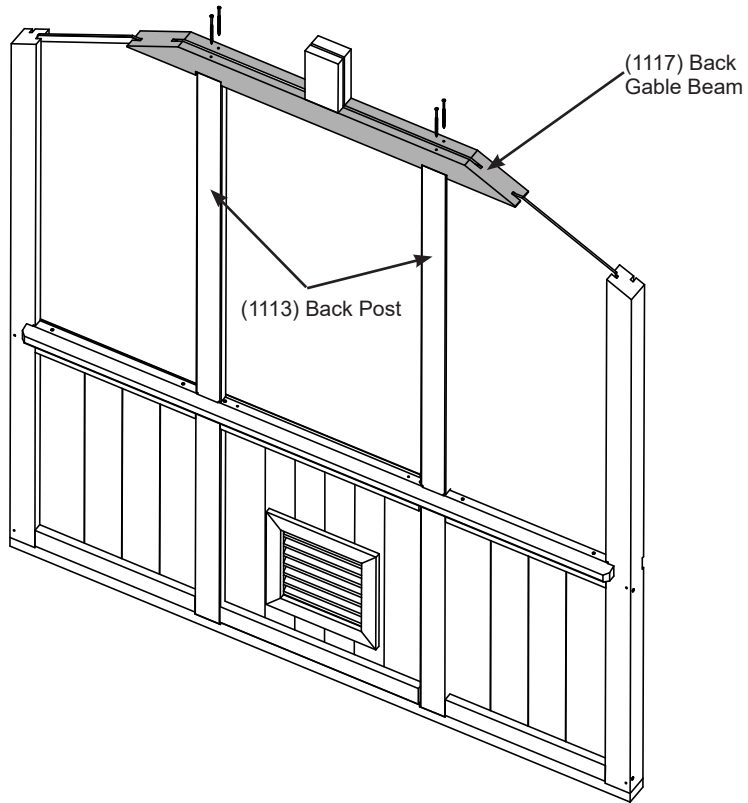

Hardware

4 x #10 x 4" Wood Screw

Step 3: Back Wall Assembly Part 9

Remove film from both sides of Gable Panel.

M: Refer to pages 16 and 17 and apply top and bottom tape to Gable Panel.

N: Slide Gable Panel down into the grooves of (1117) Back Gable Beam, in between (1121) Upright Inside and (1122) Upright Outside. Make sure the notch at the bottom is on the right side of the panel. The UV coated side must be to the outside of the frame. (F3.19, F3.20 and F3.21)

F3.19

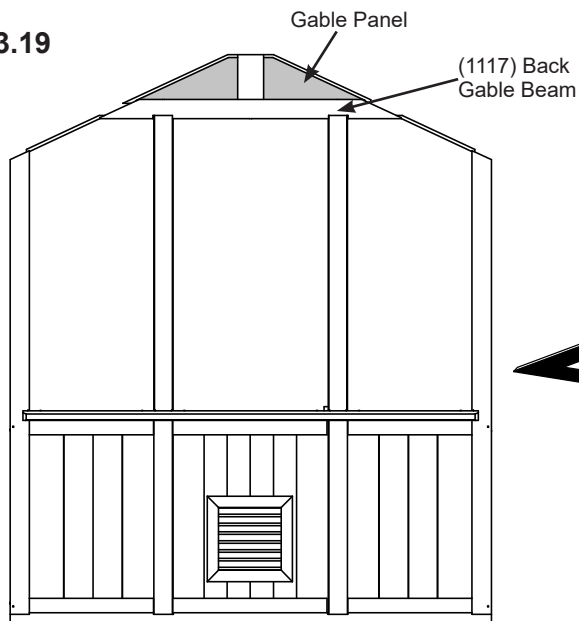

F3.20

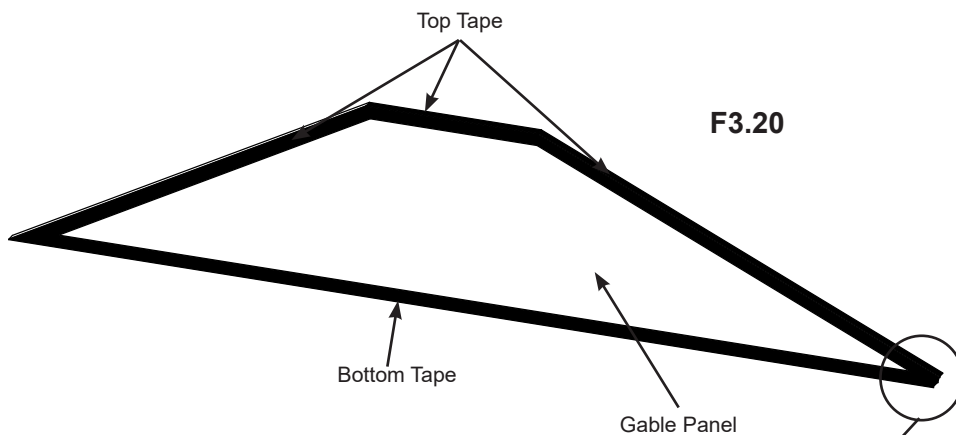

**F3.21
Outside View**

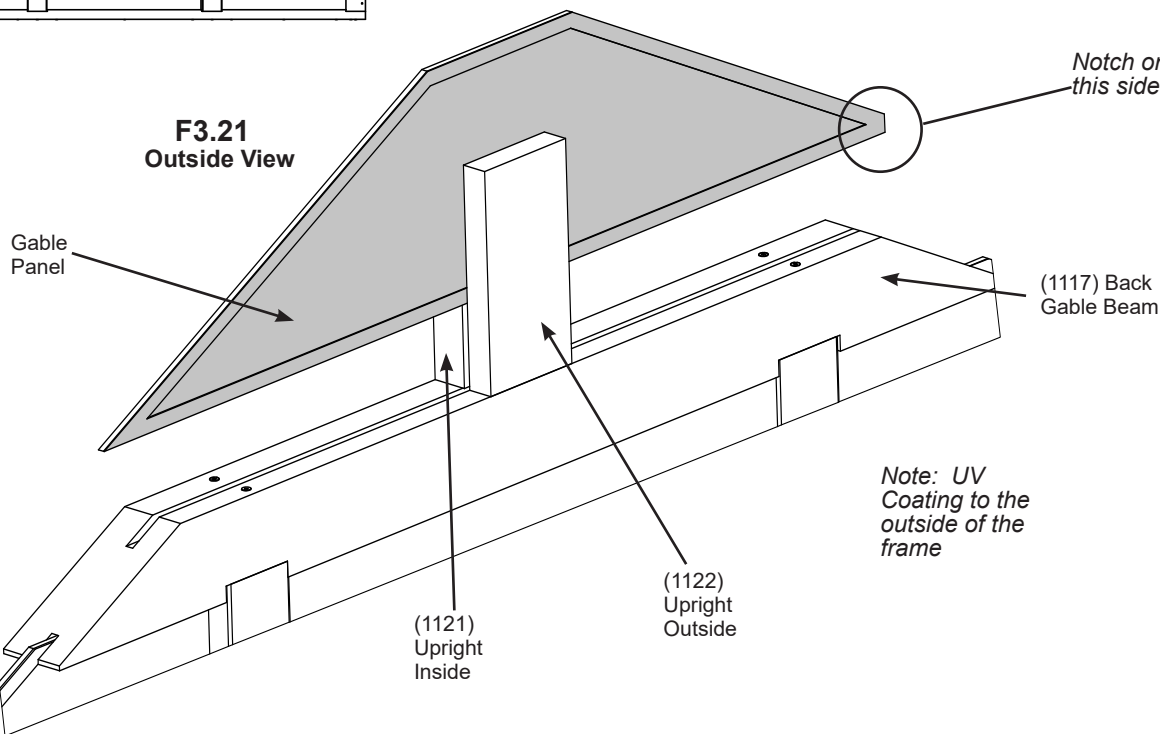

Components

- 1 x Gable Panel
- Top Tape
- Bottom Tape

Step 3: Back Wall Assembly

Part 10



O: Place one (1115) Right Roof Rafter and one (1116) Left Roof Rafter on each side of the frame so the ends overhang (1108) Left Post and (1109) Right Post by 1-1/2" (3.81 cm). They will sit on the uprights. Make sure grooves in rafters face inwards. Place one (1184) Peak Spacer between (1115) Right Roof Rafter and (1116) Left Roof Rafter so the detail is on the outside of the assembly. Attach rafters to posts with one #10 x 5-5/8" Wood Screw per post and to (1117) Back Gable Beam with one #10 x 4" Wood Screw per rafter. (F3.22 and F3.23)

P: Attach each rafter to Peak Spacer with one #10 x 4" Wood Screw per rafter. Attach (1184) Peak Spacer to rafters with two #8 x 2" Wood Screws. (F3.23 and F3.24)

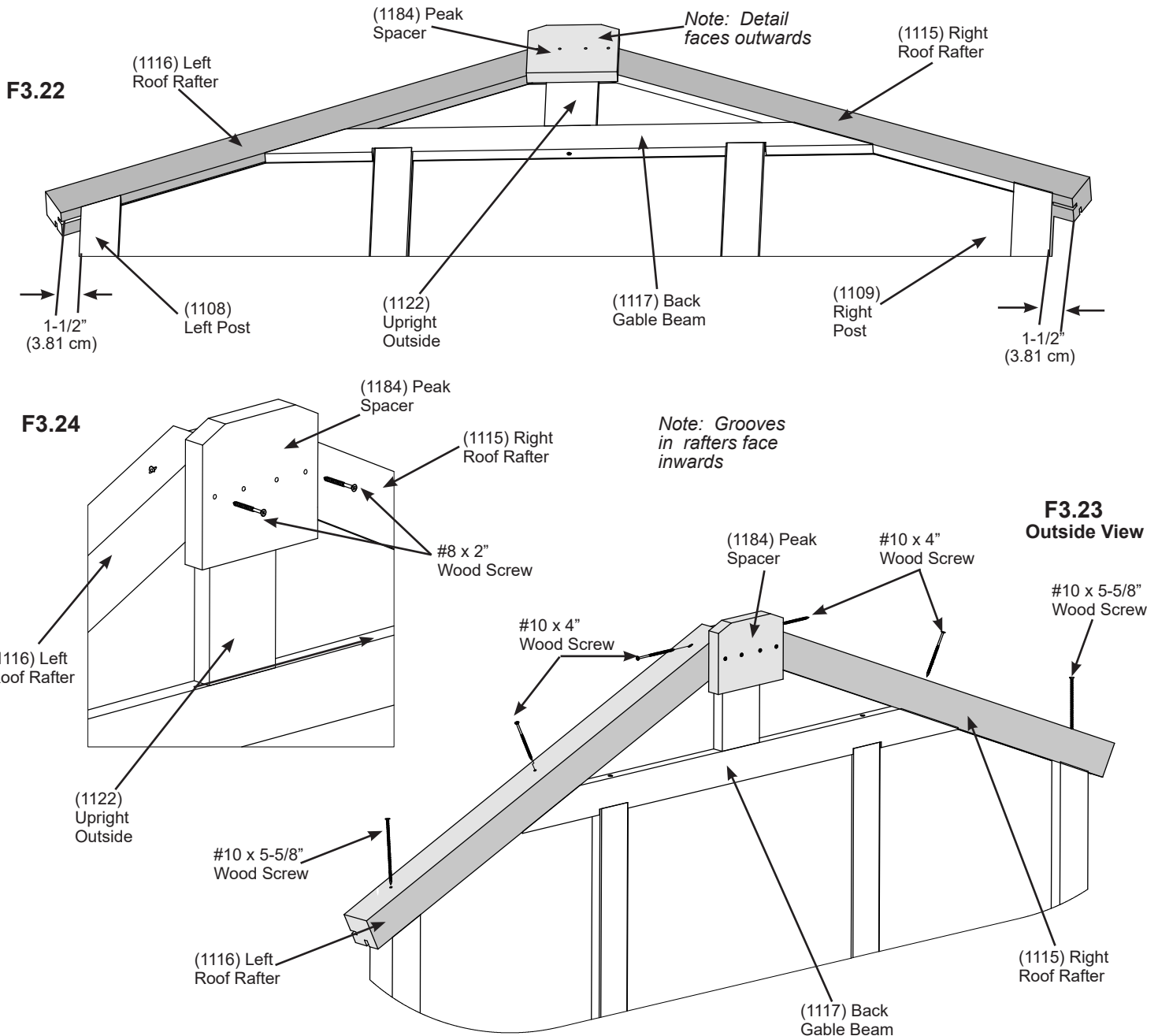

Wood Parts

- 1 x (1115) Right Roof Rafter
- 1 x (1116) Left Roof Rafter
- 1 x (1184) Peak Spacer

Hardware

- 2 x #10 x 5-5/8" Wood Screw
- 4 x #10 x 4" Wood Screw
- 2 x #8 x 2" Wood Screw

Step 3: Back Wall Assembly

Part 11

Q: On the inside of the frame attach four (1136) Inside Vent Trims around opening in (1155) Vent Wall Panel using two #8 x 2-1/2" Wood Screws per trim. (F3.25 and F3.26)

F3.25
Inside View

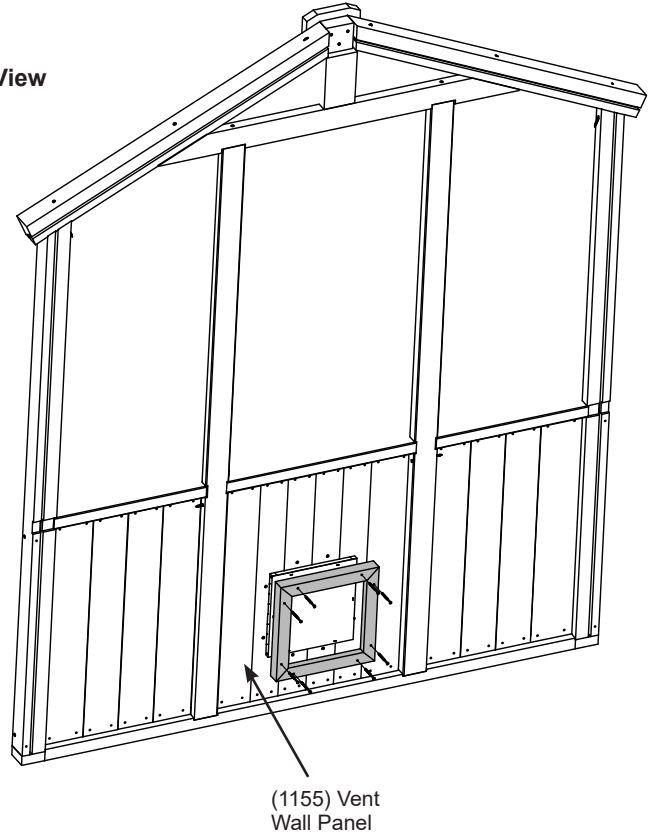

F3.26

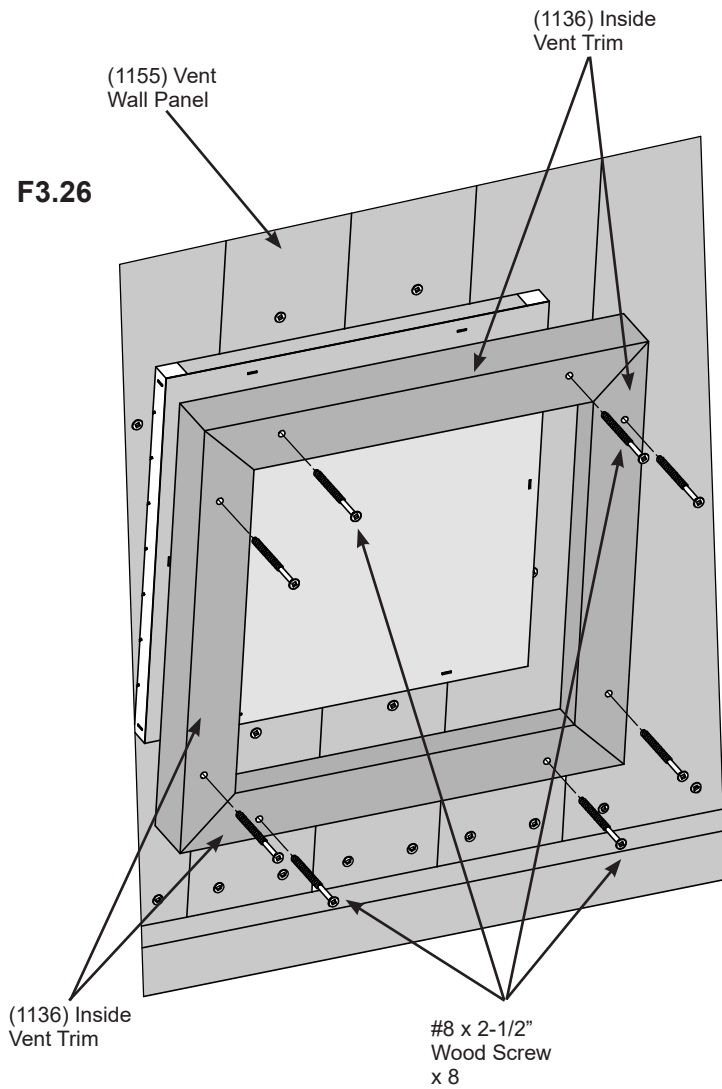

Wood Parts

4 x (1136) Inside Vent Trim

Hardware

8 x #8 x 2-1/2" Wood Screw

Step 4: Side Wall Assembly Part 1

A: At the bottom of one (1110) Mid Post attach one (1118) Side Base with two #10 x 4" Wood Screws. Make sure grooves in posts are facing the sides and angle at the top of the post is towards the front. (F4.1, F4.2 and F4.3)

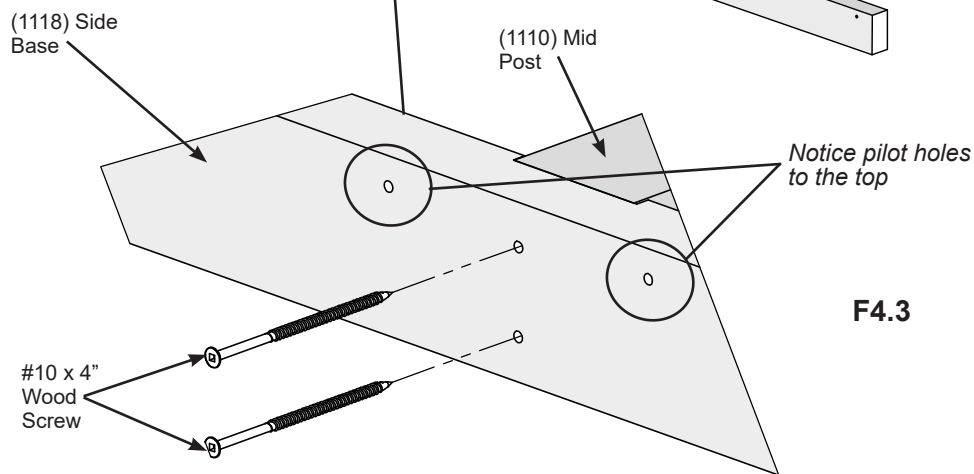
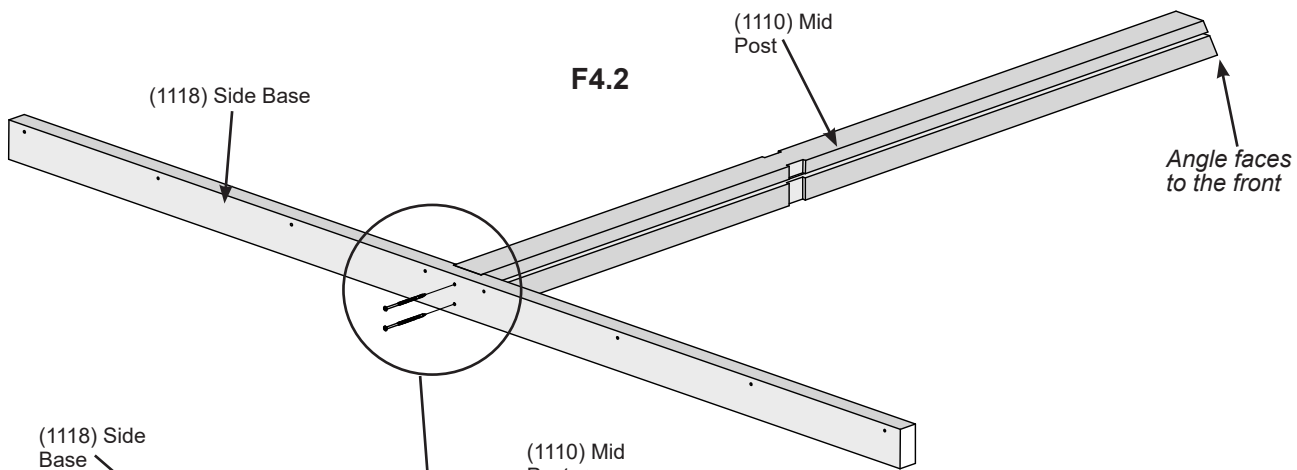
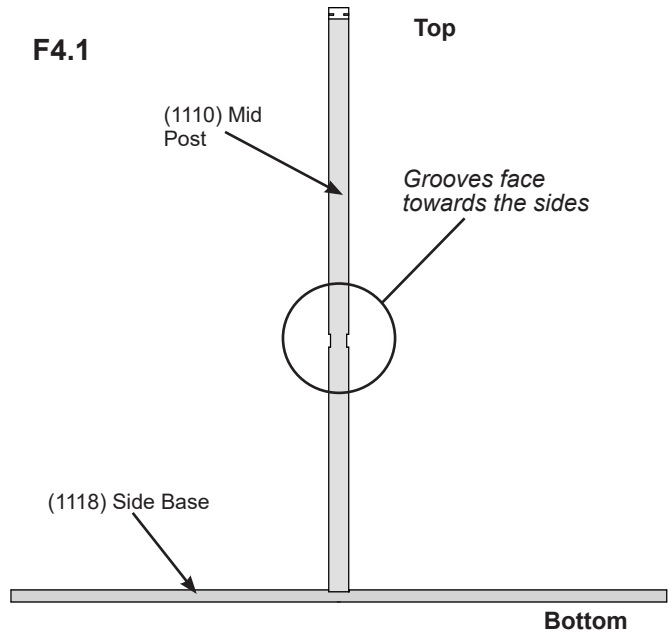

Wood Parts

2 x (1110) Mid Post
2 x (1118) Side Base

Hardware

4 x #10 x 4" Wood Screw

Step 4: Side Wall Assembly Part 2

B: On each side of (1110) Mid Post, in the grooves, slide one (1152) Side Wall Panel down so they rest tight to the top of the (1118) Side Base. Ends of (1118) Side Base and each (1152) Side Wall Panel should be flush. The tongue of the panel will overhang the base. Attach (1118) Side Base to each (1152) Side Wall Panel with four #8 x 3" Wood Screws per panel. (F4.4, F4.5 and F4.6)

C: Using one Corner Bracket per (1152) Side Wall Panel attach (1110) Mid Post to each panel with two #10 x 1-1/4" Pan Screws per bracket. (F4.4 and F4.7)

D: Repeat Steps A-C for a second Side Wall Assembly.

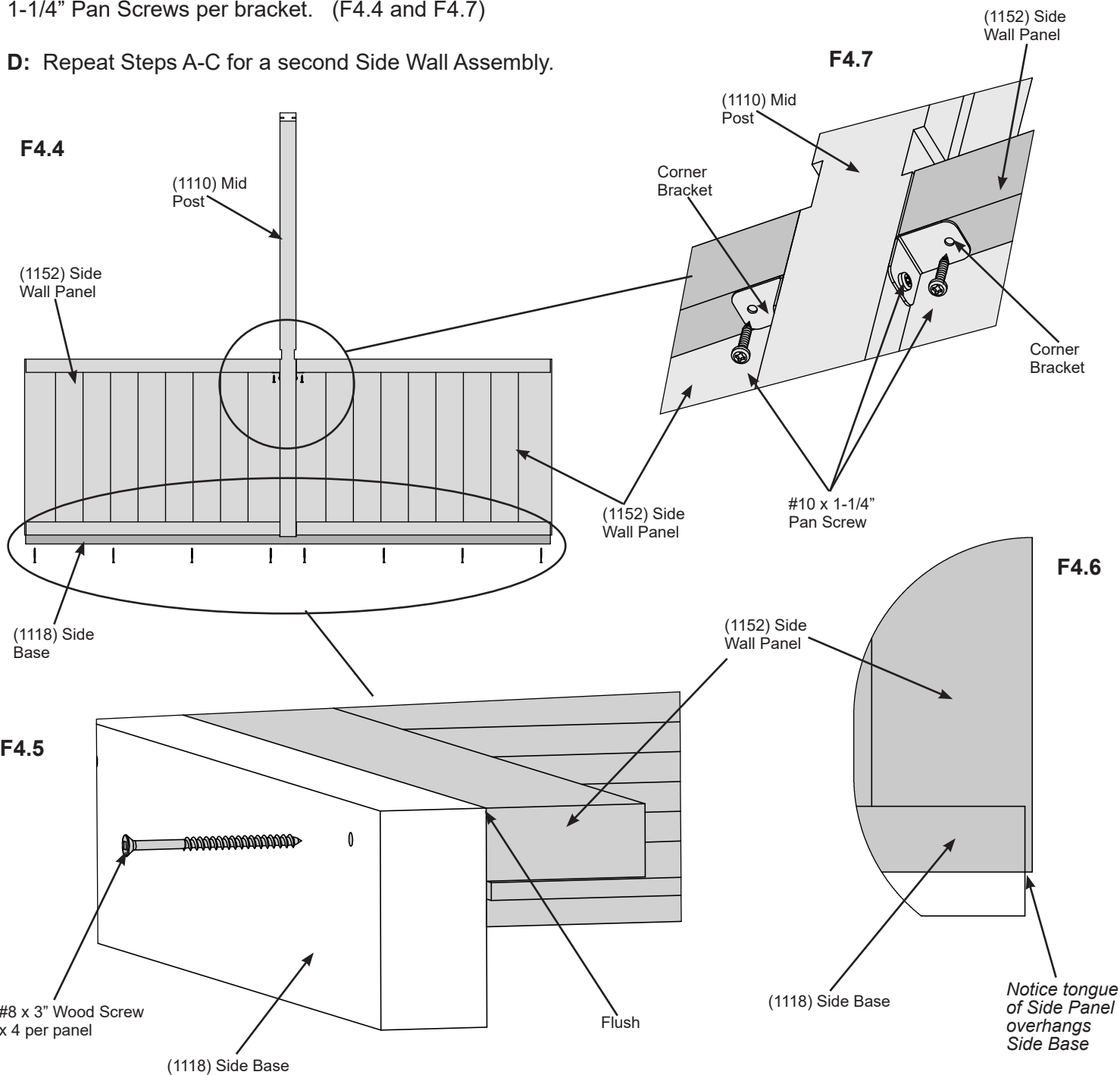

Wood Parts

4 x (1152) Side Wall Panel

Components

4 x Corner Bracket

Hardware

16 x #8 x 3" Wood Screw

8 x #10 x 1-1/4" Pan Screw

Step 5: Connect Wall Assemblies Part 1

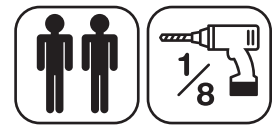

If using a treated lumber base it should be placed in the final location. Images will only show treated lumber base. Same instructions apply for concrete base, unless otherwise specified.

A: With a helper, stand Back Wall Assembly on base then slide Side Wall Assemblies into grooves of (1108) Left Post and (1109) Right Post. Pre-drill with a 1/8" drill bit then attach Back Wall Assembly to Side Wall Assemblies with two #10 x 4" Wood Screws per side. (F5.1, F5.2 and F5.3)

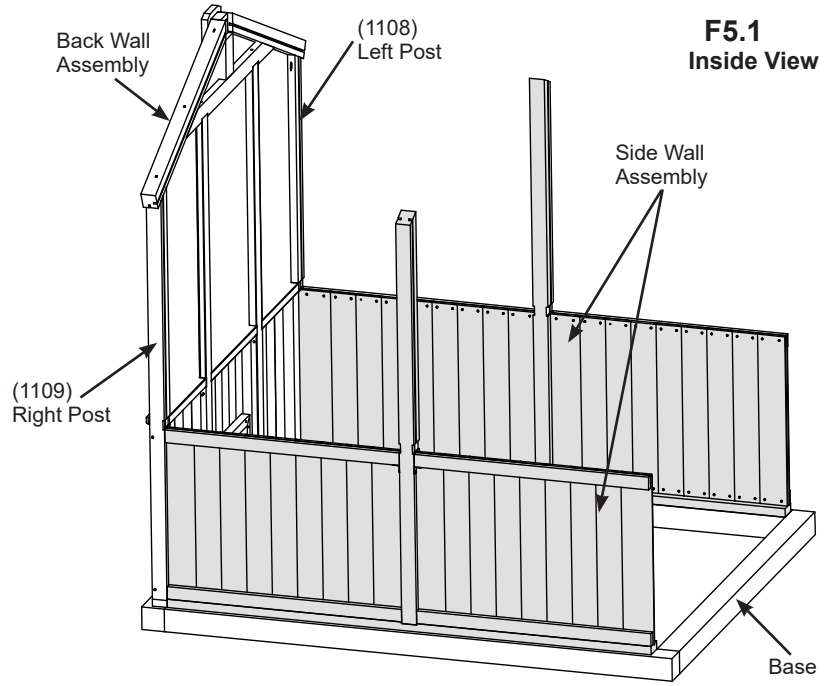

F5.2
Inside View

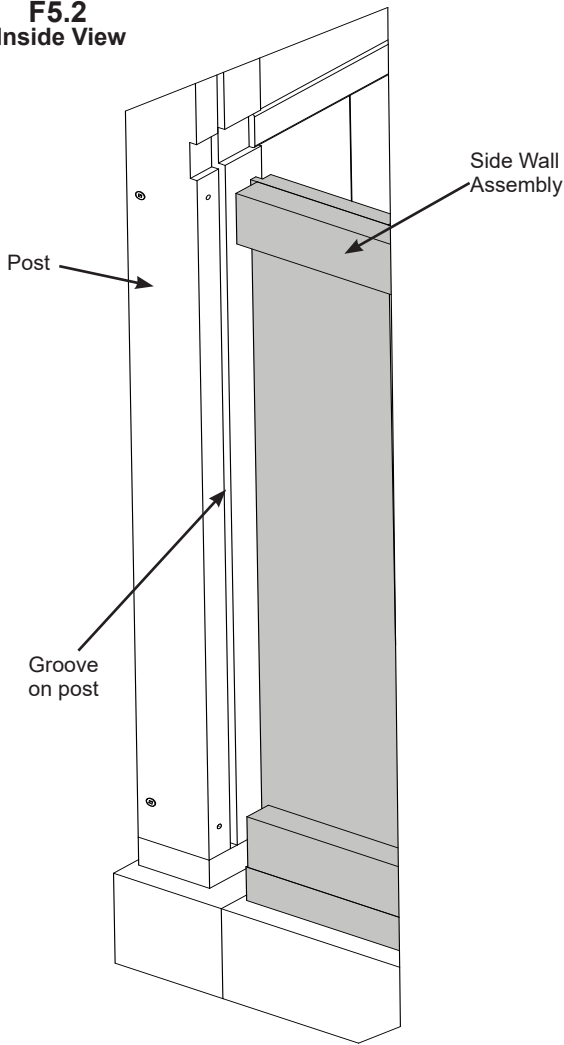

F5.3
Outside View

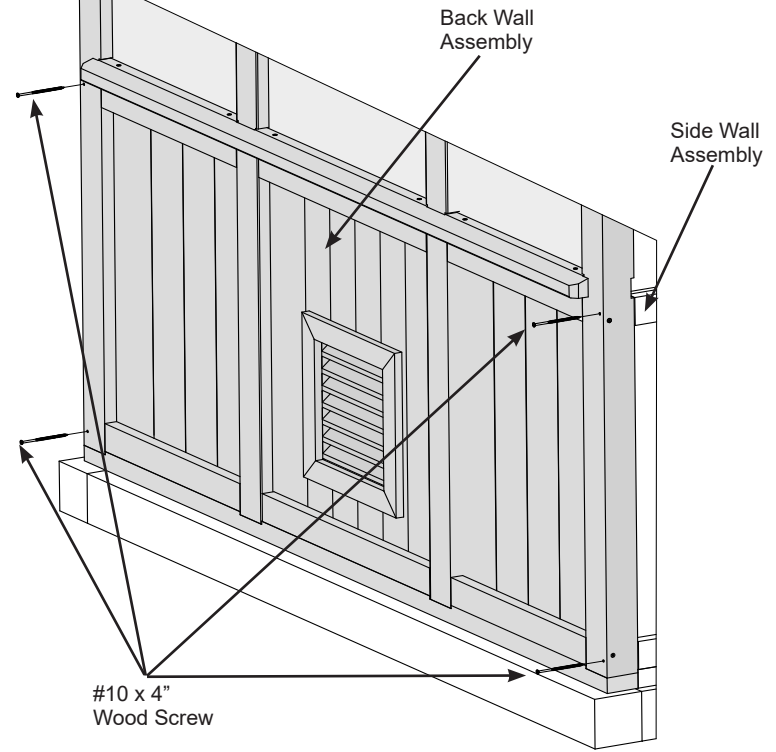

Hardware

4 x #10 x 4" Wood Screw

Step 5: Connect Wall Assemblies Part 2

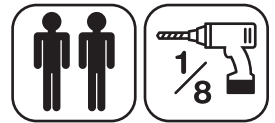

B: With a helper, stand up Front Wall Assembly and slide so Side Wall Assemblies fit into grooves of (1108) Left Post and (1109) Right Post. Pre-drill with a 1/8" drill bit then attach Front Wall Assembly to Side Wall Assemblies with two #10 x 4" Wood Screws per side. (F5.4 and F5.5)

F5.4

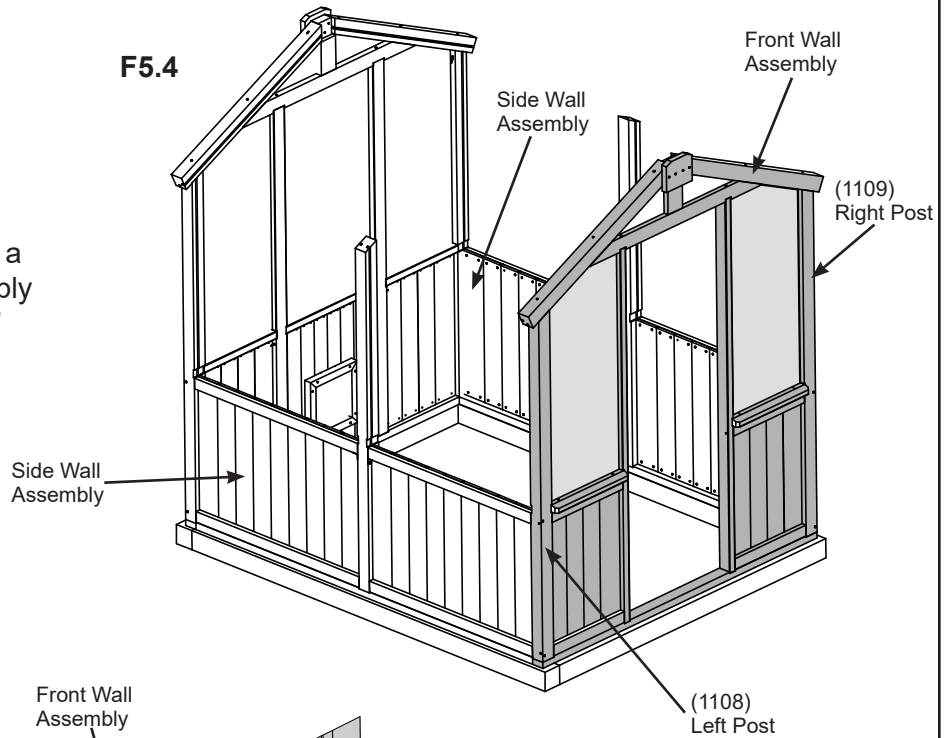

**F5.5
Outside View**

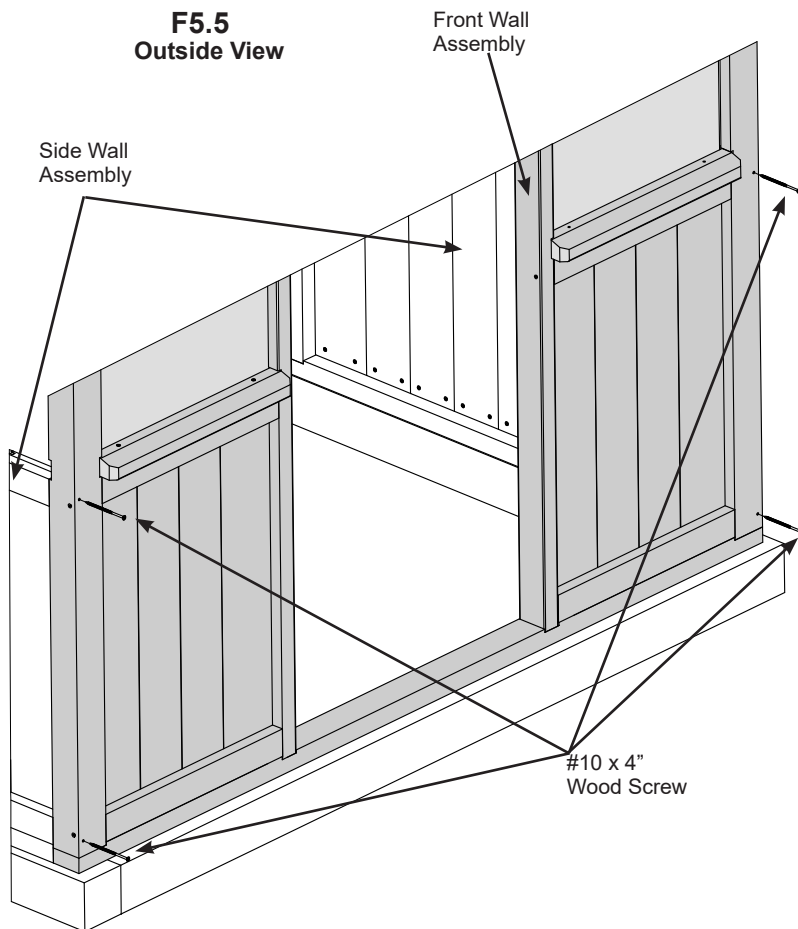

Hardware

4 x #10 x 4" Wood Screw

Step 6: Square Assembly

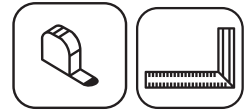

A: Make sure assembly is square and the diagonal distance from the inside of one post to the inside of the opposite post is 9' 2-7/16" (2.806 m). (F6.1)

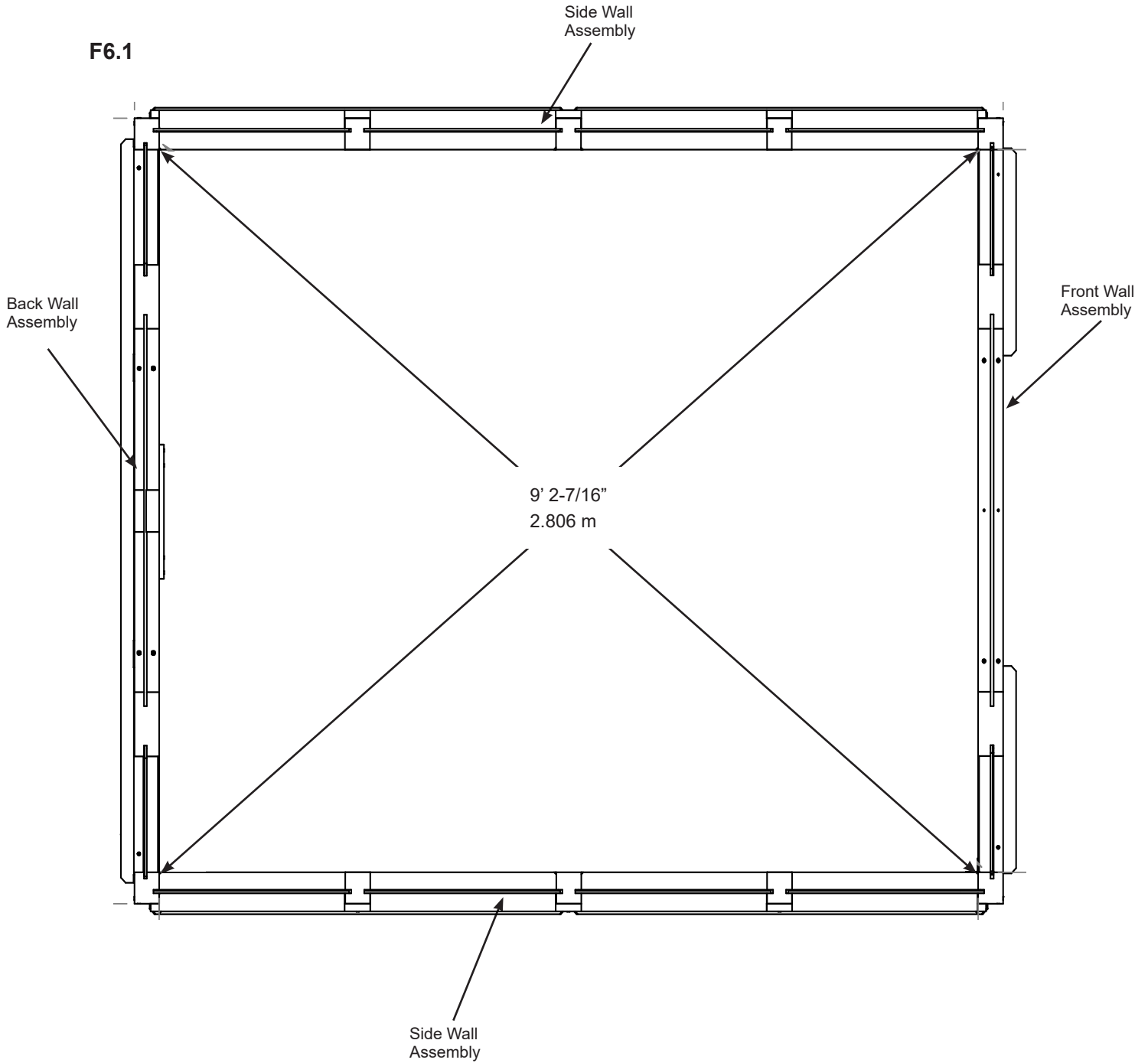

Step 7: Attach Side Wall Sills

A: Place one (1107) Side Wall Sill on top of each (1152) Side Wall Panel. Use one (1188) Guide Spacer in the grooves of each post and (1107) Side Wall Sill to line up posts with (1110) Mid Posts. Attach (1107) Side Wall Sills to (1152) Side Wall Panels with three #8 x 3" Wood Screws per panel. Remove (1188) Guide Spacer. (F7.1 and F7.2)

F7.1

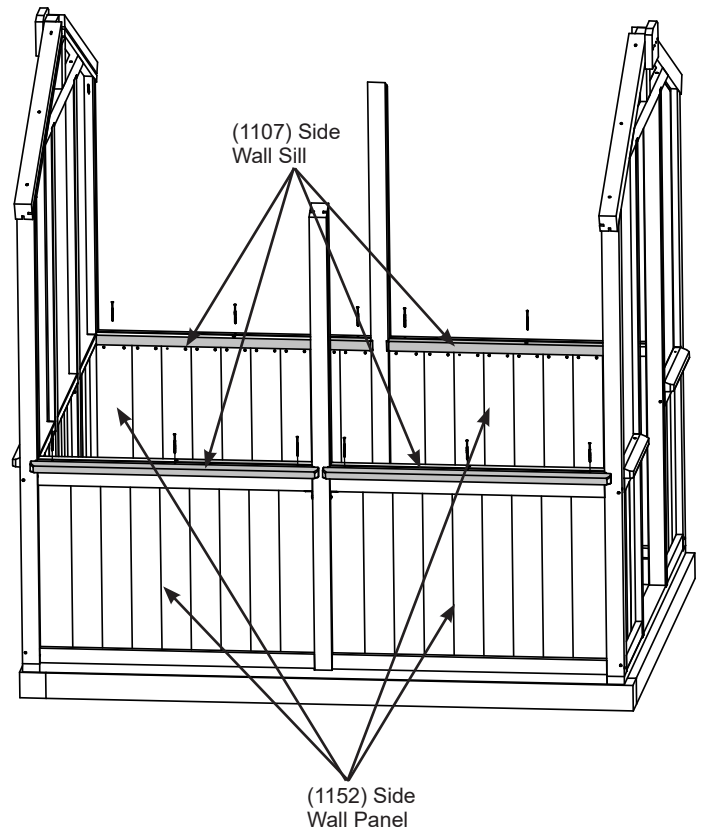

F7.2

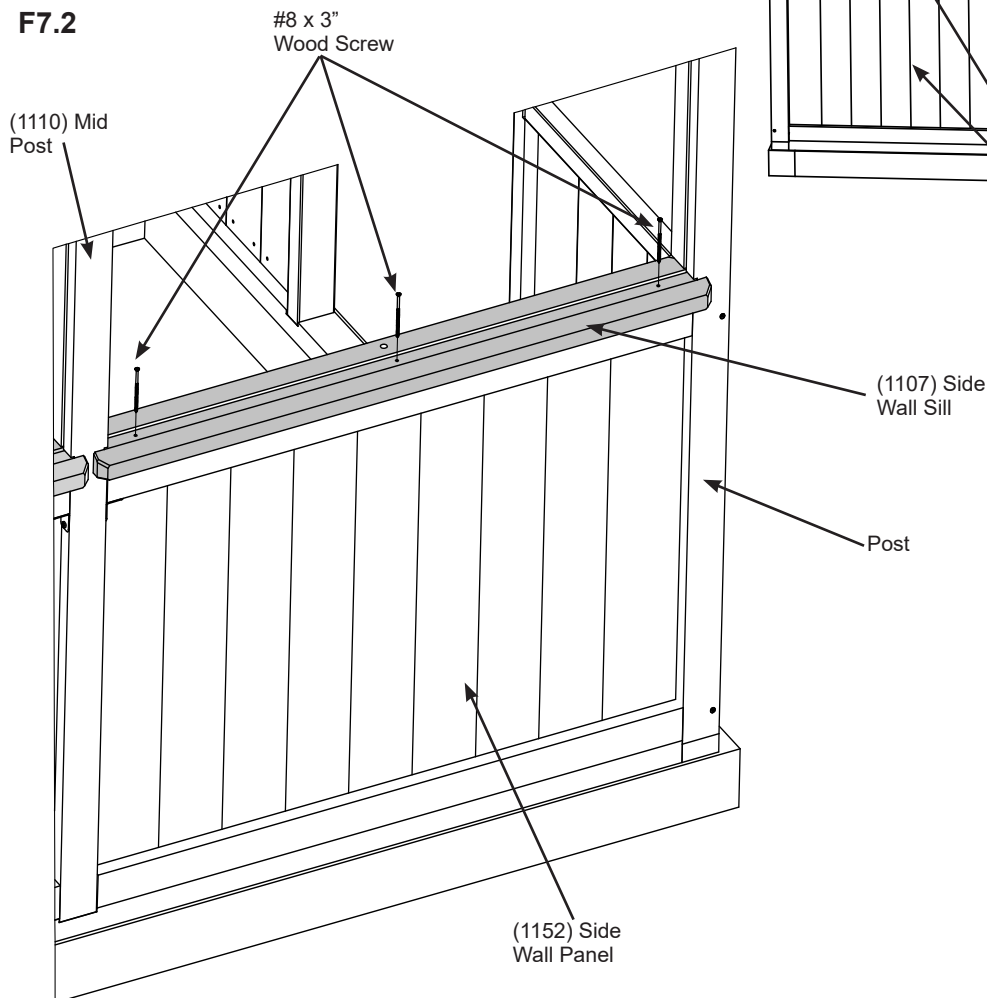

Guide Spacers to sit in grooves of Posts and Side Wall Sill to align Side Wall Sill correctly, then to be removed.

Wood Parts

4 x (1107) Side Wall Sill

Hardware

12 x #8 x 3" Wood Screw

Step 8: Attach Corner Brackets Part 1

A: On the inside of the assembly, using one Corner Bracket per corner connect (1119) Front Base and (1120) Back Base to (1118) Side Bases with two #10 x 1-1/4" Pan Screws per bracket. (F8.1 and F8.2)

F8.1

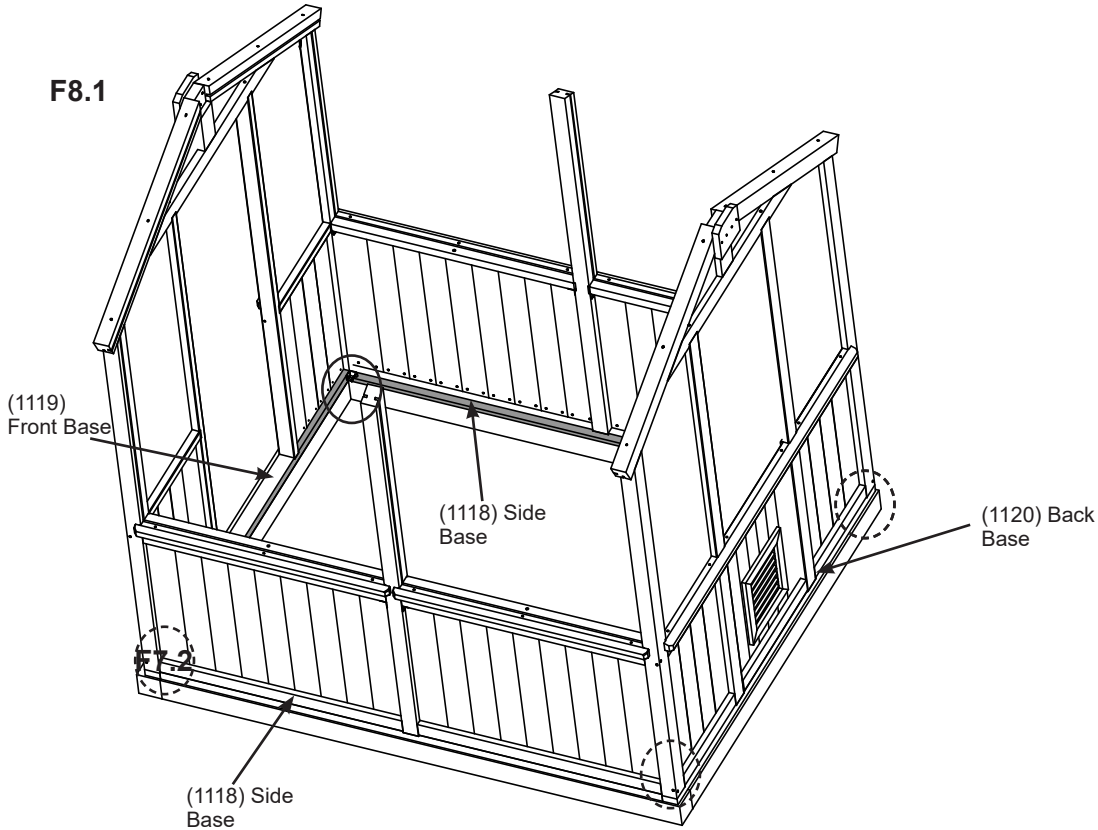

F8.2

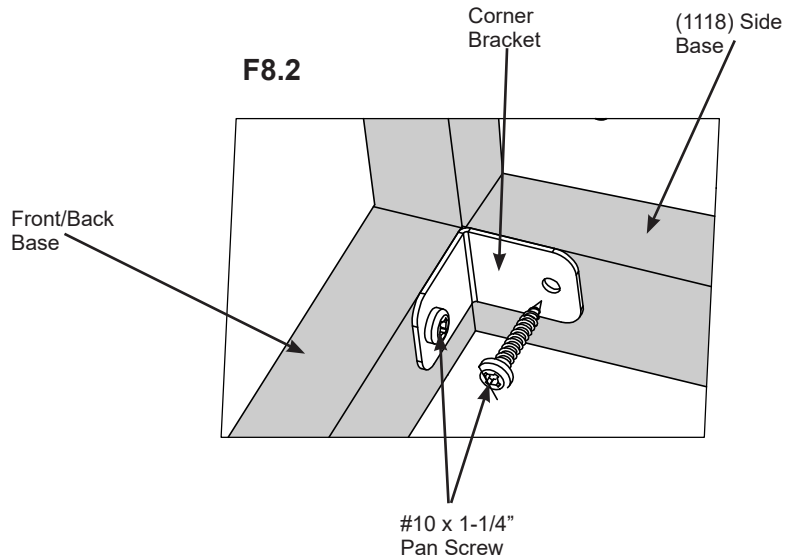

Components

4 x Corner Bracket

Hardware

8 x #10 x 1-1/4" Pan Screw

Step 8: Attach Corner Brackets Part 2

B: On the inside of the assembly, underneath each (1107) Side Wall Sill, using one Corner Bracket per corner connect each (1108) Left Post, (1109) Right Post and (1110) Mid Post to each (1107) Side Wall Sill with two #10 x 1-1/4" Pan Screws per bracket. (F8.3, F8.4 and F8.5)

F8.3

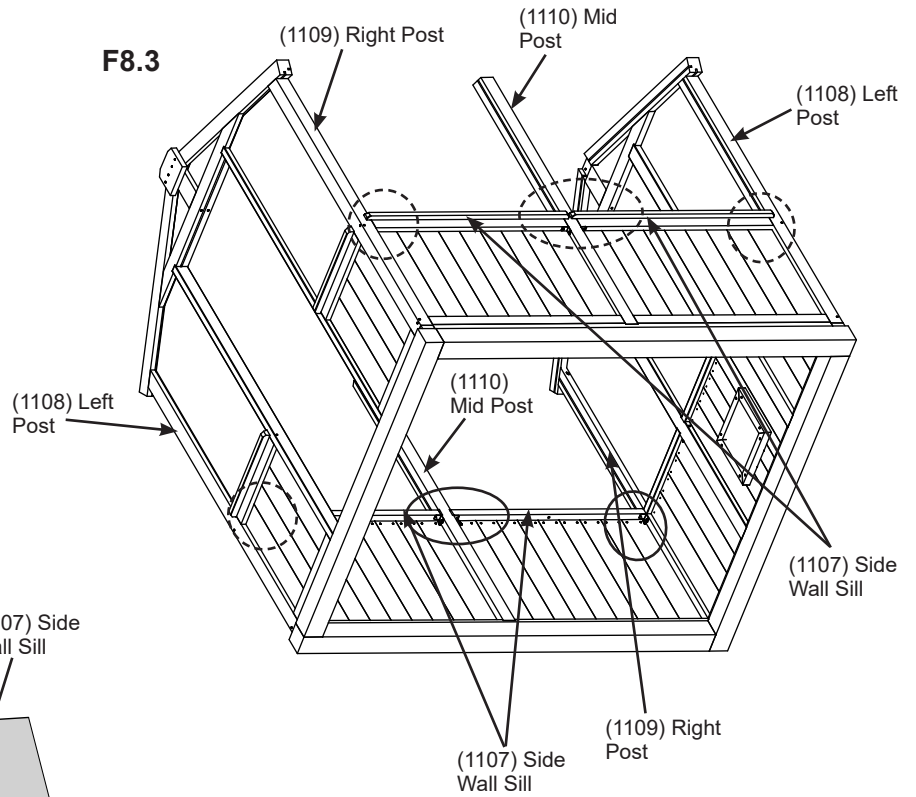

F8.4

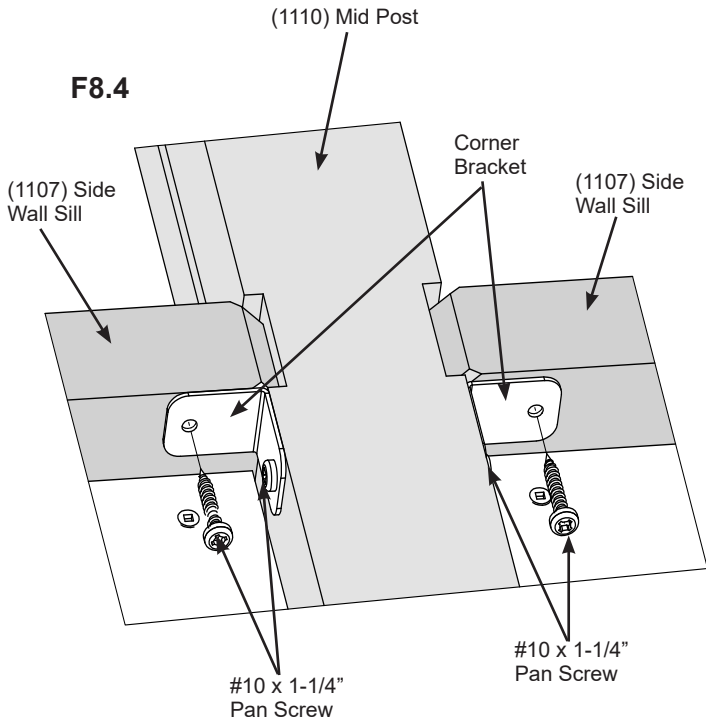

F8.5

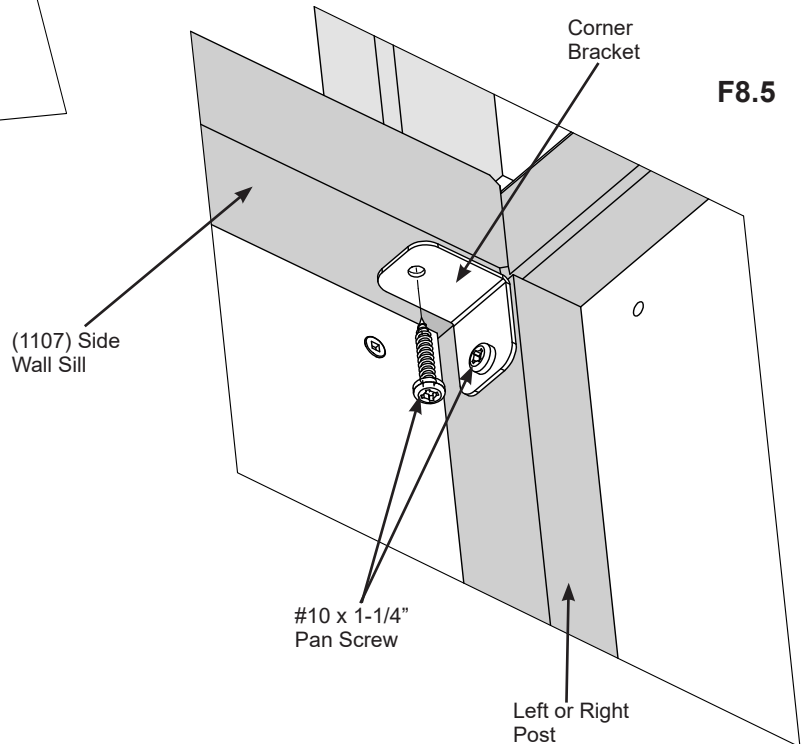

Components

8 x Corner Bracket

Hardware

16 x #10 x 1-1/4" Pan Screw

Step 9: Secure Assembly to Base



A: Using the purchased hardware as mentioned on page 7, pre-drill then secure the Front Wall, Back Wall and Side Walls to the base in the locations shown in F9.1.

F9.1

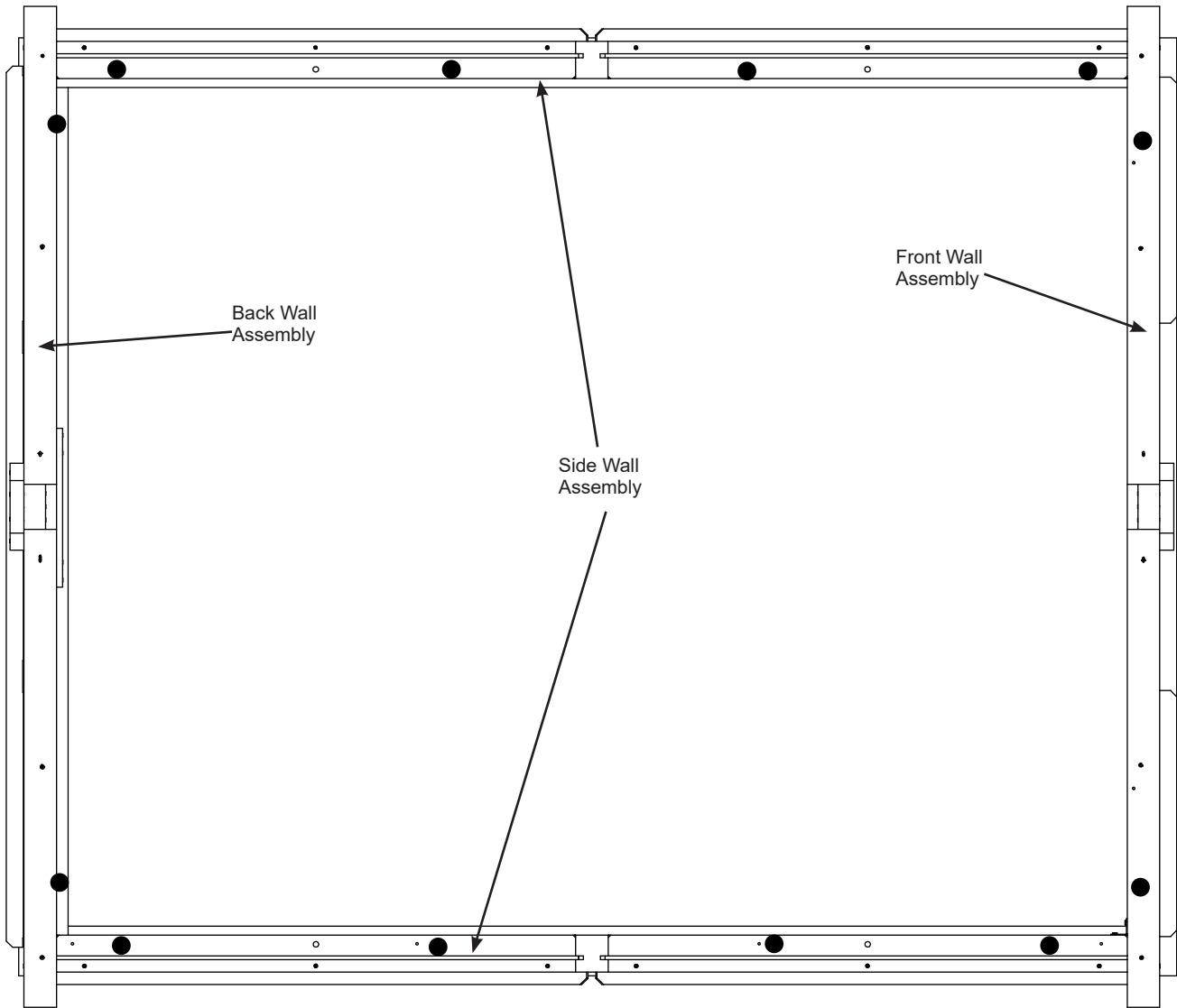



Step 10: Attach Side Wall Top

A: On each Side Wall Assembly place one (1125) Side Wall Top tight to bottom of (1115) Right Roof Rafters and (1116) Left Roof Rafters, so notches are at the top. Centre notch to be flush to the top of (1110) Mid Post. Attach (1125) Side Wall Top to (1108) Left Posts and (1109) Right Posts with one #8 x 2-1/2" Wood Screw per post. Screws are to be installed at an angle. (F10.1, F10.2 and F10.3)

B: Attach (1125) Side Wall Tops to each (1110) Mid Post with one #8 x 2" Wood Screw per post. (F10.1 and F10.4)

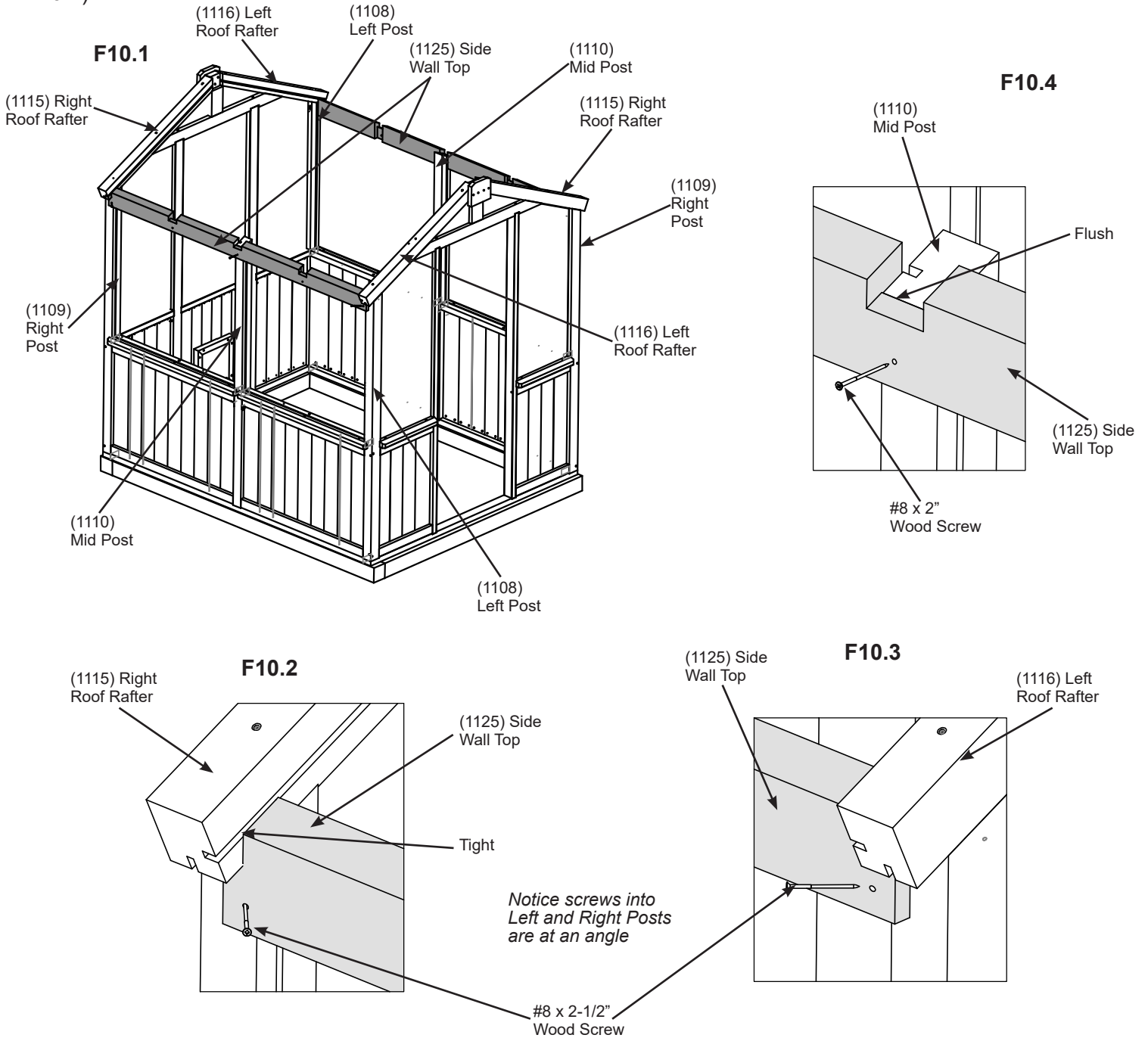

Wood Parts

2 x (1125) Side Wall Top

Hardware

4 x #8 x 2-1/2" Wood Screw

2 x #8 x 2" Wood Screw

Step 11: Side Wall Panel Assembly Part 1

Remove film from both sides of Side Wall Panels.

A: Refer to pages 16 and 17 and apply top and bottom tape to Side Wall Panels.

B: Put Side Wall Panel in the grooves of (1107) Side Wall Sill then slide into grooves of Left and Right Posts. Make sure the notch at the bottom is always on the right side of the panel from outside of the assembly. The UV coated side must be to the outside of the assembly. (F11.1, F11.2 and F11.3)

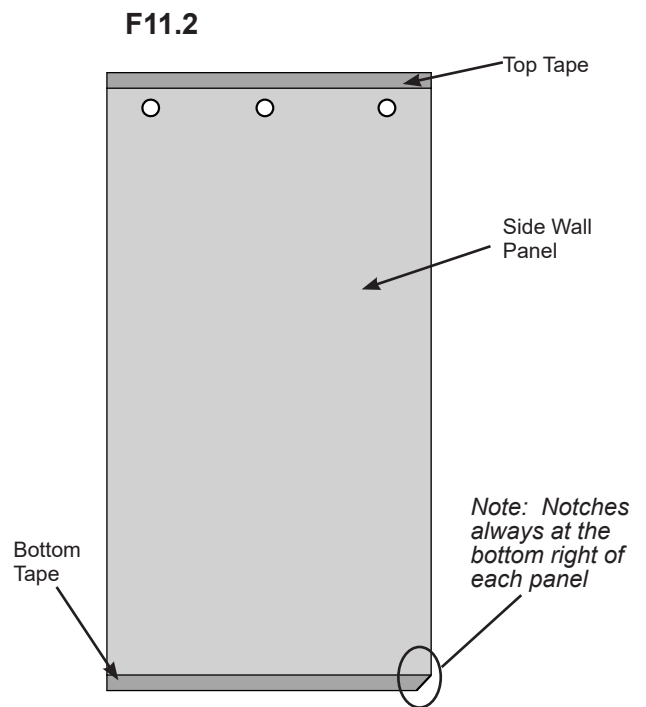
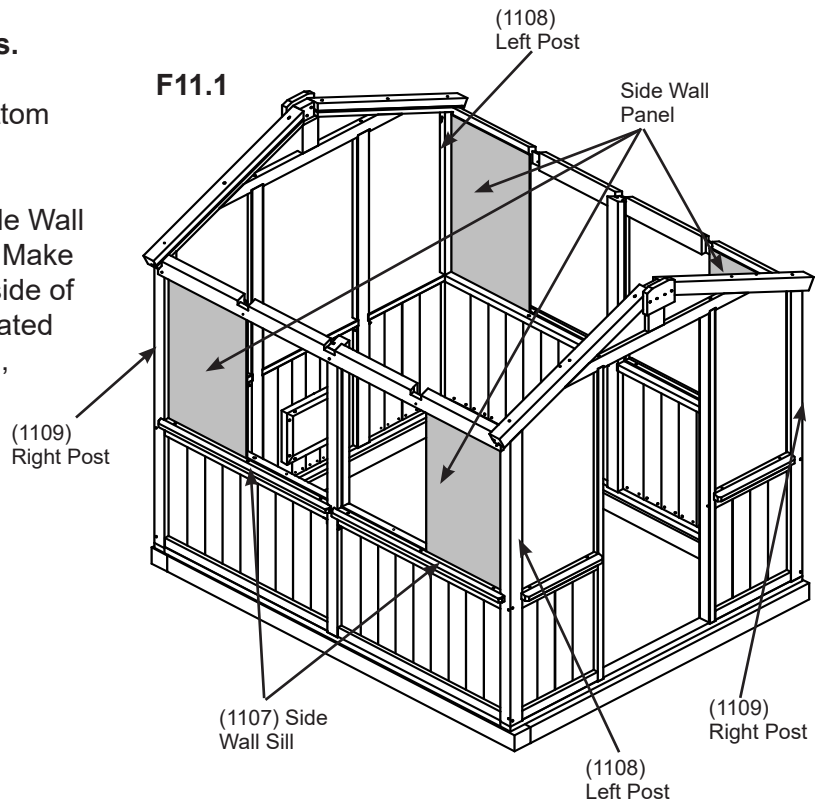
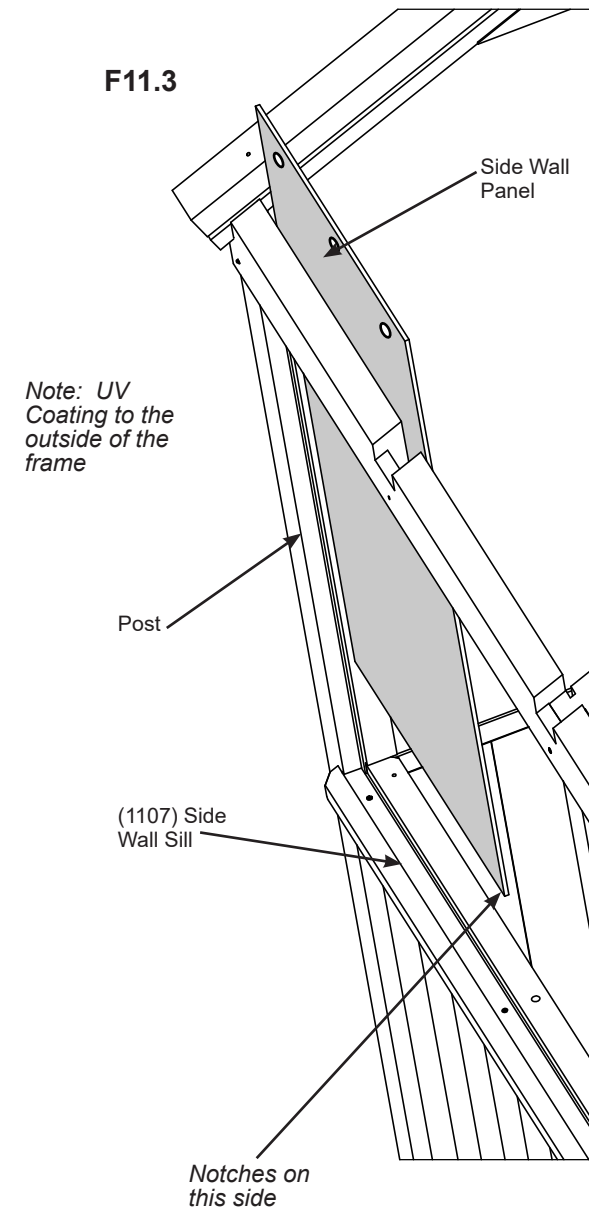

Components

4 x Side Wall Panel
Top Tape
Bottom Tape

Step 11: Side Wall Panel Assembly Part 2

C: Slide one (1144) Short Post Assembly down along the sides of each Side Wall Panel so they fit in the notches of (1125) Side Wall Tops. Dowel is at the bottom and fits in (1107) Side Wall Sills. Note the direction of the angle at the top. (F11.4, F11.5 and F11.6)

D: Attach (1125) Side Wall Tops to each (1144) Short Post Assembly with one #8 x 2" Wood Screw per post. (F11.4 and F11.7)

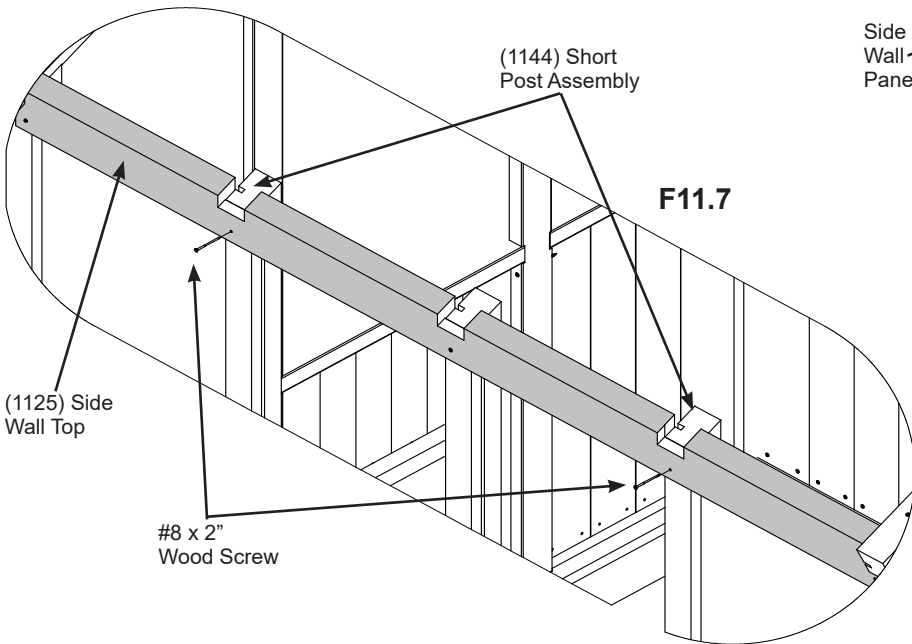
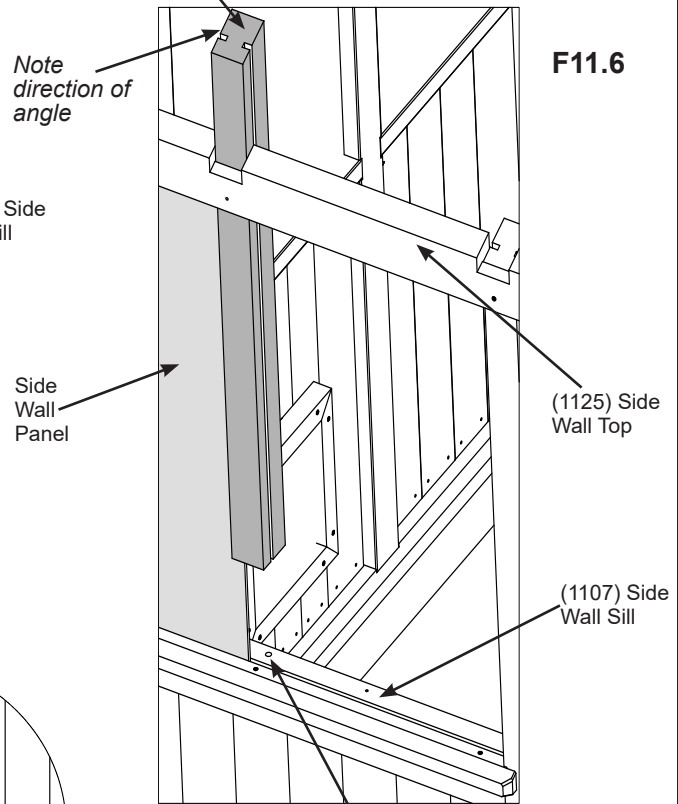
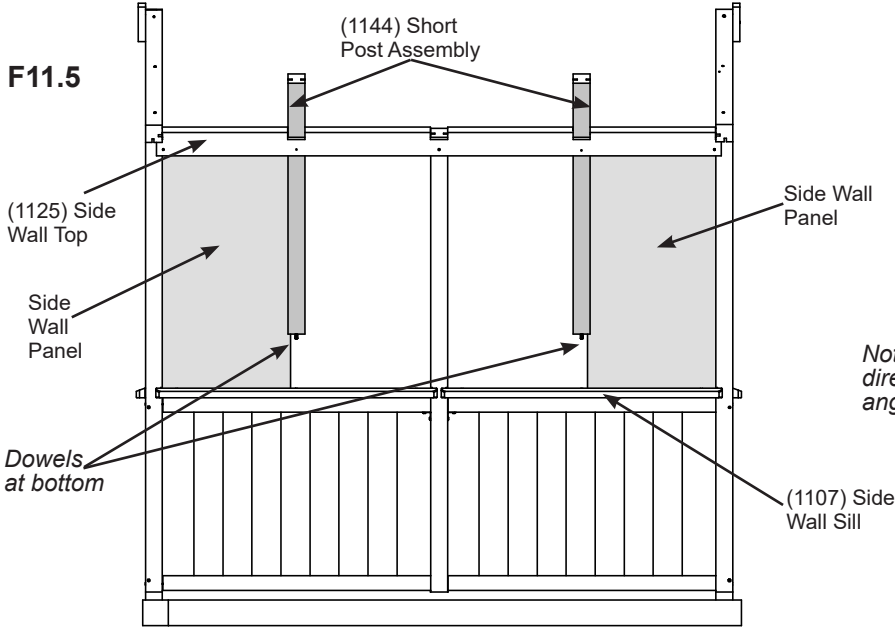
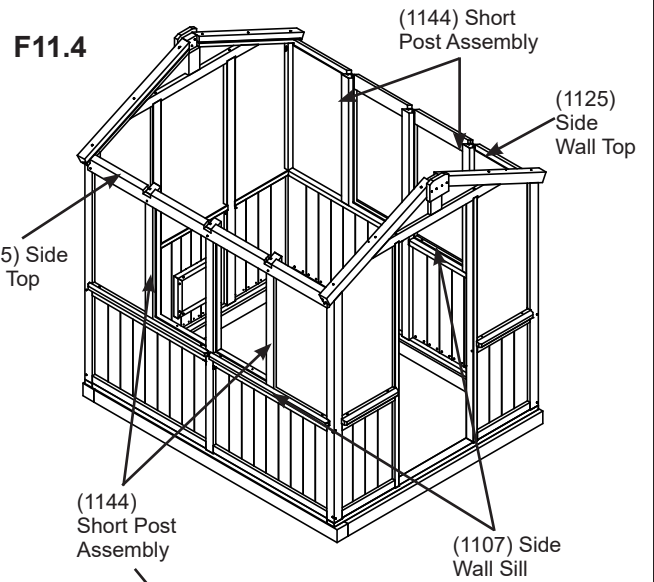

Wood Parts

4 x (1144) Short Post Assembly

Hardware

4 x #8 x 2" Wood Screw

Step 11: Side Wall Panel Assembly Part 3

Remove film from both sides of Side Wall Panels.

E: Refer to pages 16 and 17 and apply top and bottom tape to Side Wall Panels.

F: In the grooves of (1144) Short Post Assemblies and (1110) Mid Posts slide Side Wall Panels down to fit in the grooves of (1107) Side Wall Sills. Make sure the notch at the bottom is always on the right side of the panel from outside of the assembly. (F11.8)

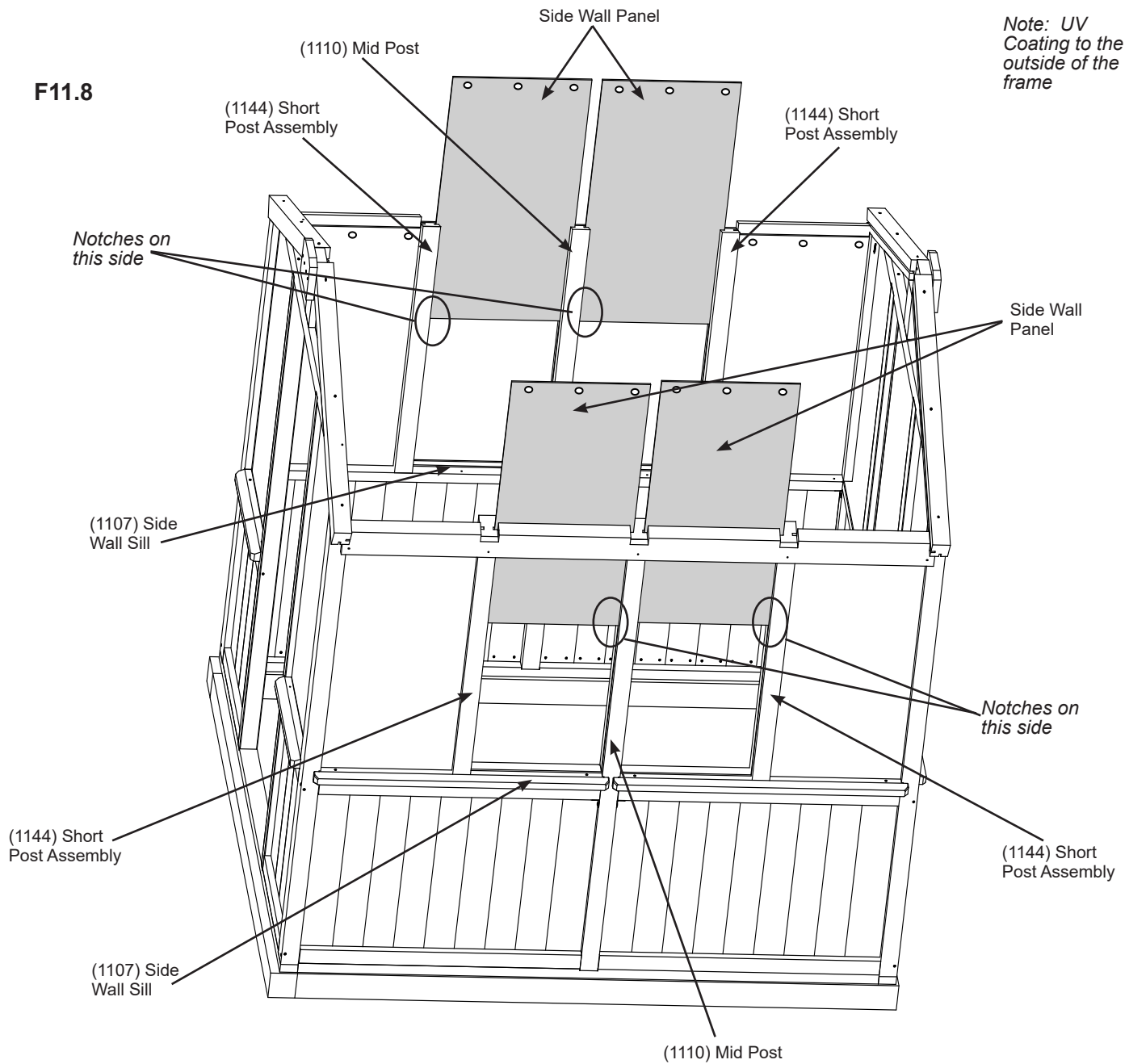

Components

4 x Side Wall Panel
Top Tape
Bottom Tape

Step 11: Side Wall Panel Assembly Part 4

G: On the top of each Side Wall Panel place one PC U-Channel. (F11.9 and F11.10)

H: Attach each Side Wall Panel to (1125) Side Wall Tops using three #10 x 1-1/4" Black Pan Screws with EPDM washers per panel. (F11.9 and F11.10)

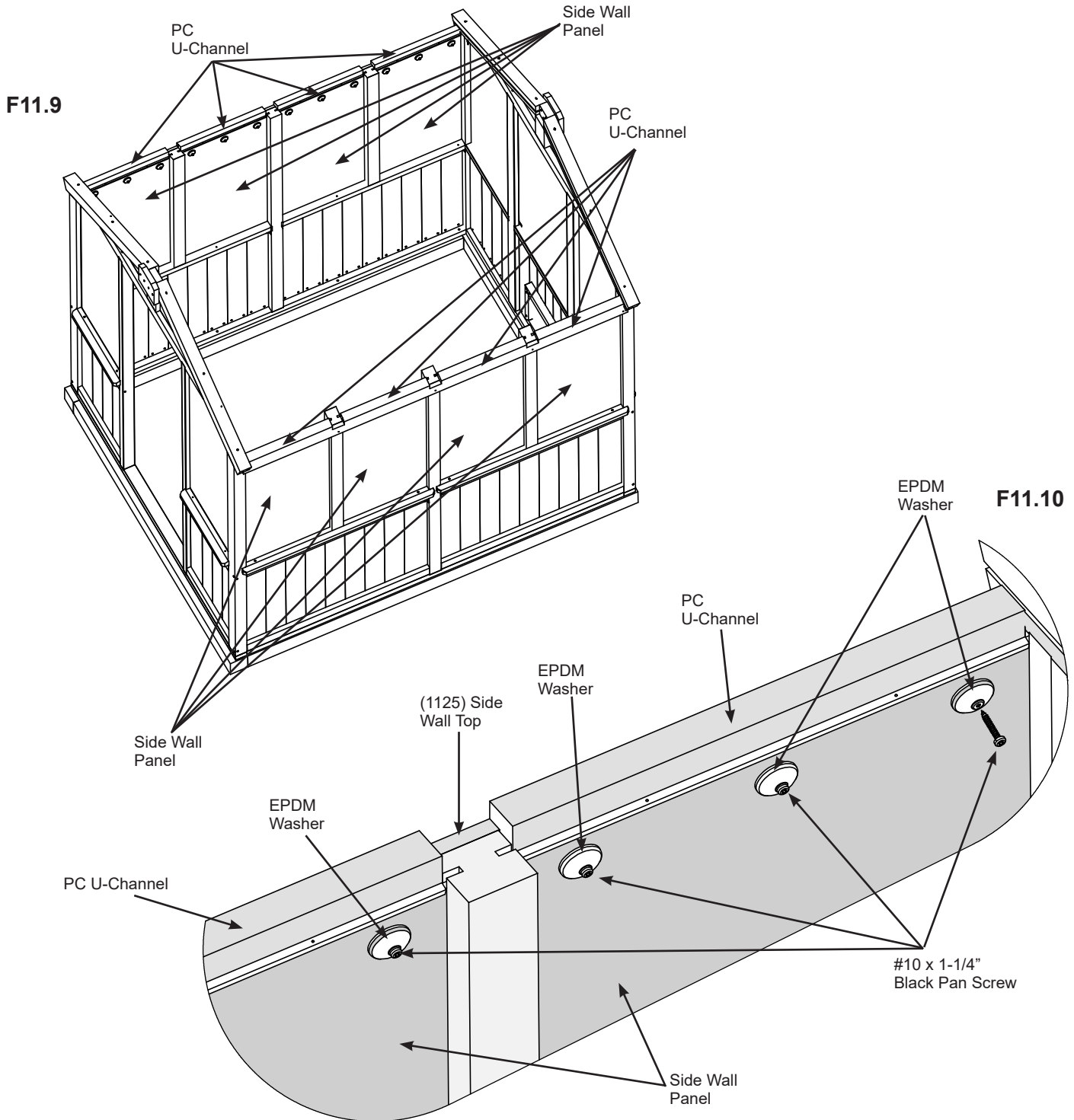

Components

8 x PC U-Channel

Hardware

24 x #10 x 1-1/4" Black Pan Screw

24 x EPDM Washer

Step 12: Roof Peak Assembly Part 1

A: Place three (1114) Middle Roof Rafters in the notches of (1123) Roof Peak. Angled end of rafters tight to (1123) Roof Peak. Groove of (1123) Roof Peak is towards the top of the board and grooves in (1114) Middle Roof Rafters face the sides and should line up with grooves in (1123) Roof Peak. Use (1188) Guide Spacers in grooves of (1123) Roof Peak and (1114) Middle Roof Rafter for accurate positioning then attach with two #8 x 3" Wood Screws per rafter. Remove (1188) Guide Spacers (F12.1 and F12.2)

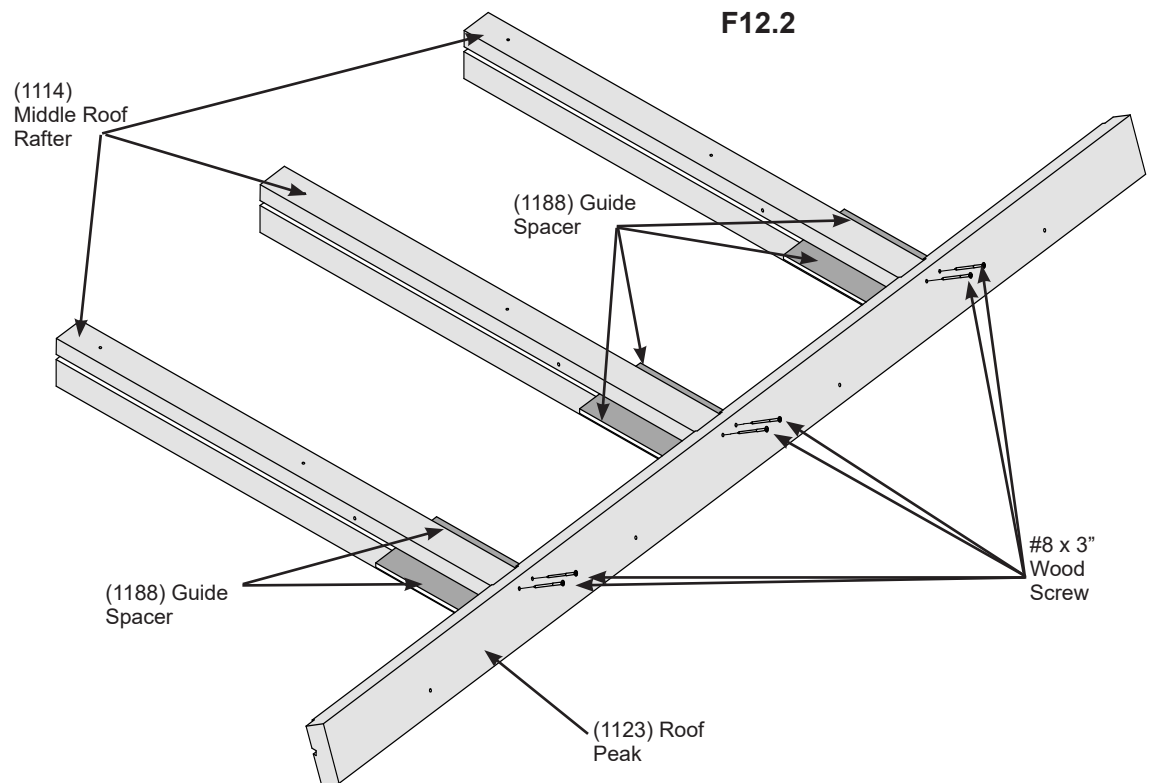
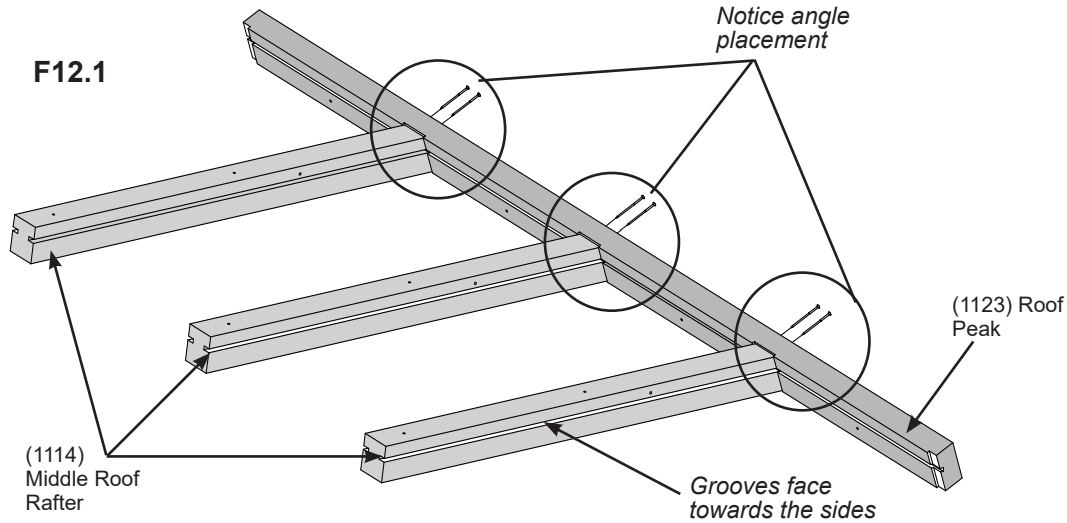

Wood Parts

3 x (1114) Middle Roof Rafter
1 x (1123) Roof Peak

Hardware

6 x #8 x 3" Wood Screw

Step 12: Roof Peak Assembly Part 2

B: Flip the assembly over then attach each (1114) Middle Roof Rafter to (1123) Roof Peak with one #10 x 4" Wood Screw per rafter. Screws are installed at an angle. (F12.3)

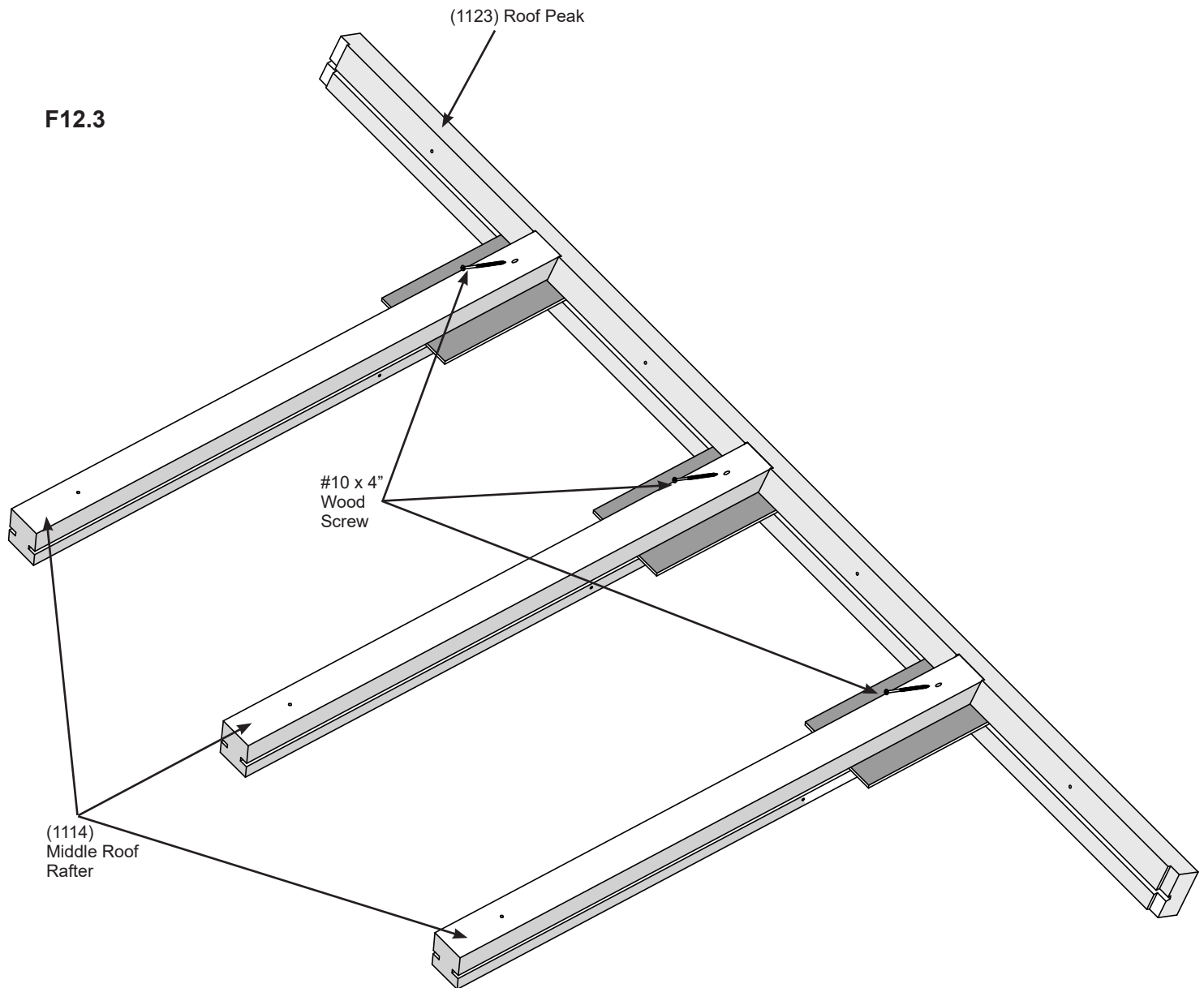

Hardware

3 x #10 x 4" Wood Screw

Step 13: Vent Roof Peak Assembly Part 1

A: Place two (1114) Middle Roof Rafters in notches of (1124) Vent Roof Peak. Angled end of rafters tight to (1124) Vent Roof Peak. Groove of (1124) Vent Roof Peak is towards the top of the board and grooves in (1114) Middle Roof Rafters face the sides and should line up with the groove in (1124) Vent Roof Peak. Use (1188) Guide Spacers in grooves of (1124) Vent Roof Peak and (1114) Middle Roof Rafter for accurate positioning then attach with two #8 x 3" Wood Screws per rafter. Remove (1188) Guide Spacers. (F13.1)

B: Flip the assembly over then attach each (1114) Middle Roof Rafter to (1124) Vent Roof Peak with one #10 x 4" Wood Screw per rafter. Screws are installed at an angle. (F13.2)

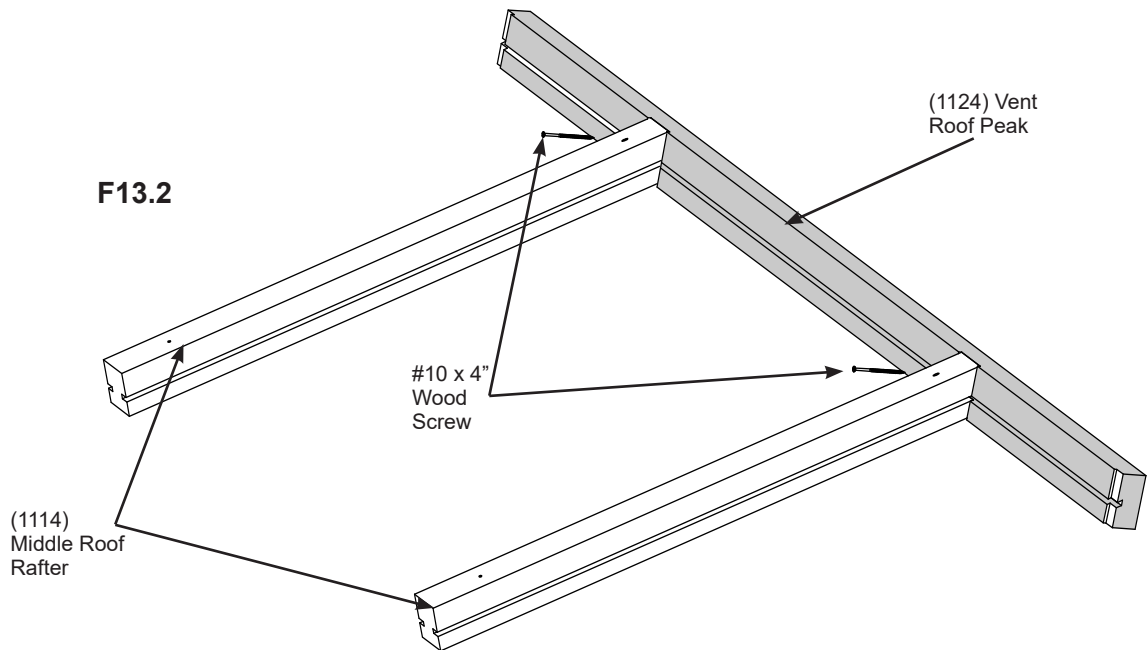
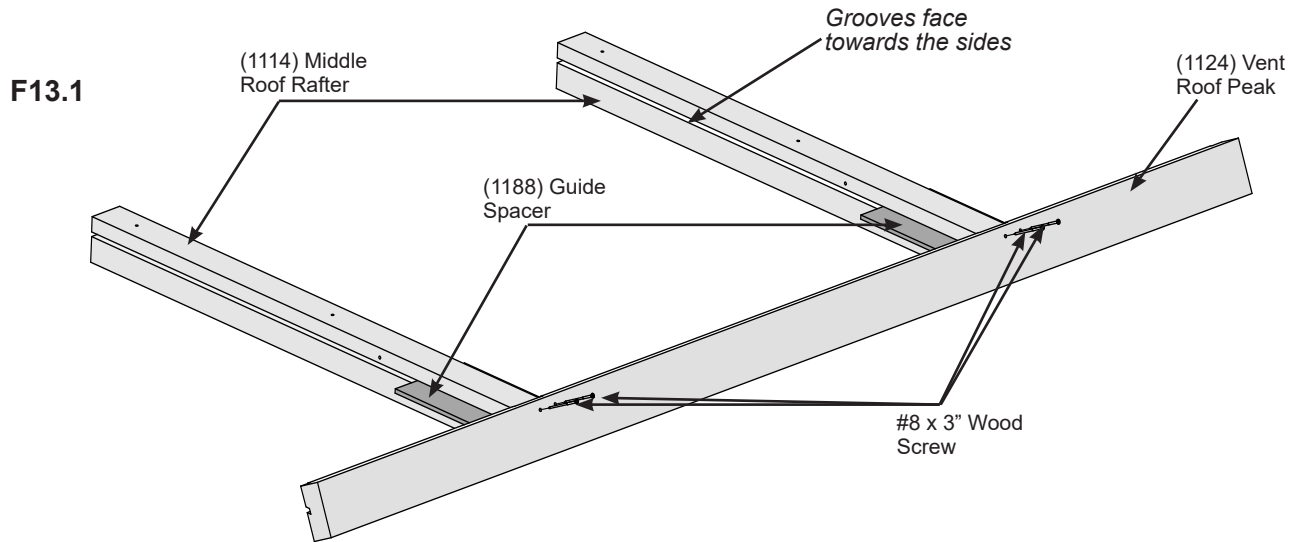

Wood Parts

- 2 x (1114) Middle Roof Rafter
- 1 x (1124) Vent Roof Peak

Hardware

- 4 x #8 x 3" Wood Screw
- 2 x #10 x 4" Wood Screw

Step 13: Vent Roof Peak Assembly Part 2

C: Flip the assembly over then on the inside of each (1114) Middle Roof Rafter, place one (1126) Inside Vent Block with angled end tight to the top of (1124) Vent Roof Peak and sides flush to the top of each rafter. Attach (1126) Inside Vent Block to (1114) Middle Roof Rafters with three #8 x 2" Wood Screws per block. (F13.3 and F13.4)

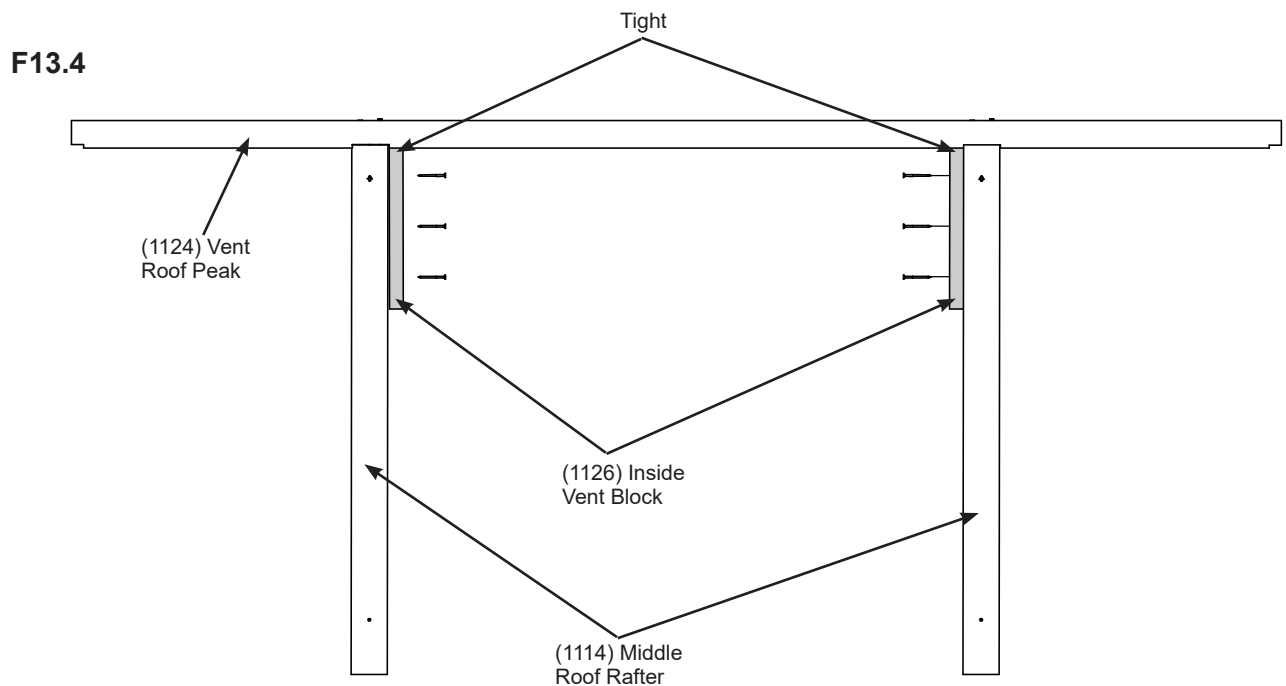
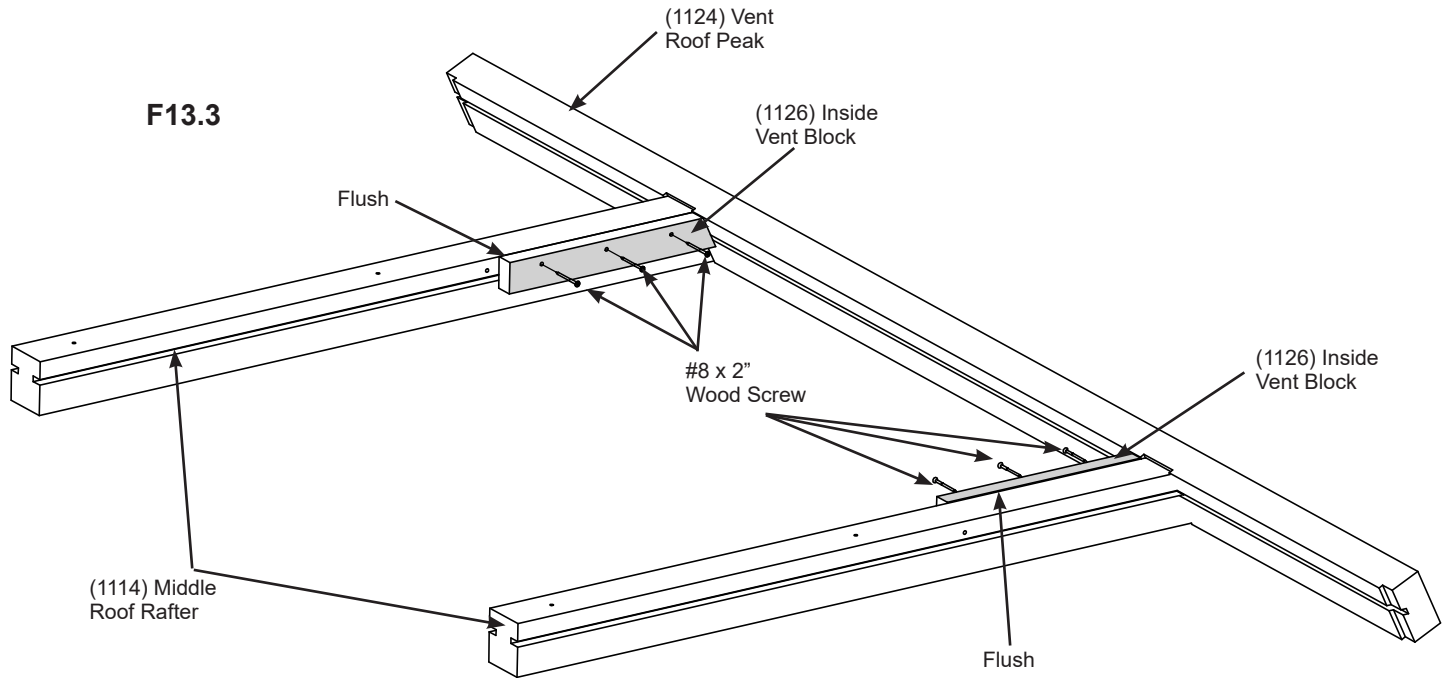

Wood Parts

2 x (1126) Inside Vent Block

Hardware

6 x #8 x 2" Wood Screw

Step 13: Vent Roof Peak Assembly Part 3

D: Tight to the top of (1126) Inside Vent Blocks, with grooves facing down, place (1128) Bottom Vent Block. Use (1188) Guide Spacers in grooves of (1114) Middle Roof Rafters and (1128) Bottom Vent Block for accurate positioning then attach rafters to block with one #10 x 4" Wood Screw per rafter. Remove (1188) Guide Spacers. (F13.5 and F13.6)

F13.5

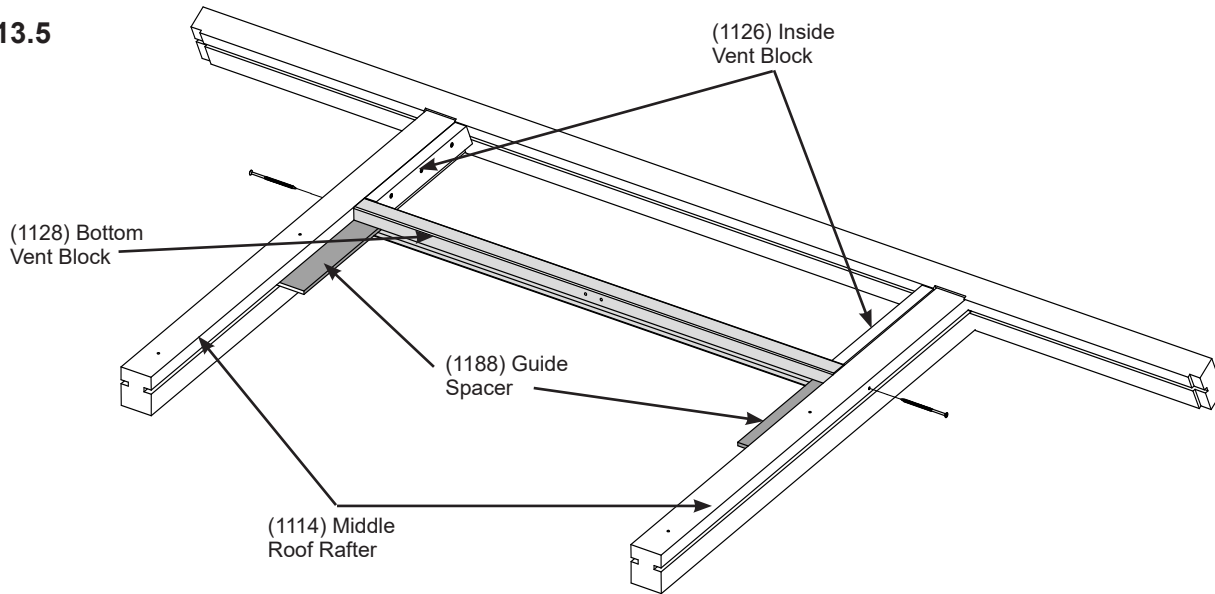

F13.6

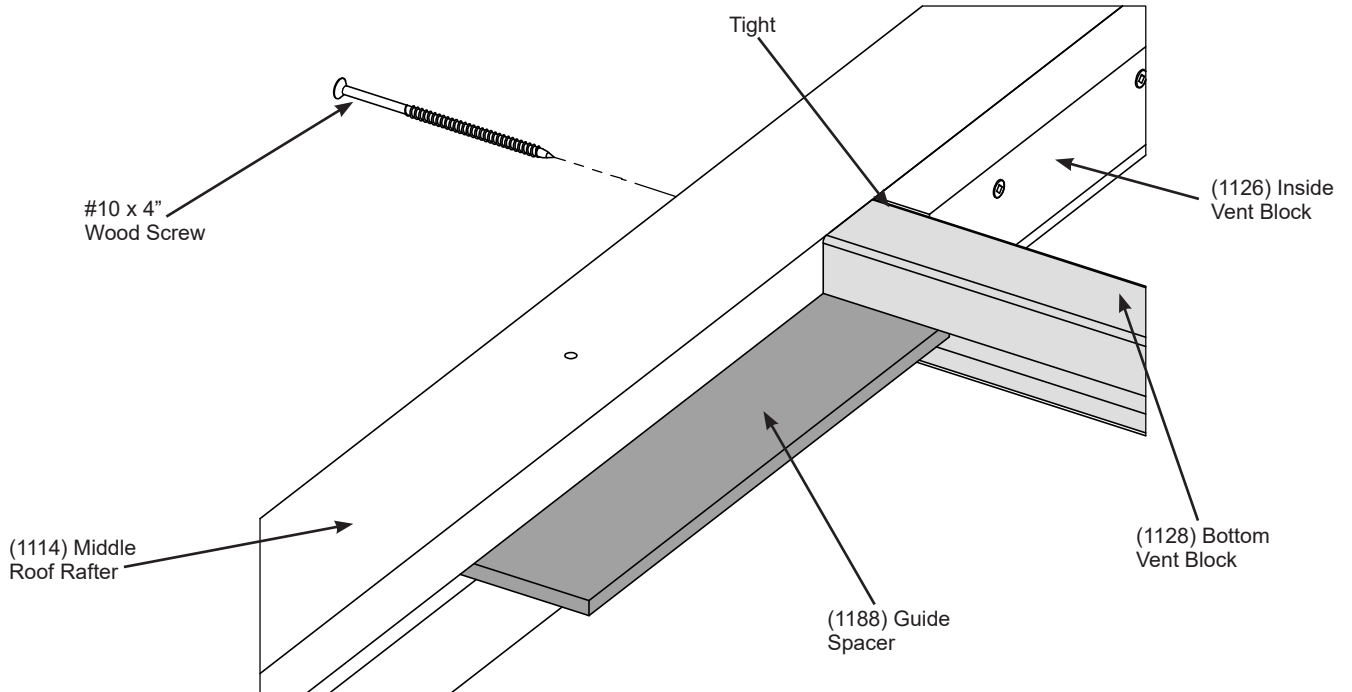

Wood Parts

1 x (1128) Bottom Vent Block

Hardware

2 x #10 x 4" Wood Screw

Step 13: Vent Roof Peak Assembly Part 4

E: On the bottom of the (1170) Vent Roof Panel, flush to the bottom board and centred on the panel, attach (1187) Vent Roof Panel Block with three #8 x 1-1/4" Wood Screws. (F13.7 and F13.8)

F13.7

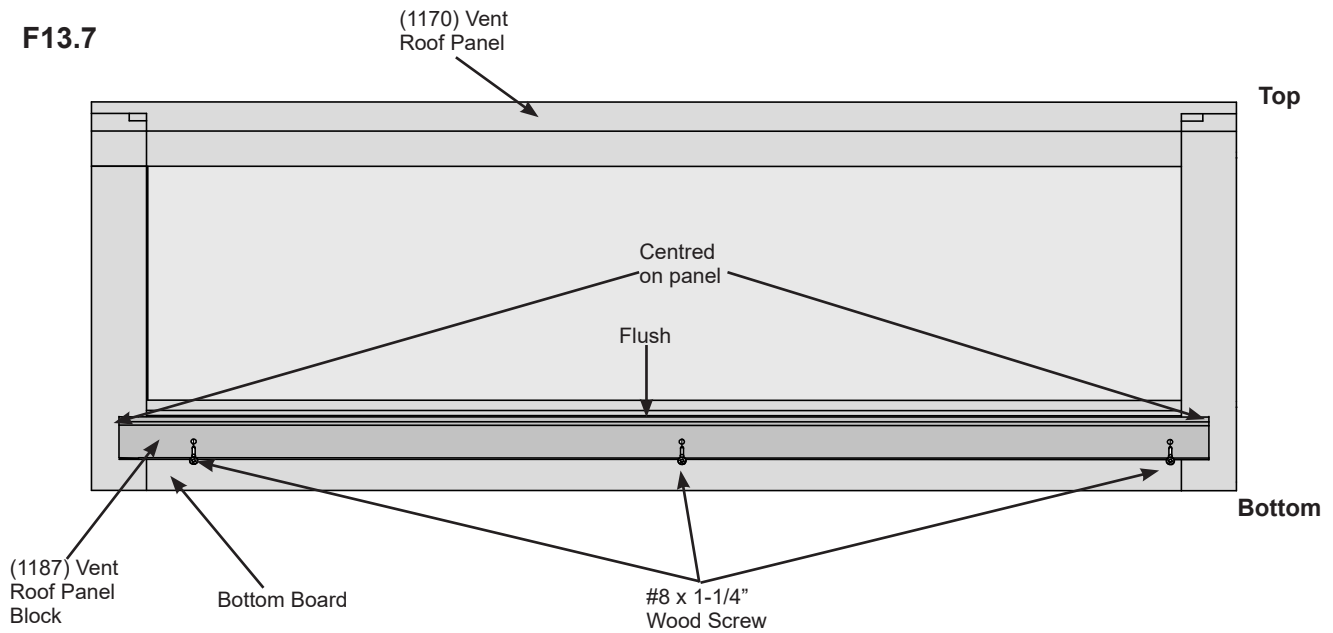

Notice angle orientation and at top

F13.8

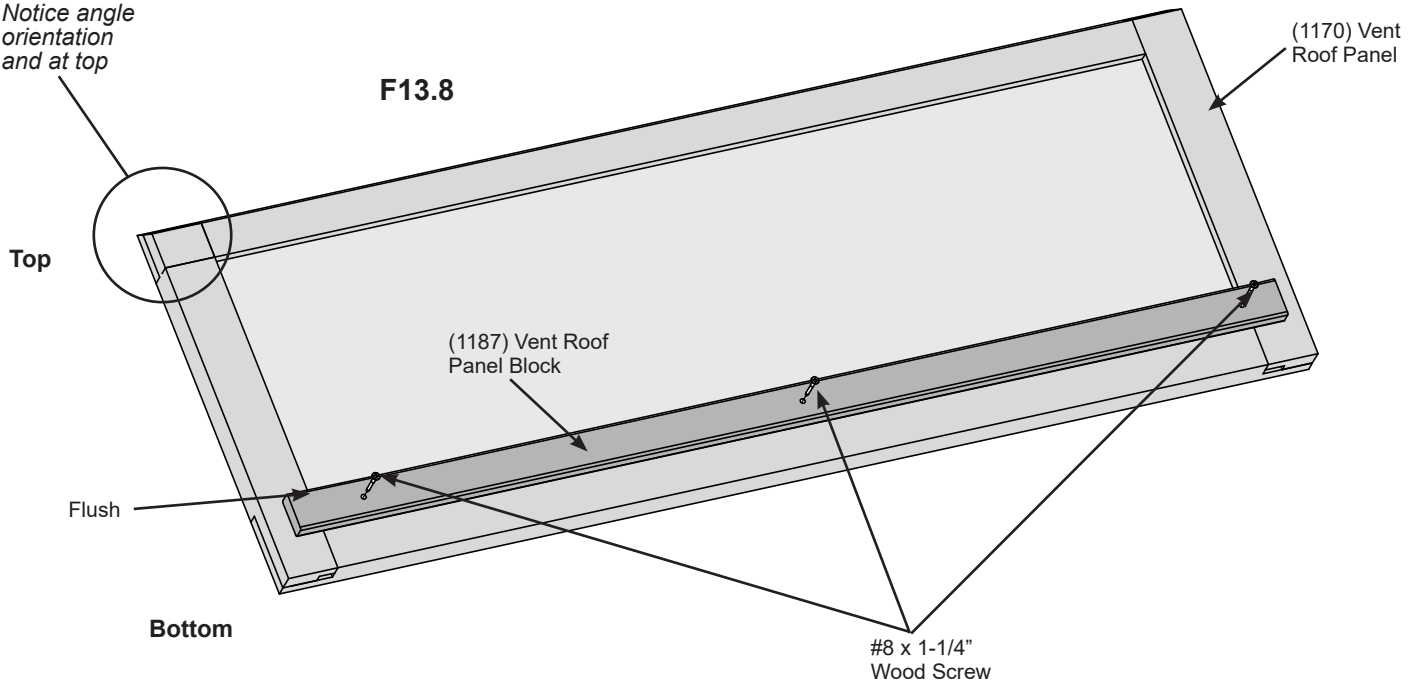

Wood Parts

- 1 x (1170) Vent Roof Panel
- 1 x (1187) Vent Roof Panel Block

Hardware

- 3 x #8 x 1-1/4" Wood Screw

Step 13: Vent Roof Peak Assembly Part 5

F: Flip over Vent Roof Peak Assembly and place (1170) Vent Roof Panel, with angled edge on top, over (1126) Inside Vent Blocks and (1128) Bottom Vent Block and tight to (1124) Vent Roof Peak. (1187) Vent Roof Panel Block faces down. (F13.9)

G: Place Continuous Hinge on (1124) Vent Roof Peak and (1170) Vent Roof Panel and attach with 34 #8 x 1/2" Pan Screws. Do not install screws at the end of the hinge on (1170) Vent Roof Panel. **Note: Keep drill perpendicular when installing screws.** (F13.9, F13.10, F13.11 and F13.12)

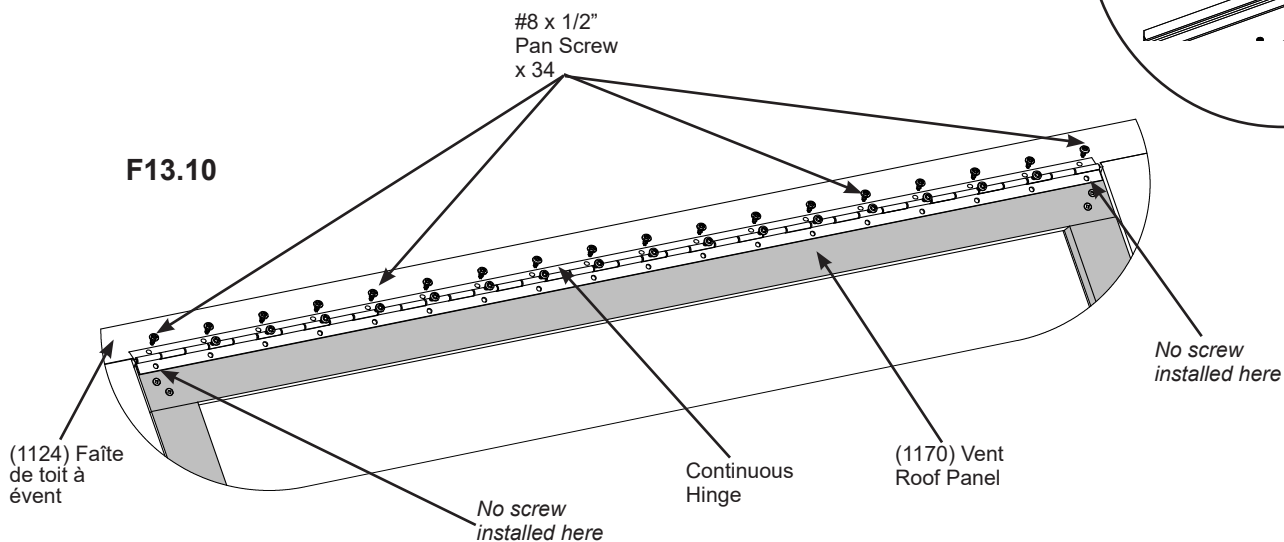
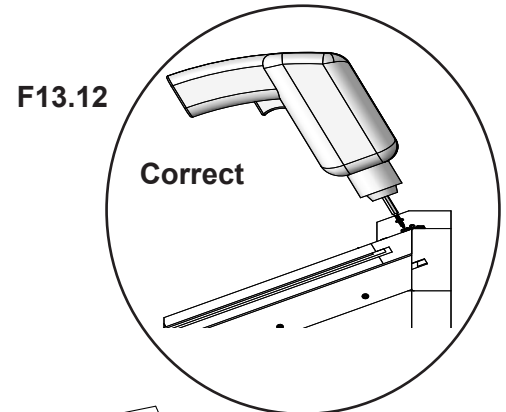
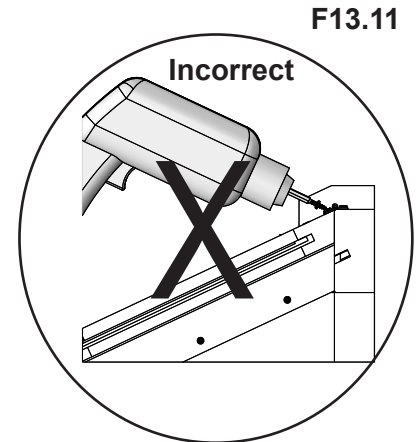
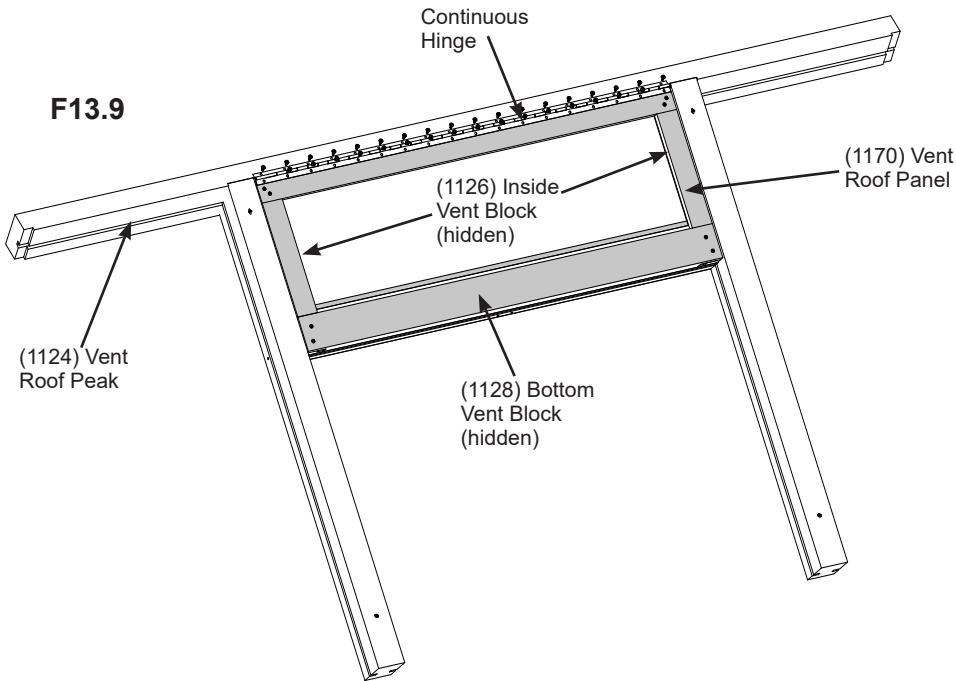

Components

1 x Continuous Hinge

Hardware

34 x #8 x 1/2" Pan Screw

Step 14: Attach Roof Assemblies to Frame Part 1



A: With adult helpers lift Vent Roof Peak Assembly over frame and place (1124) Vent Roof Peak on (1121) Upright Insides, tight to (1184) Peak Spacer, (1115) Right Roof Rafter and (1116) Left Roof Rafter. (1114) Middle Roof Rafters sit in notches of (1125) Side Wall Top. Have one person hold assembly in place until secure. (F14.1 and F14.2)

B: Repeat Step A for Roof Peak Assembly. (1123) Roof Peak placed on (1121) Upright Insides, tight to (1184) Peak Spacer, (1115) Right Roof Rafter and (1116) Left Roof Rafter. (F14.3 and F14.4)

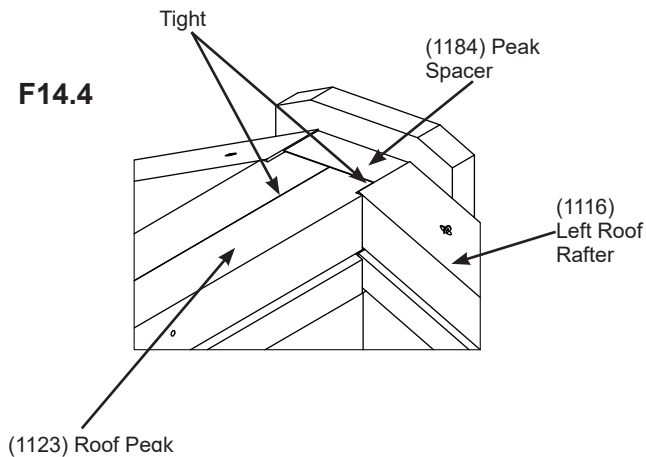
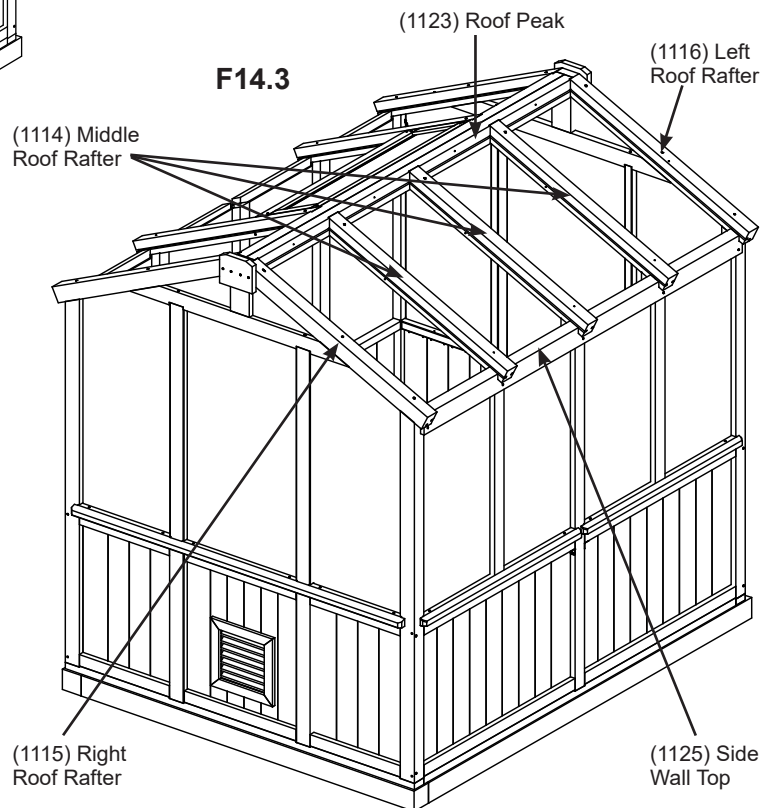
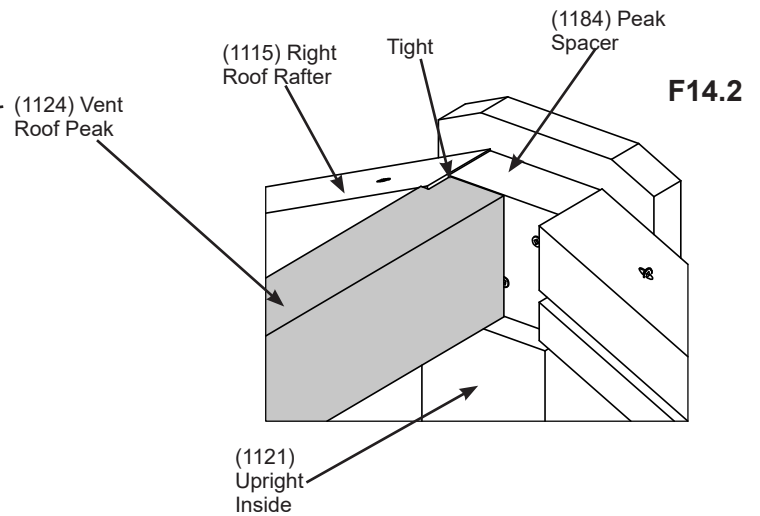
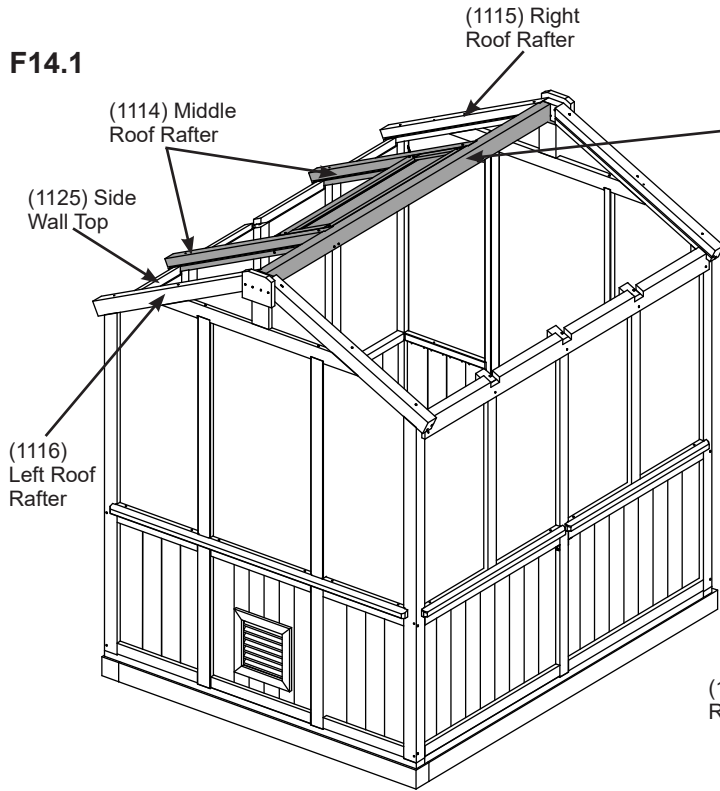

Step 14: Attach Roof Assemblies to Frame Part 2



Use (1188) Guide Spacer to make sure grooves in Peak Assemblies are lined up with grooves in Rafters.

C: Secure Roof Peak Assembly to Vent Roof Peak Assembly with four #8 x 3" Wood Screws. (F14.5 and F14.6)

D: Connect each (1184) Peak Spacer to (1123) Roof Peak and (1124) Vent Roof Peak with two #10 x 4" Wood Screws per end. (F14.7 and F14.8)

F14.5

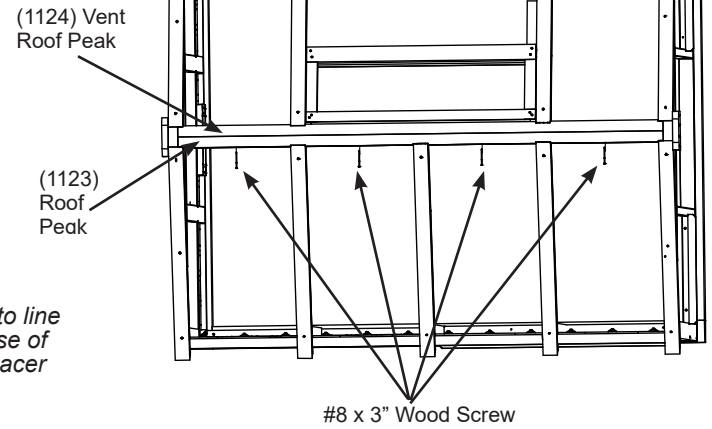

F14.6

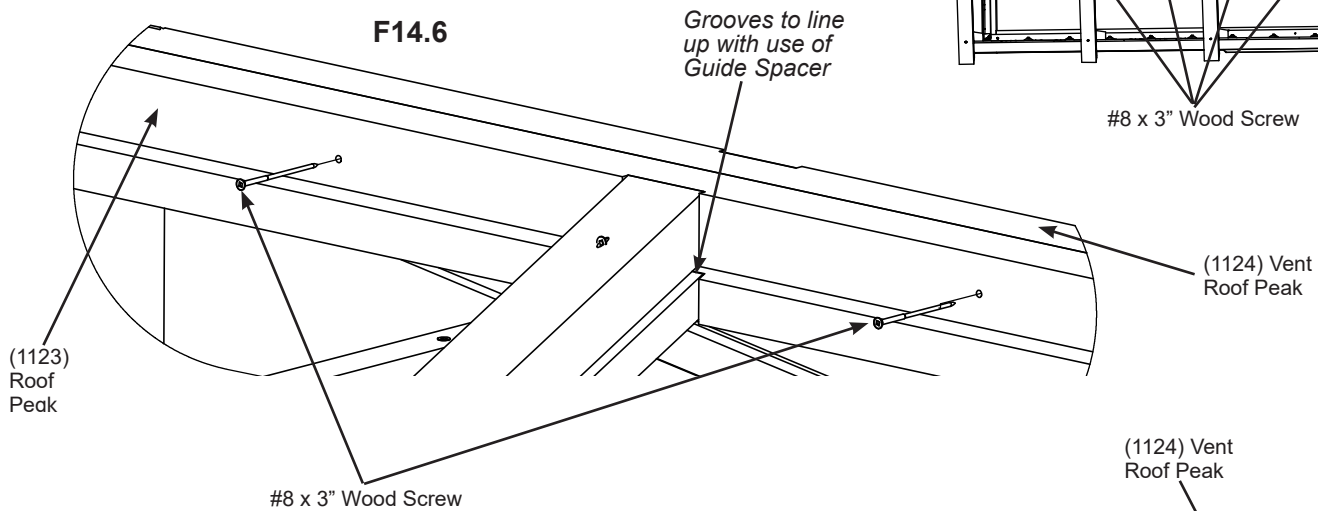

F14.7

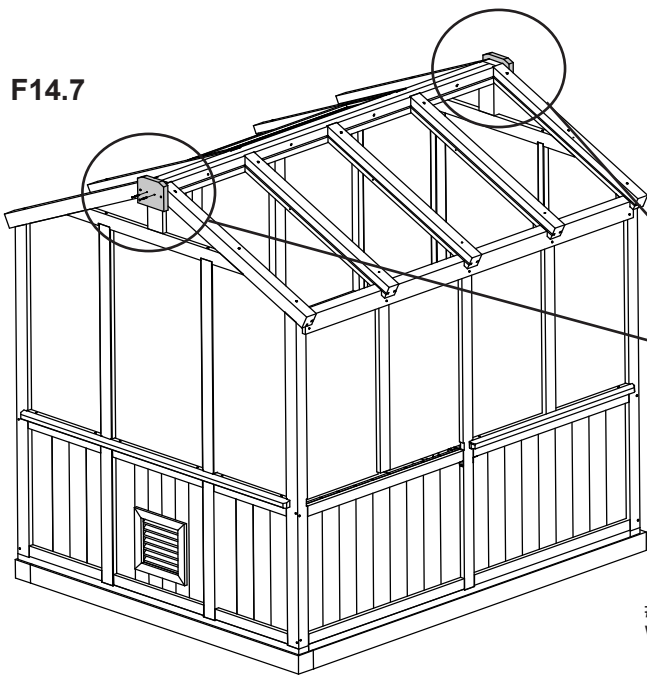

F14.8

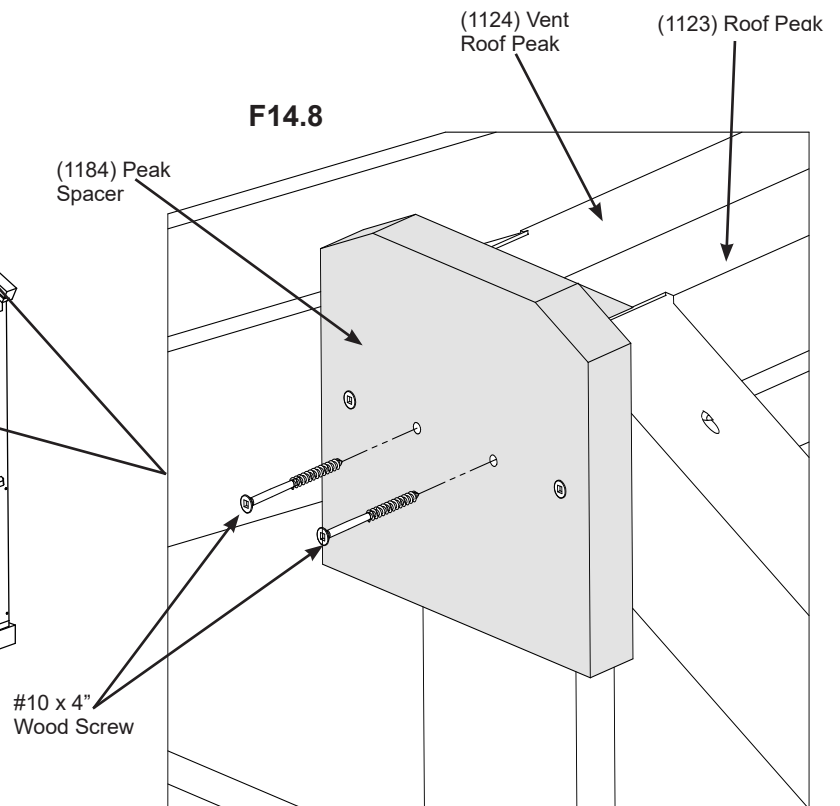

Hardware

- 4 x #8 x 3" Wood Screw
- 4 x #10 x 4" Wood Screw

Step 14: Attach Roof Assemblies to Frame Part 3



E: Apply silicone sealant at top of assembly where (1123) Roof Peak and (1124) Vent Roof Peak join. Sealant should be applied in small beads and smoothed out. (F14.9 and F14.10)

F: Apply silicone caulking on the top of the Continuous Hinge so the silicone completely covers the pivot joints. (F14.11)

Note: All surfaces to be clean, dry, dust and grease free before application with temperatures above 5°C (41°F), no warmer than 35°C (95°F).

- Cut off tip of tube, attach supplied nozzle then put in caulking gun. See page 6.
- Apply sealant in small beads and smooth as required.
- Clean excess with a cloth or paper towel before it skins over.
- Always wear safety glasses and rubber gloves when using product.

See page 6 for Warning and First Aid Information.

F14.9

(1123) Roof Peak

(1124) Vent Roof Peak

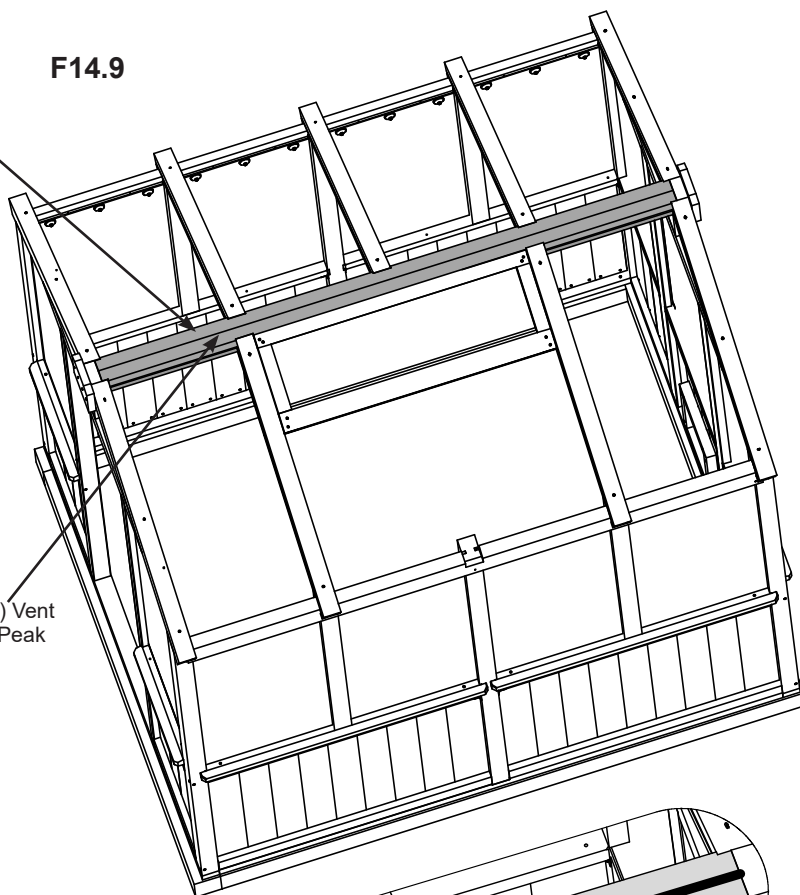

F14.10

(1123) Roof Peak

Sealant

(1124) Vent Roof Peak

F14.11

Sealant

Continuous Hinges

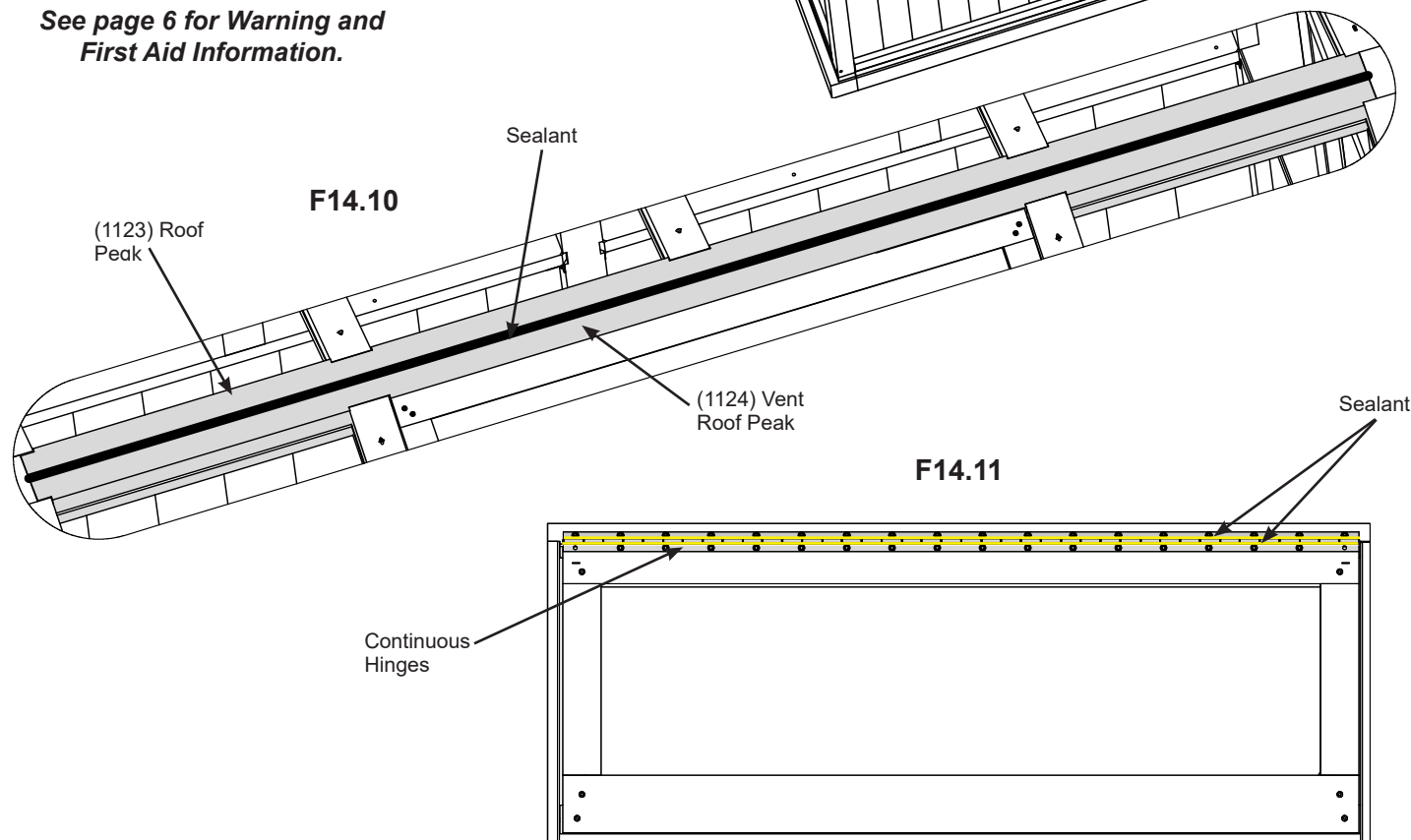

Components

Sealant

Step 14: Attach Roof Assemblies to Frame Part 4

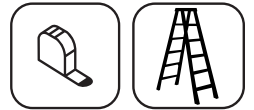

G: Make sure each (1114) Middle Roof Rafter overhangs (1125) Side Wall Tops by 3/4" (1.91 cm). Secure (1114) Middle Roof Rafters to (1110) Mid Posts and (1144) Short Post Assemblies with one #10 x 5-5/8" Wood Screw per rafter. (F14.12 and F14.13)

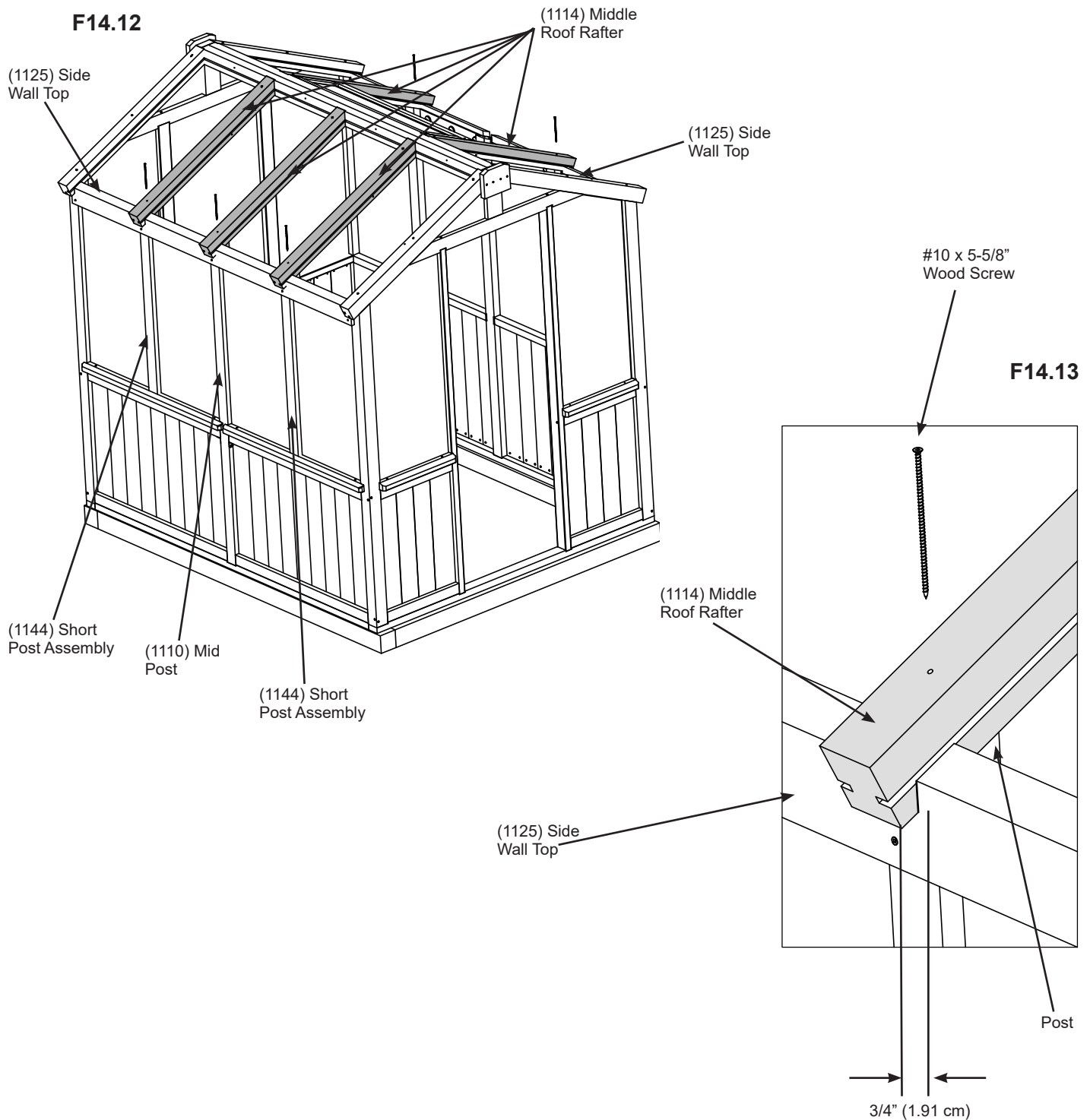

Hardware

5 x #10 x 5-5/8" Wood Screw

Step 15: Attach Vent Roof Rafter

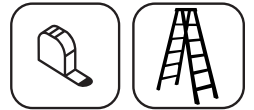

A: Place (1127) Vent Roof Rafter tight to (1128) Bottom Vent Block so it fits in the remaining notch of (1125) Side Wall Top. Use (1188) Guide Spacers in grooves of (1128) Bottom Vent Block and (1127) Vent Roof Rafter for accurate positioning then attach (1128) Bottom Vent Block to (1127) Vent Roof Rafter with two #8 x 3" Wood Screws. Remove (1188) Guide Spacers. The distance between rafter will be 19-9/16" (49.69 cm). (F15.1, F15.2 and F15.3)

B: Make sure (1127) Vent Roof Rafter overhangs (1125) Side Wall Top by 3/4" (1.91 cm) then attach to (1110) Mid Posts with one #10 x 5-5/8" Wood Screw. (F15.1 and F15.4)

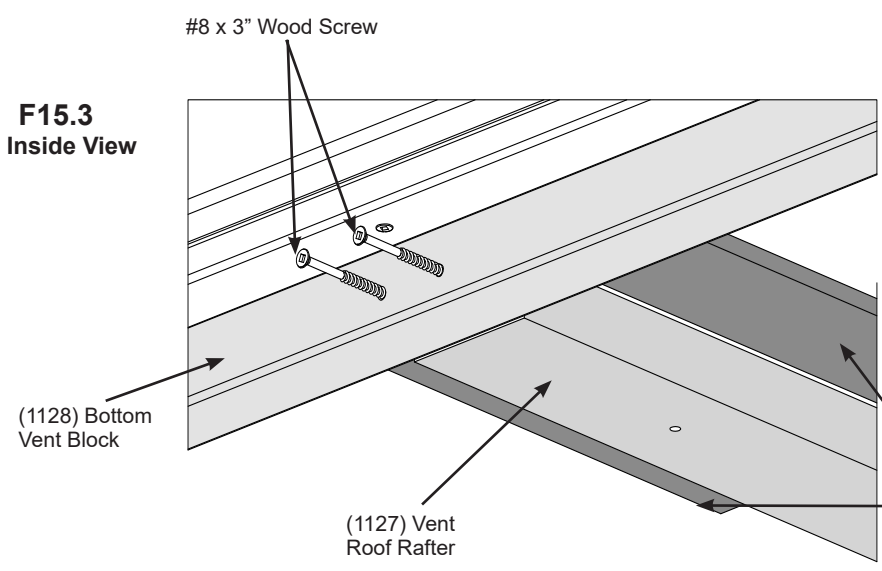
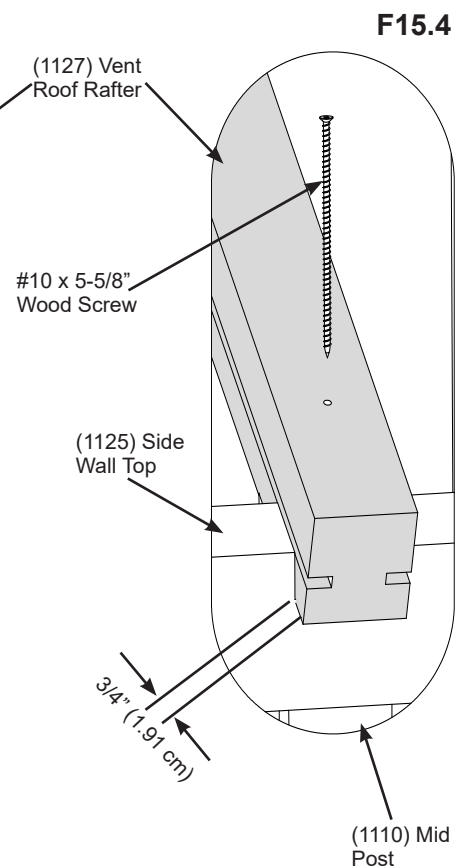
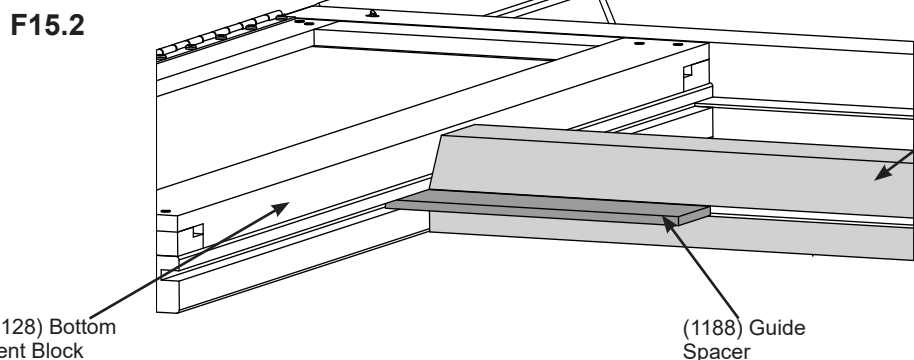
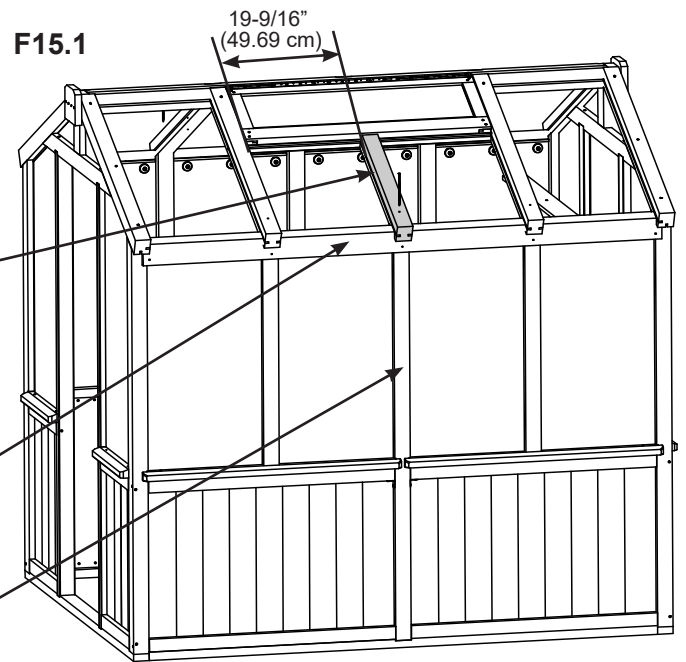

Wood Parts

1 x (1127) Vent Roof Rafter

Hardware

2 x #8 x 3" Wood Screw
1 x #10 x 5-5/8" Wood Screw

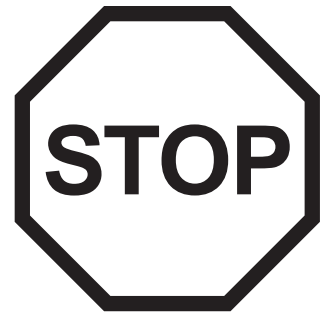
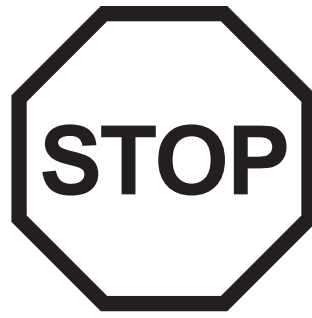
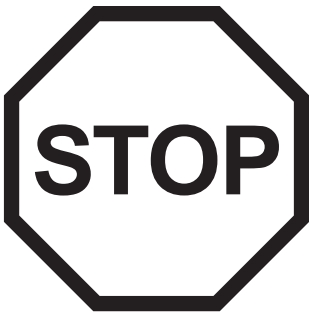

IMPORTANT! SINGLE SPRING WINDOW OPENER INFORMATION

- **The Aluminum Single Spring Window Opener is designed to automatically open and close with changes in temperature. It must not be opened or closed manually. Doing so will result in damage to the component.**
- To change the opening temperature of the component:
 - One complete clockwise turn of the black cylinder will increase the opening temperature of the component by $0.5^{\circ}\text{C}/1^{\circ}\text{F}$
 - One counterclockwise turn will decrease the opening temperature of the component by $0.5^{\circ}\text{C}/1^{\circ}\text{F}$
- The opening temperature of this component can be set to open in temperatures between $16^{\circ}\text{C}/60^{\circ}\text{F}$ and $25^{\circ}\text{C}/77^{\circ}\text{F}$
- The black cylinder is the temperature sensitive component. This should never be used as a pry to manually open or close the vent.
- The cylinder must be in the closed position before it can be removed from the component. To remove the cylinder, remove the pin and unscrew the cylinder.

Step 16: Attach Single Spring Window Opener

Part 1

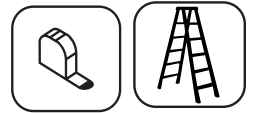

A: The Black Cylinder MUST be in the closed position prior to assembly. To close the cylinder, place it in the refrigerator for 5-7 minutes. After removing from the refrigerator push the Cylinder Rod so it is past the threads 1-1/2" (38.1m). (F16.1)

B: With the cylinder in the closed position screw the Cylinder into the Cylinder Housing halfway. (F16.2)

C: Lift Arm B so the Push Rod aligns with the Cylinder Rod. (F16.3)

D: Lower Arm B so the Cylinder Rod slides into the Push Rod and the holes align. (F16.4)

E: Insert pin in B hole of the Push Rod. (F16.5)

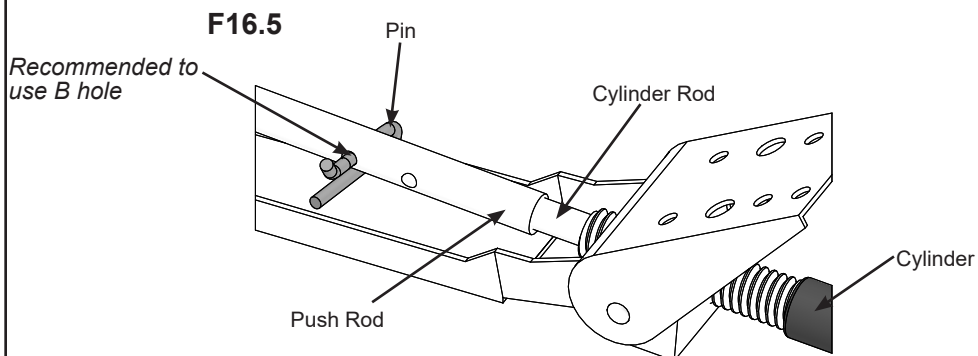
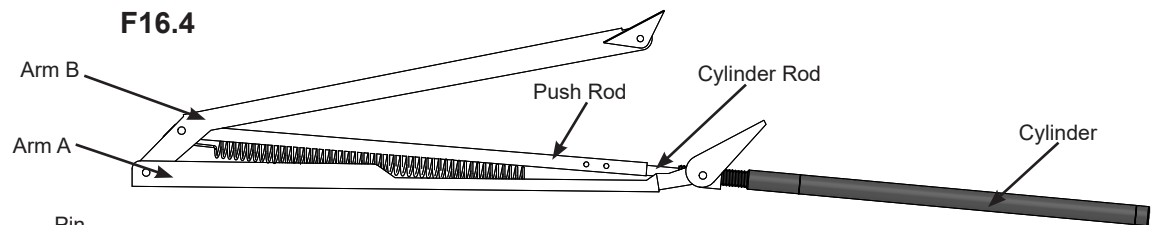
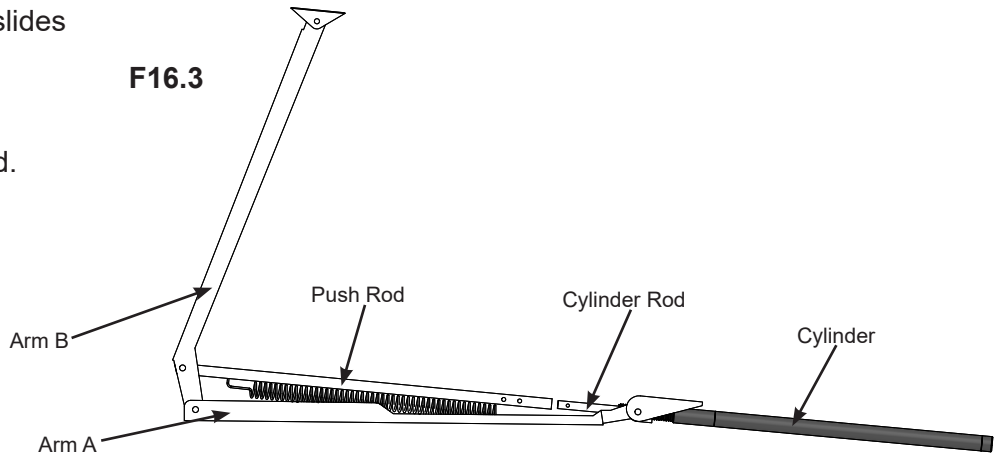
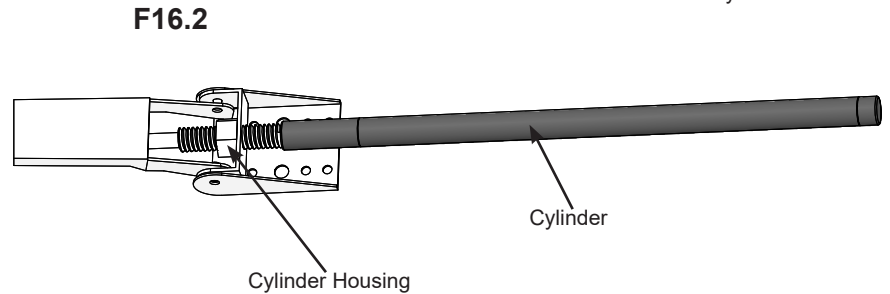
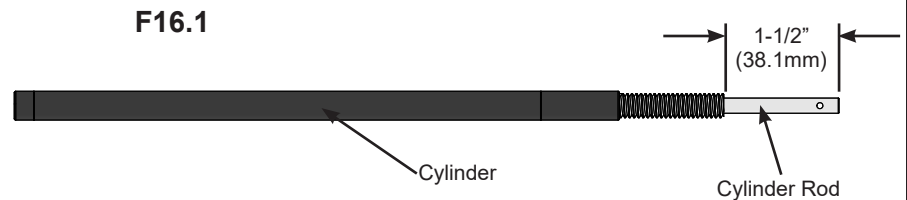

Components

1 x Single Spring Window Opener

Step 16: Attach Single Spring Window Opener



Part 2

F: From inside the assembly, centre Single Spring Window Opener on (1170) Vent Roof Panel so it is aligned with (1127) Vent Roof Rafter. Attach Window Brace A & B to (1187) Vent Roof Panel Block and Frame Bracket to (1128) Bottom Vent Block with two #10 x 1-1/4" Pan Screws per brace. Braces should be in alignment. (F16.6, F16.7, F16.8 and F16.9)

G: The Aluminum Single Spring Window Opener is designed to automatically open and close with changes in temperature. **It must not be opened or closed manually. Doing so will result in damage to the component**

F16.7
Inside View

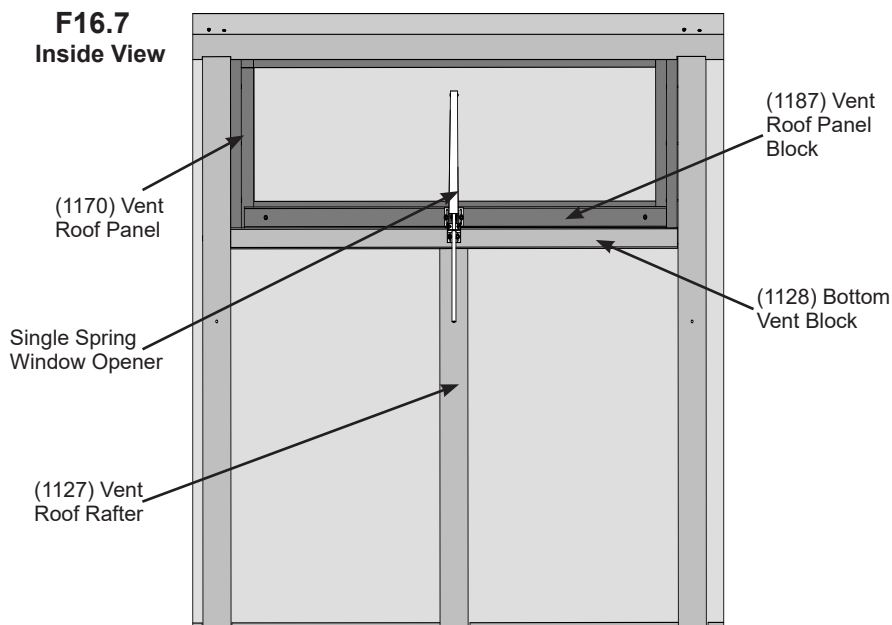

F16.6

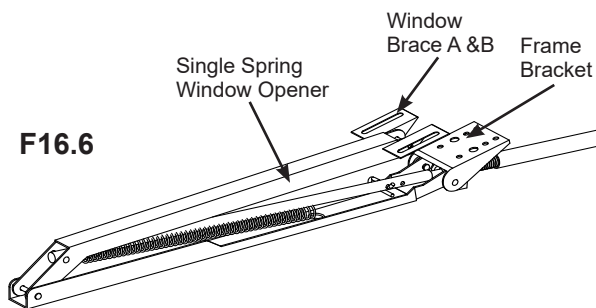

F16.8

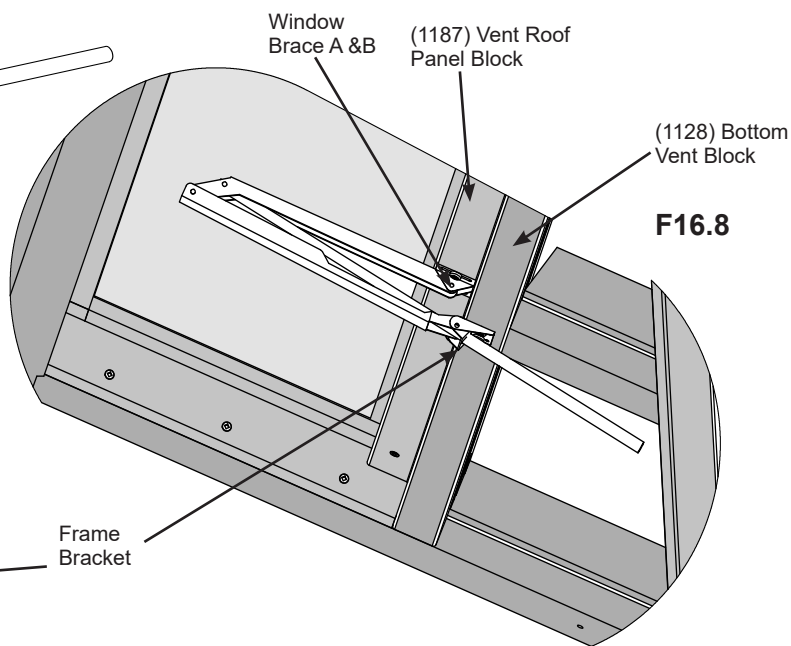

F16.9

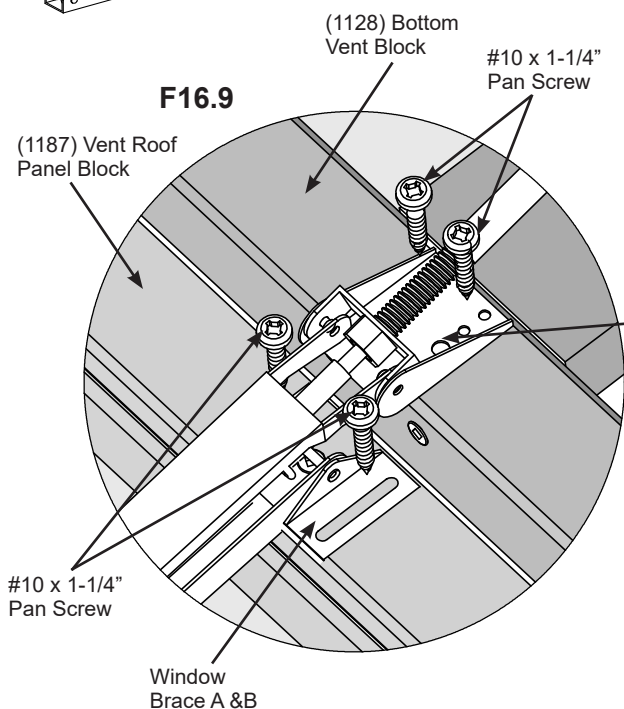

Components

Hardware

4 x #10 x 1-1/4" Pan Screw

Step 17: Install Roof Panels

Part 1



Remove film from both sides of Roof Panels and Small Roof Panels.

A: Refer to pages 16 and 17 and apply top and bottom tape to Roof Panels and Small Roof Panels.

B: On the Side Wall side, in the grooves of Left and Right Roof Rafters and Middle Roof Rafters slide four Roof Panels up to fit in the grooves of (1123) Roof Peak. Make sure the notch at the bottom is always on the right side of the panel. Holes are at the bottom of the panels. The UV coated side must be to the outside of the Assembly. (F17.1)

C: On the Vent Side Wall side, in the grooves of Left and Right Roof Rafters, Middle Roof Rafters and Vent Roof Rafter slide two Roof Panels and two Small Roof Rafter Panels up to fit in the grooves of (1124) Vent Roof Peak and (1128) Bottom Vent Block. Make sure the notch at the bottom is always on the right side of the panel. Holes are at the bottom of the panels. The UV coated side must be to the outside of the Assembly. (F17.2 and F17.3)

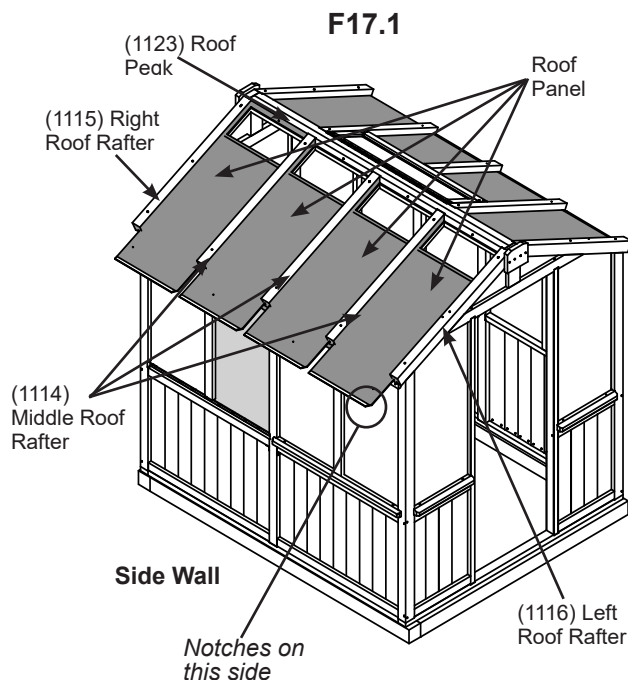

Note: UV Coating to the outside of the frame

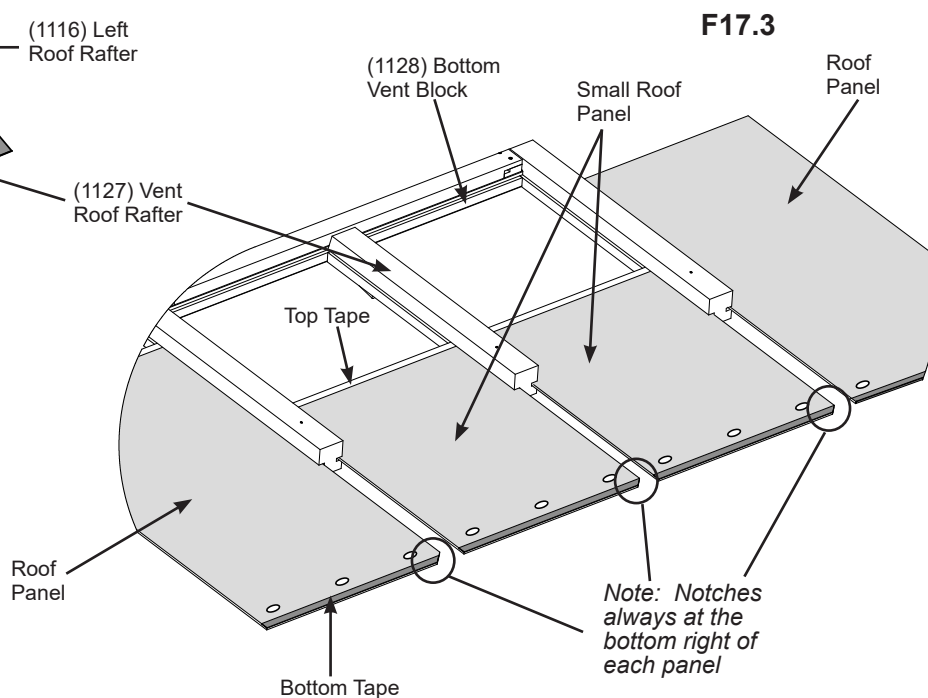
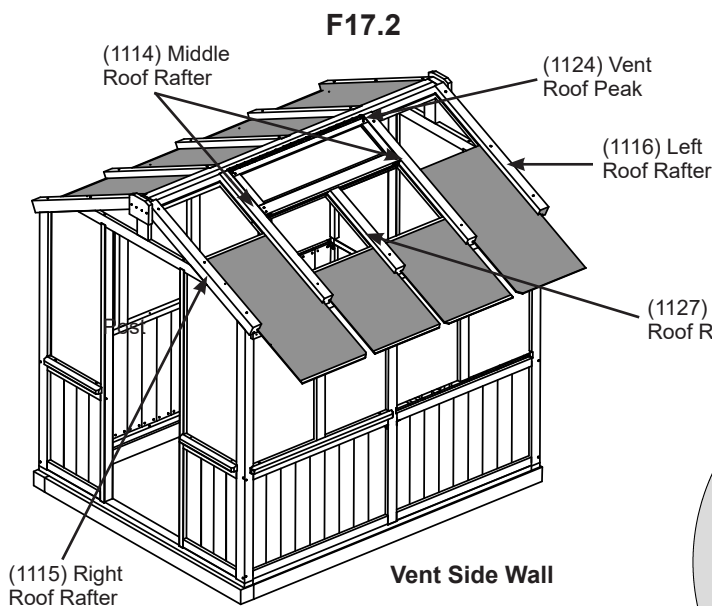

Components

- 6 x Roof Panel
- 2 x Small Roof Panel
- Top Tape
- Bottom Tape

Step 17: Install Roof Panels Part 2

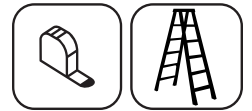

D: On the bottom of each Roof Panel and Small Roof Panel place one PC U-Channel with a gap of approximately 1/8" (3.175 mm) between end of Roof Panel and PC U-Channel. (F17.4, F17.5 and F17.6)

E: Attach bottom of each Roof Panel and Small Roof Panel to (1125) Side Wall Tops using three #10 x 1-1/4" Black Pan Screws with EPDM washers per panel. (F17.7)

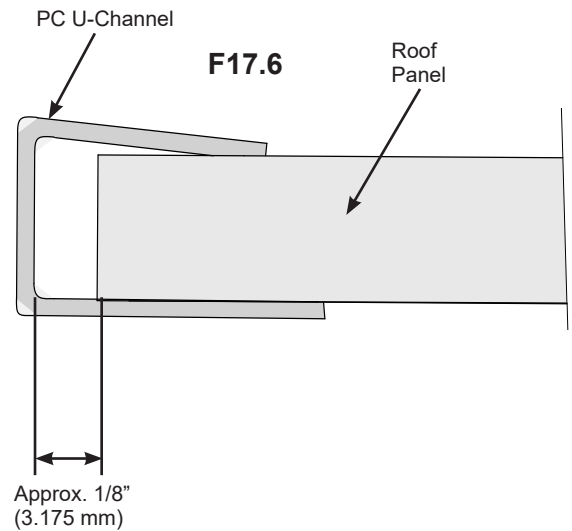
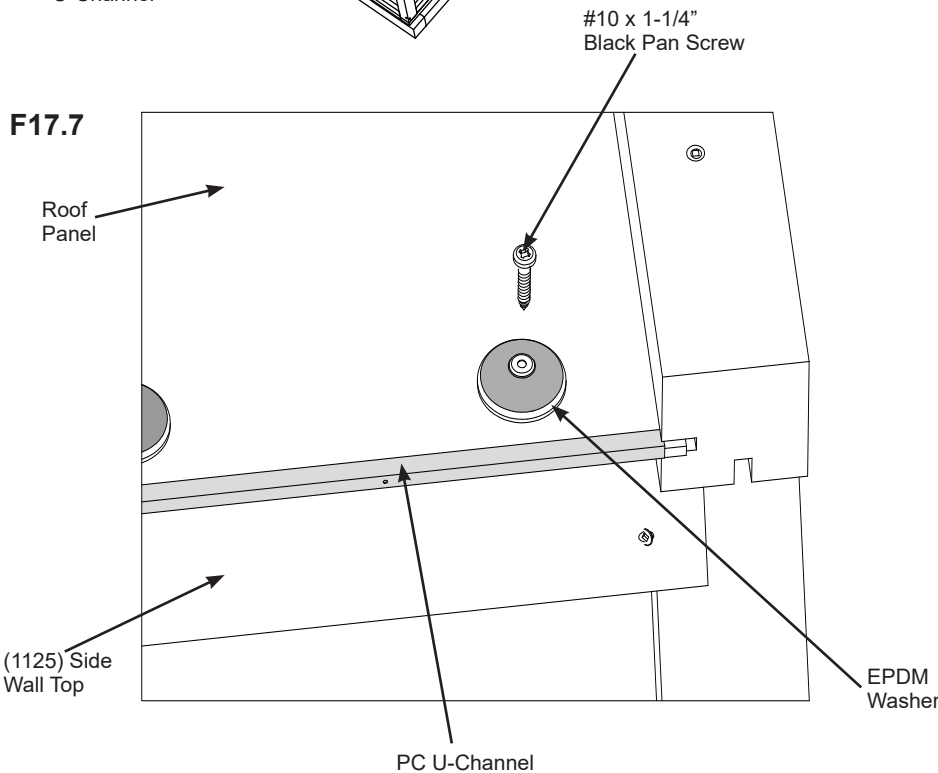
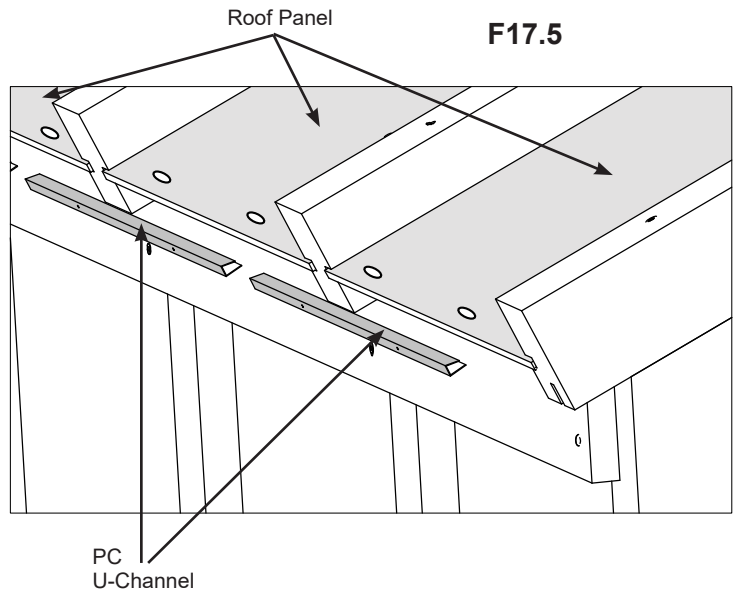
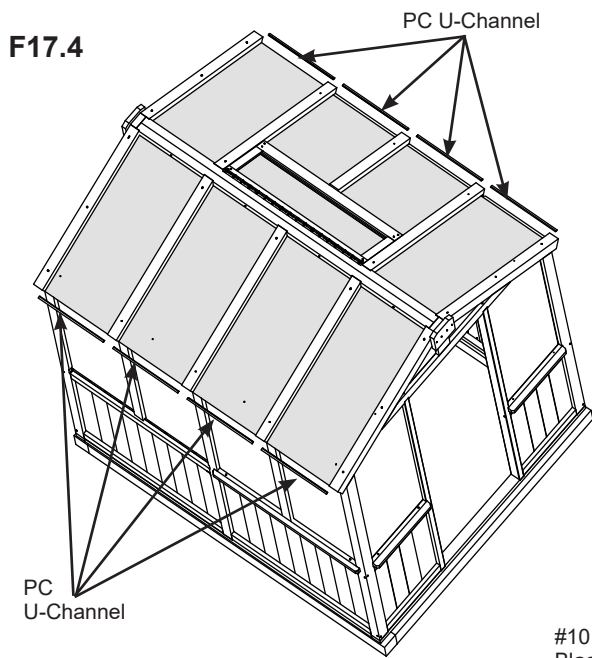

Components

8 x PC U-Channel

Hardware

24 x #10 x 1-1/4" Black Pan Screw
24 x EPDM Washer

Step 18: Apply Sealant Part 1



A: On both the inside and outside of the assembly apply silicone sealant on three sides of each Roof Panel and Small Roof Panel as shown in F18.3. Sealant should be applied in small beads and smoothed out. (F18.1, F18.2 and F18.3)

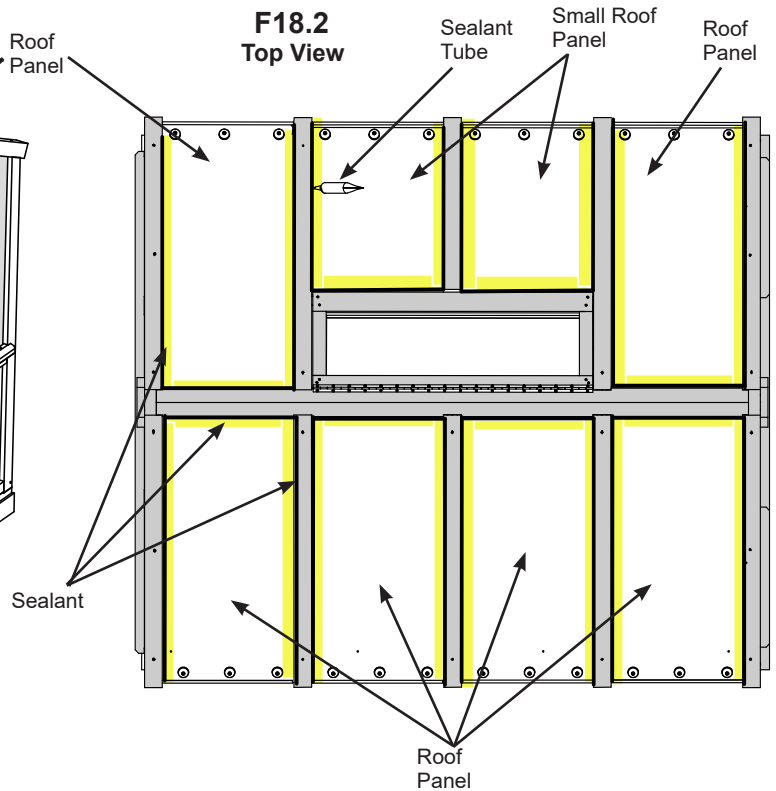
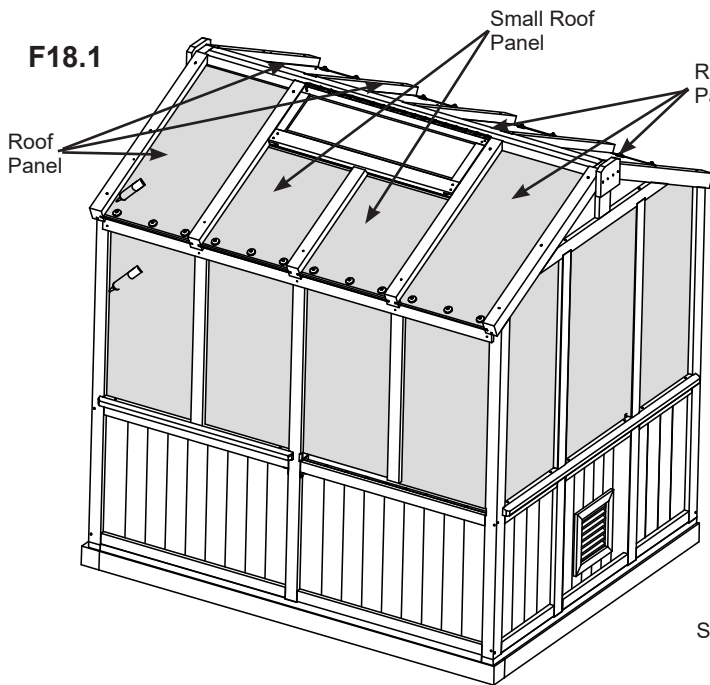

**F18.3
Inside View**

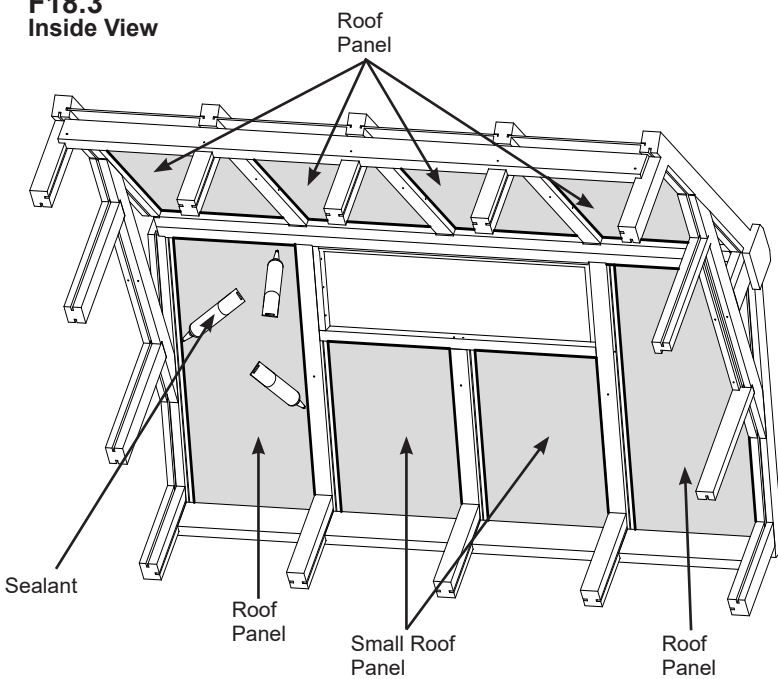

Note: All surfaces to be clean, dry, dust and grease free before application with temperatures above 5°C (41°F), no warmer than 35°C (95°F).

- Cut off tip of tube, attach supplied nozzle then put in caulking gun. See page 6.
- Apply sealant in small beads and smooth as required.
- Clean excess with a cloth or paper towel before it skins over.
- Always wear safety glasses and rubber gloves when using product.

See page 6 for Warning and First Aid Information.

Components

Sealant

Step 18: Apply Sealant Part 2



B: From outside the assembly, on Front Wall, Back Wall and both Side Walls apply silicone sealant on sides and bottom of Left and Right FB Side Panels, Back Centre panel and Side Panels. Sealant should be applied in small beads and smoothed out. (F18.4 and F18.5)

C: From outside the assembly, on Front and Back Walls apply silicone sealant on bottom of Gable Panels. Sealant should be applied in small beads and smoothed out. (F18.4 and F18.6)

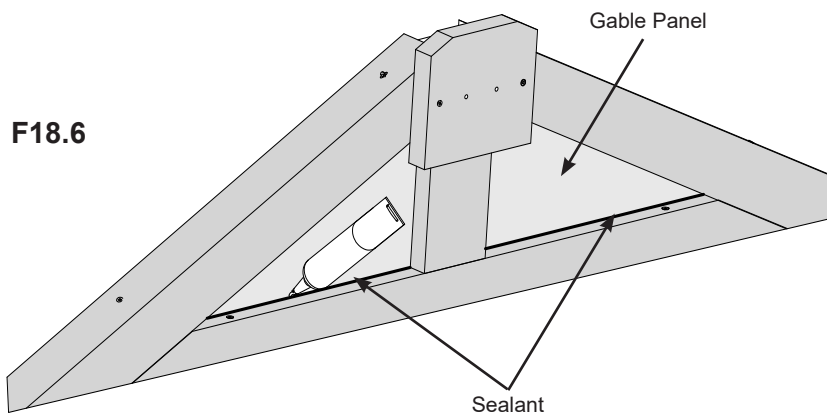
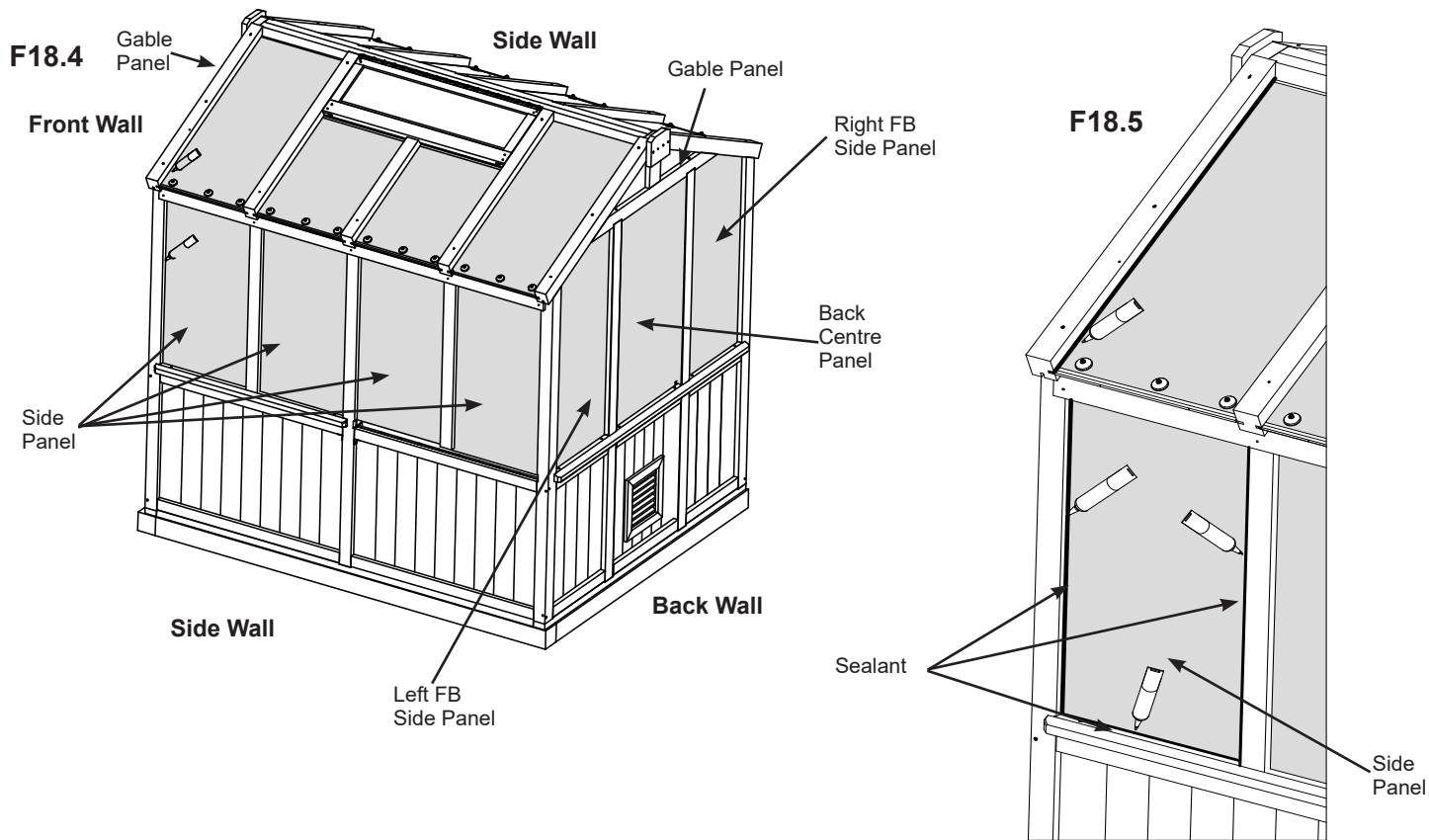

Note: All surfaces to be clean, dry, dust and grease free before application with temperatures above 5°C (41°F), no warmer than 35°C (95°F).

- Cut off tip of tube, attach supplied nozzle then put in caulking gun. See page 6.
- Apply sealant in small beads and smooth as required.
- Clean excess with a cloth or paper towel before it skins over.
- Always wear safety glasses and rubber gloves when using product.

See page 6 for Warning and First Aid Information.

Components

Sealant

Step 18: Apply Sealant Part 3



D: Apply silicone caulking on the top edge of PC U-Channel to seal to Roof and Small Roof Panels. Sealant should be applied in small beads and smoothed out. (F18.7 and F18.8)

F18.7

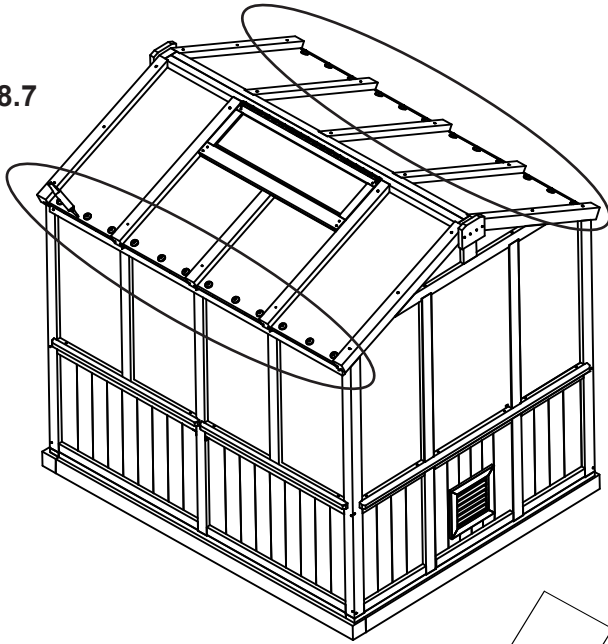

Note: All surfaces to be clean, dry, dust and grease free before application with temperatures above 5°C (41°F), no warmer than 35°C (95°F).

- Cut off tip of tube, attach supplied nozzle then put in caulking gun. See page 6.
- Apply sealant in small beads and smooth as required.
- Clean excess with a cloth or paper towel before it skins over.
- Always wear safety glasses and rubber gloves when using product.

See page 6 for Warning and First Aid Information.

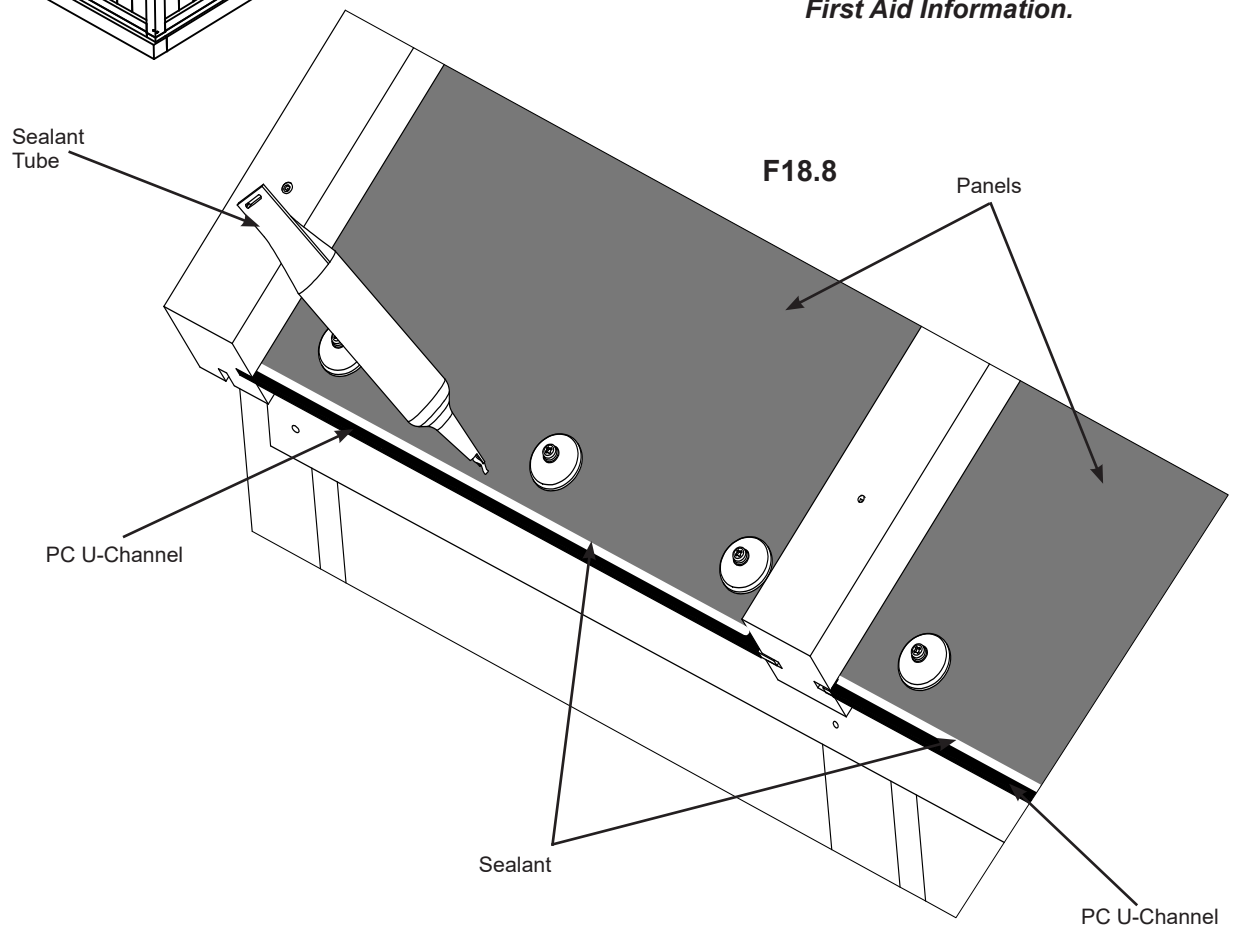

Components

Sealant

Step 19: Upper Shelf Assembly Part 1



Note: Upper and Lower Shelves can be installed on either Side Wall.

A: On the Back Wall, at each post measure 31" (78.74 cm) up from the top of (1106) Back Wall Sill and make a mark. Place one (1138) Wooden Gusset on each post so the top of the gusset is at the measured mark. (1138) Wooden Gusset to be centered on (1113) Back Posts and flush to the inside of (1108) Left Post and (1109) Right Post. Attach Gussets to posts with two #8 x 3" Wood Screws per gusset. (F19.1, F19.2, F19.3 and F19.4)

B: On one Side Wall, at each post measure 31" (78.74 cm) up from the top of (1107) Side Wall Sill and make a mark. Place one (1138) Wooden Gusset on each post so the top of the gusset is at the measured mark. (1138) Wooden Gusset to be centered on (1110) Mid Post and (1144) Short Post Assemblies and flush to the inside of Left or Right Post. Attach Gussets to posts with two #8 x 3" Wood Screws per gusset. (F19.1, F19.2, F19.3 and F19.4)

F19.1

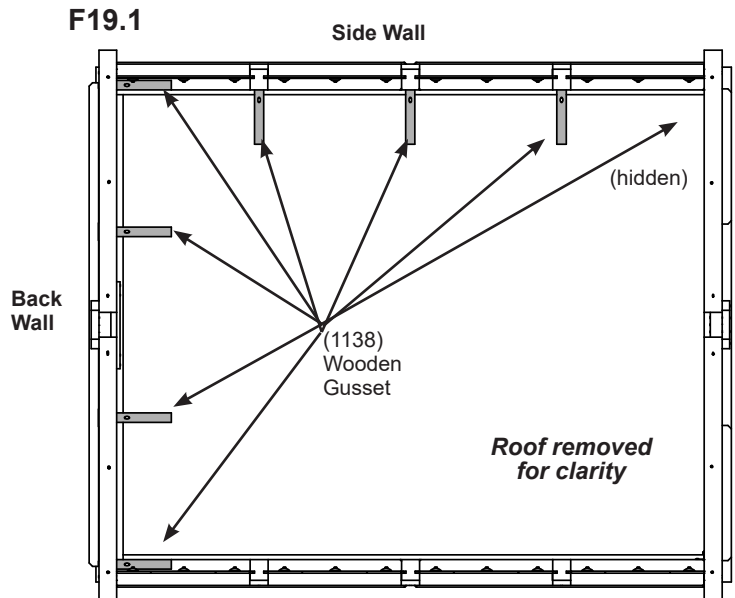

**F19.3
Top View**

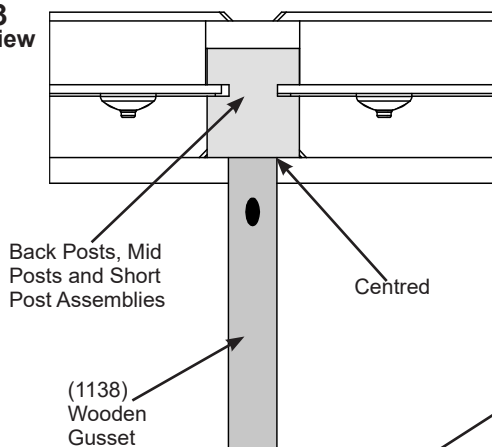

F19.4

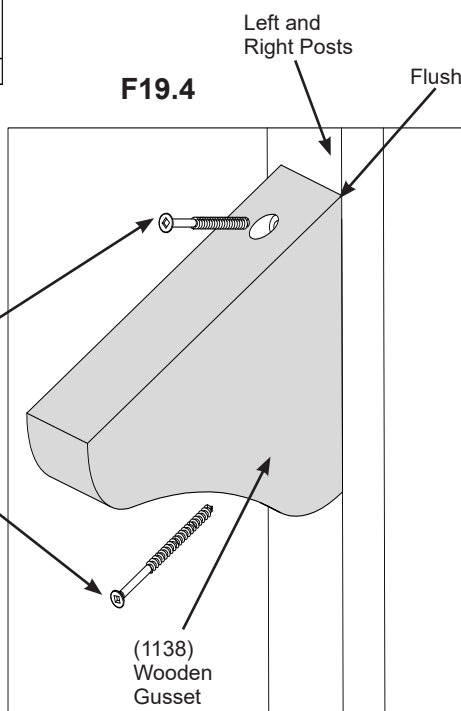

F19.2

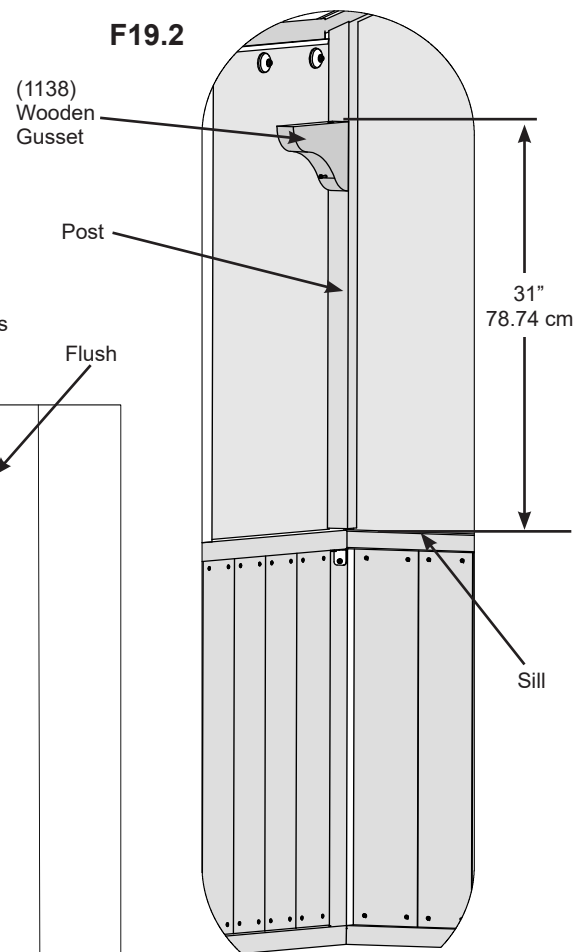

Wood Parts

8 x (1138) Wooden Gusset

Hardware

16 x #8 x 3" Wood Screw

Step 19: Upper Shelf Assembly Part 2

C: Tight to the Back Wall place two (1139) Short Upper Shelves on (1138) Wooden Gussets so they are tight to each other. Attach with four #8 x 1-1/4" Wood Screws per shelf. (F19.5 and F19.6)

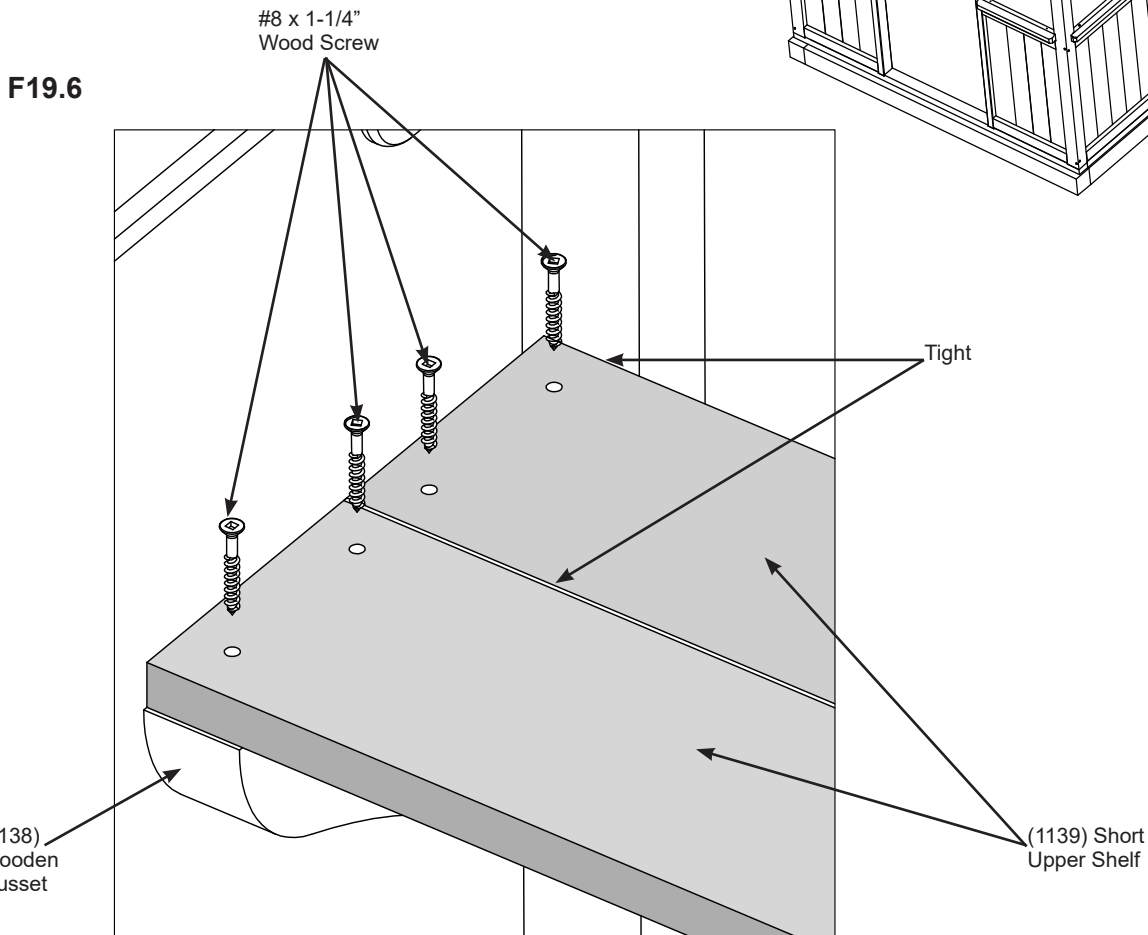
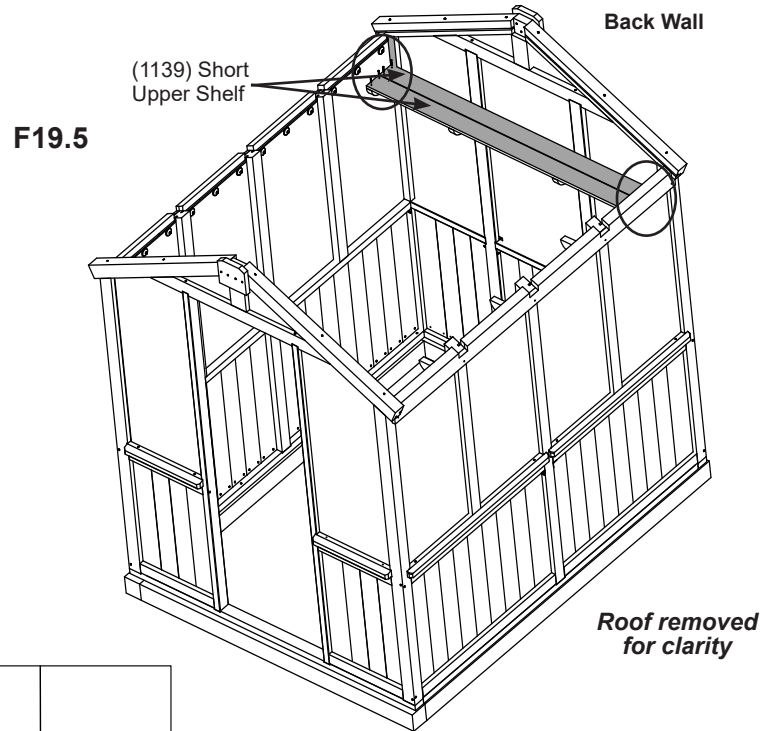

Wood Parts

2 x (1139) Short Upper Shelf

Hardware

8 x #8 x 1-1/4" Wood Screw

Step 19: Upper Shelf Assembly

Part 3

D: Over the two middle (1138) Wooden Gussets locate centre of each (1139) Short Upper Shelf then attach (1139) Short Upper Shelves to (1138) Wooden Gussets with two #8 x 1-1/4" Wood Screws per shelf. (F19.7)

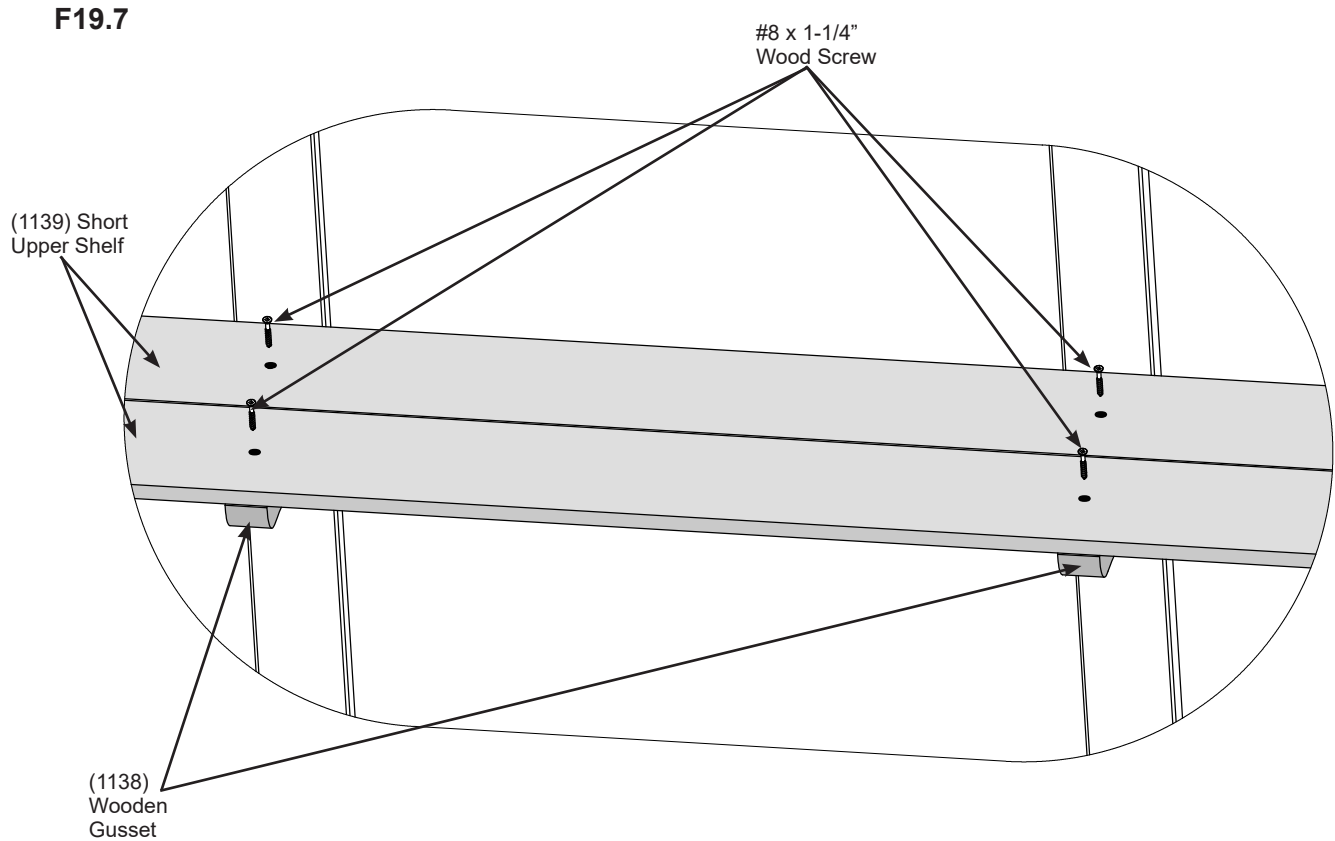

Hardware

4 x #8 x 1-1/4" Wood Screw

Step 19: Upper Shelf Assembly Part 4

E: Tight to the end (1138) Wooden Gusset, on the same side as the Side Wall gussets, place one (1141) Shelf Block under (1139) Short Upper Shelf and attach block to shelf with two #8 x 1-1/4" Wood Screws. (F19.8, F19.9 and F19.10)

F19.8

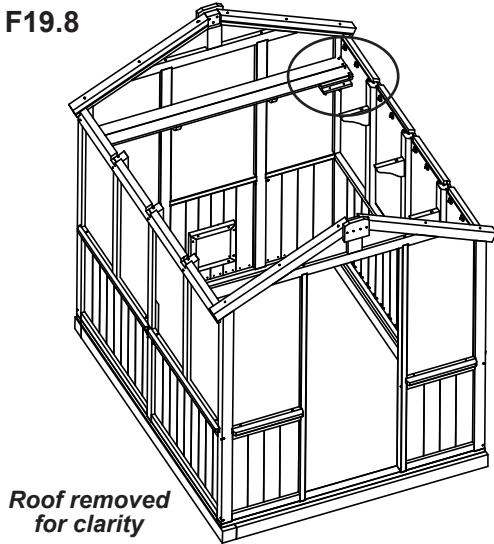

F19.9

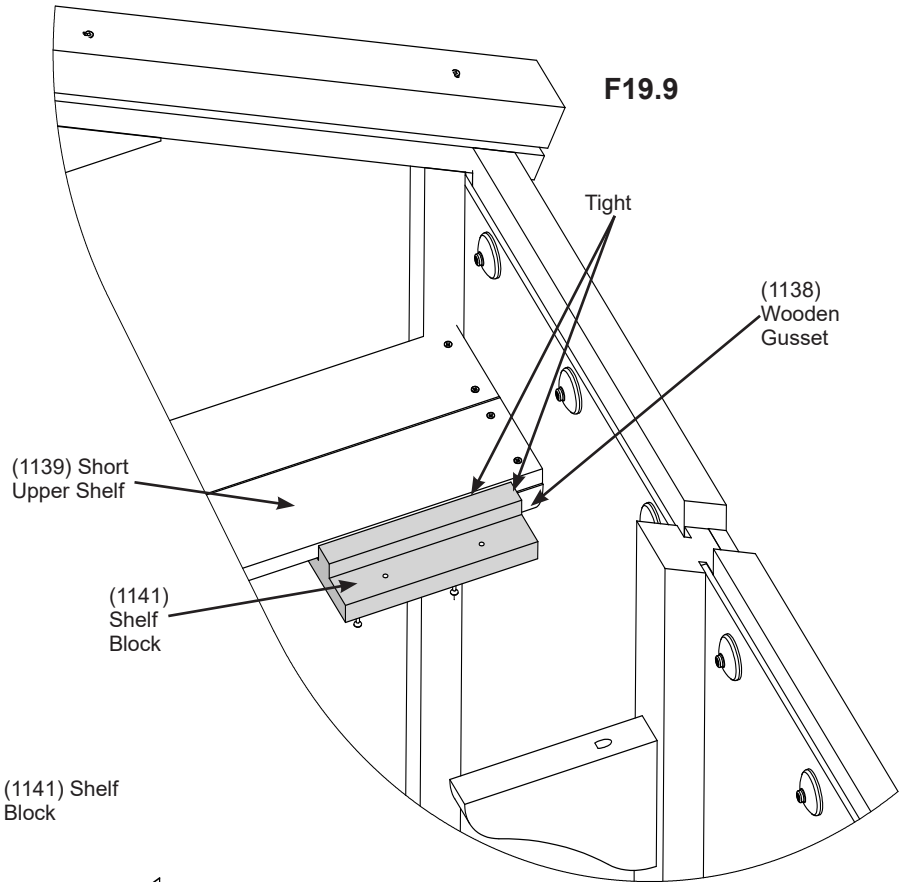

F19.10
Underside View

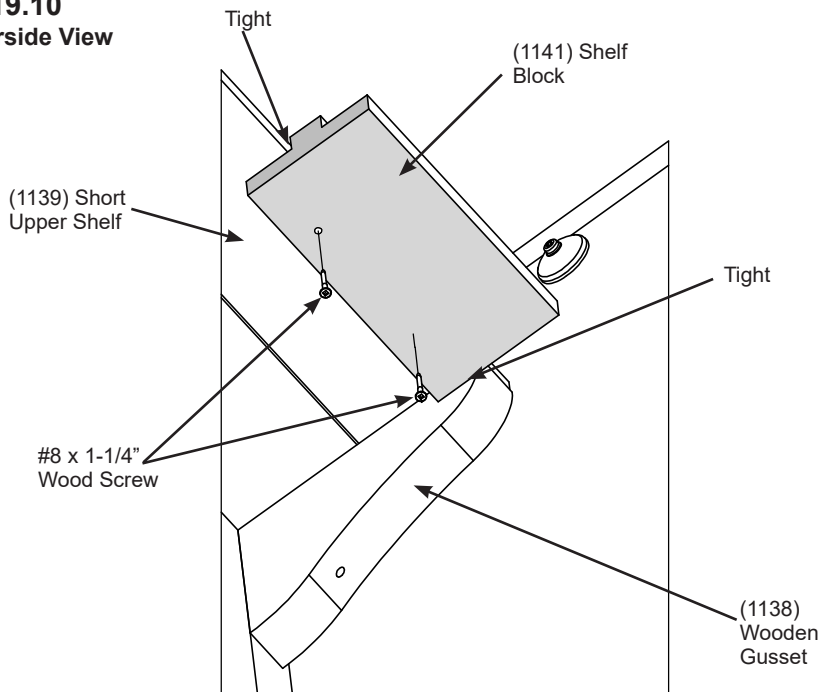

Wood Parts

1 x (1141) Shelf Block

Hardware

2 x #8 x 1-1/4" Wood Screw

Step 19: Upper Shelf Assembly Part 5

F: Tight to the Side Wall place two (1140) Long Upper Shelves on (1138) Wooden Gussets and (1141) Shelf Block. The ends with the pilot holes go on the Front Wall side, the other end is tight to (1141) Shelf Block. Attach (1140) Long Upper Shelves to Front Wall side (1138) Wooden Gusset with two #8 x 1-1/4" Wood Screws per shelf. (F19.11)

G: Over the three middle (1138) Wooden Gussets locate centre of each (1140) Long Upper Shelf then attach (1140) Long Upper Shelves to (1138) Wooden Gussets with three #8 x 1-1/4" Wood Screws per shelf. (F19.11)

H: Attach (1141) Shelf Block to both (1140) Long Upper Shelves with two #8 x 1-1/4" Wood Screws. (F19.12)

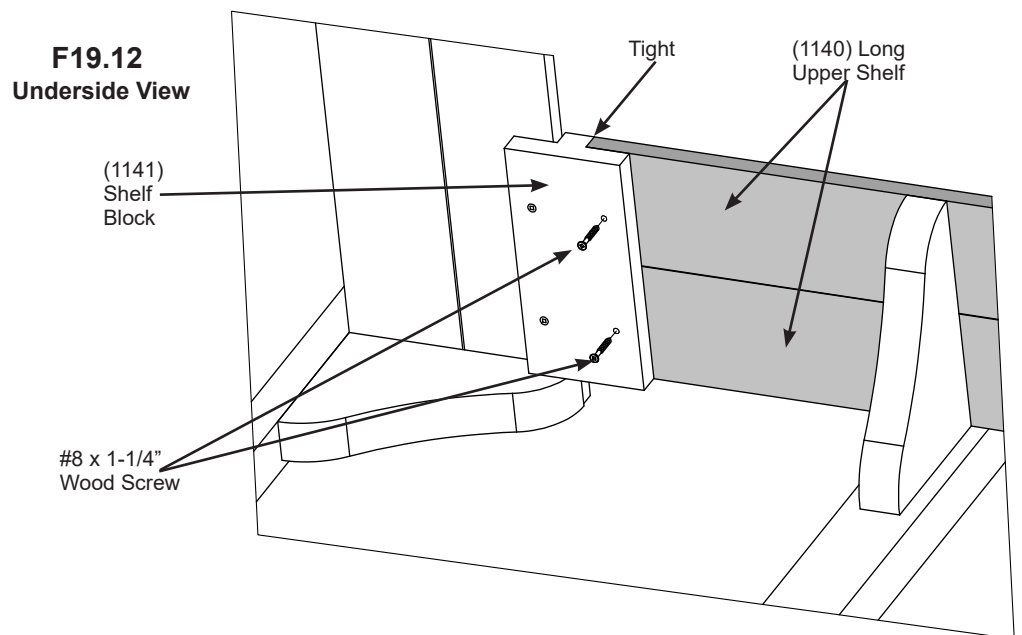
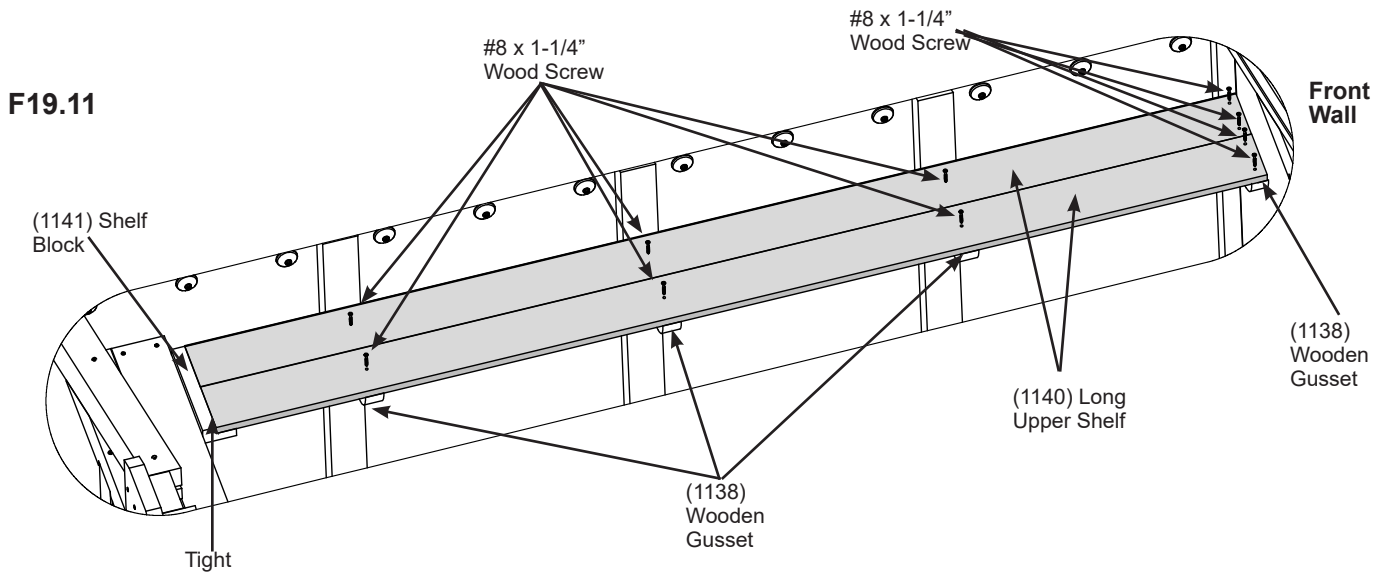

Wood Parts

2 x (1140) Long Upper Shelf

Hardware

12 x #8 x 1-1/4" Wood Screw

Step 20: Lower Shelf Assembly - Back Wall Part 1

A: On Back Wall place one (1134) Shelf Gusset on both (1108) Left Post and (1109) Right Post so (1134) Shelf Gussets fit tight to bottom of each (1107) Side Wall Sill. Attach to posts and sill with two #8 x 2-1/2" Wood Screws per gusset. (F20.1 and F20.2)

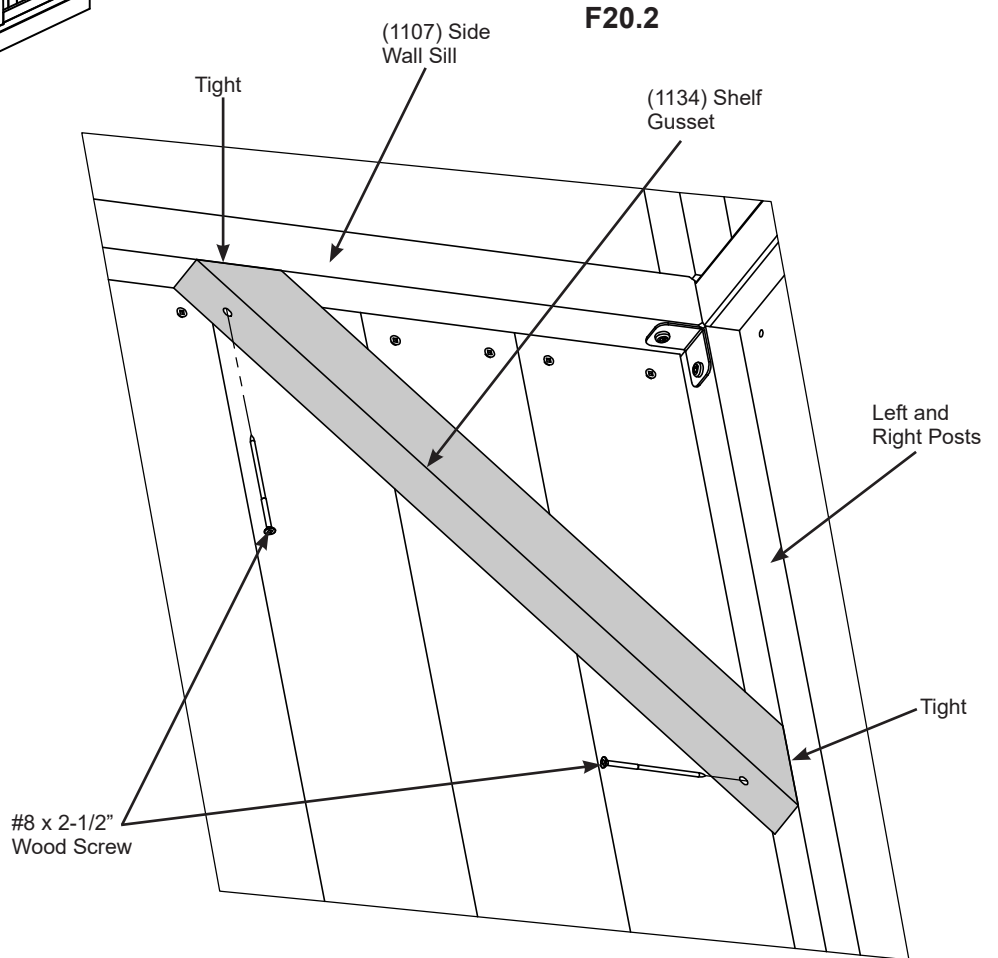
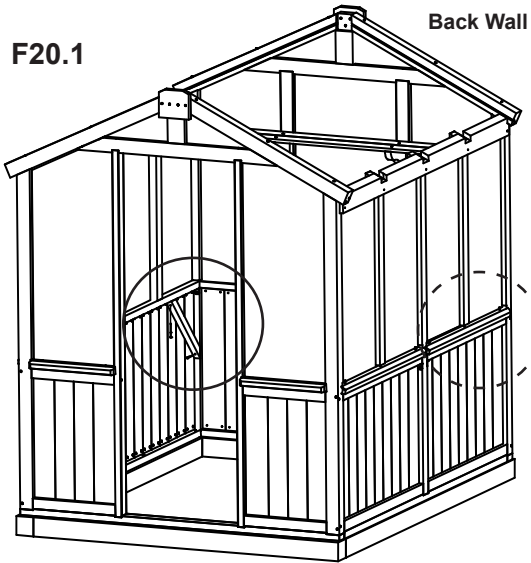

Wood Parts

2 x (1134) Shelf Gusset

Hardware

4 x #8 x 2-1/2" Wood Screw

Step 20: Lower Shelf Assembly - Back Wall

Part 2

B: On each side of the Back Wall, tight to bottom of (1106) Back Wall Sill and flush to bottom of (1107) Side Wall Sills place one (1137) Long Shelf Joist and attach to (1134) Shelf Gusset and posts with three #8 x 2-1/2" Wood Screws per joist. The screw going into the post is installed at an angle. (F20.3 and F20.4)

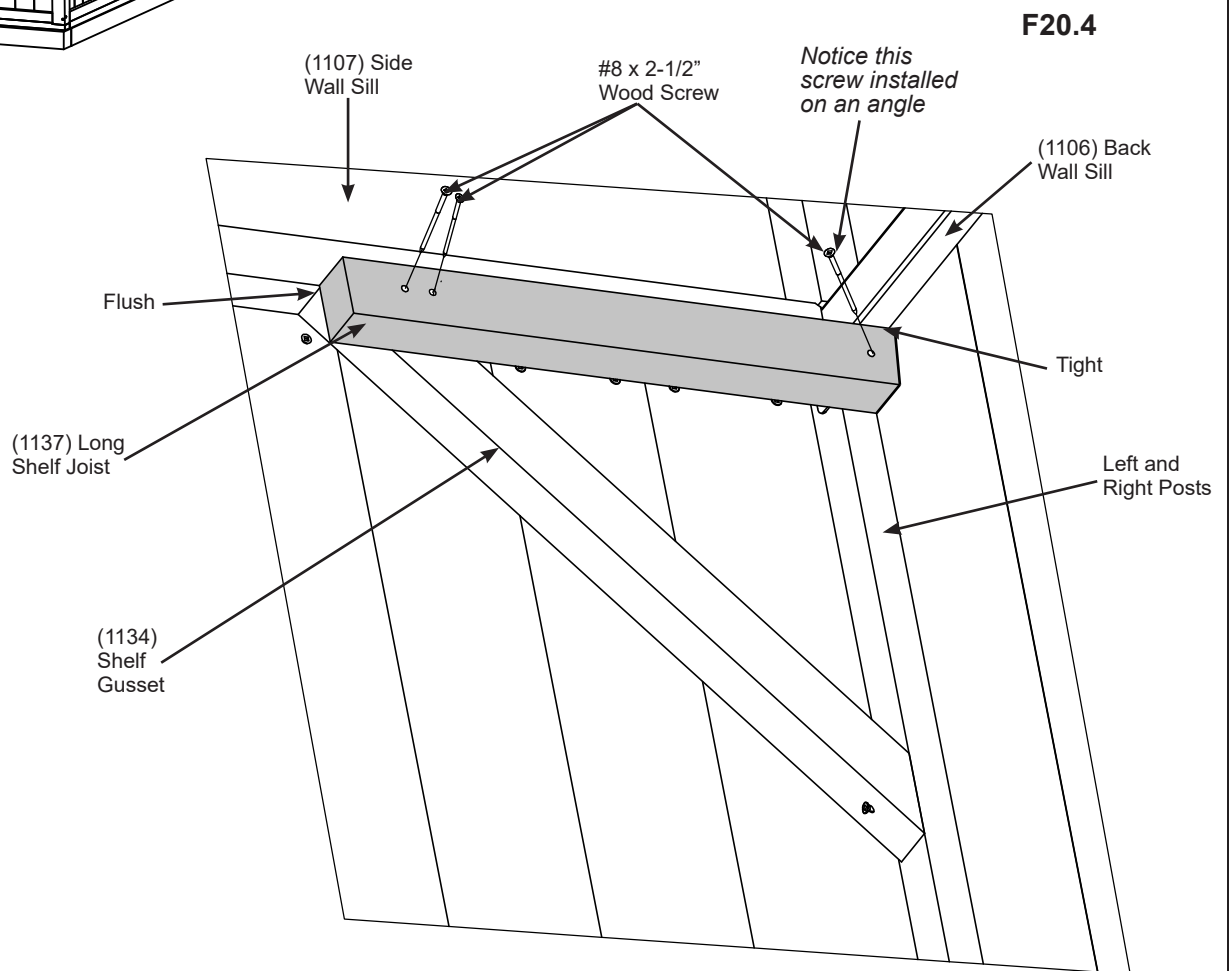

Wood Parts

2 x (1137) Long Shelf Joist

Hardware

6 x #8 x 2-1/2" Wood Screw

Step 20: Lower Shelf Assembly - Back Wall

Part 3



C: Place one (1132) Shelf Front against each (1137) Long Shelf Joist so it sits 5/8" (1.59 cm) above the joists. Notice the four holes are on the same side as where the Side Wall Shelf will go. Attach (1132) Shelf Front to (1137) Long Shelf Joists with two #8 x 2-1/2" Wood Screws. (F20.5, F20.6, F20.7 and F20.8)

F20.5

Back Wall

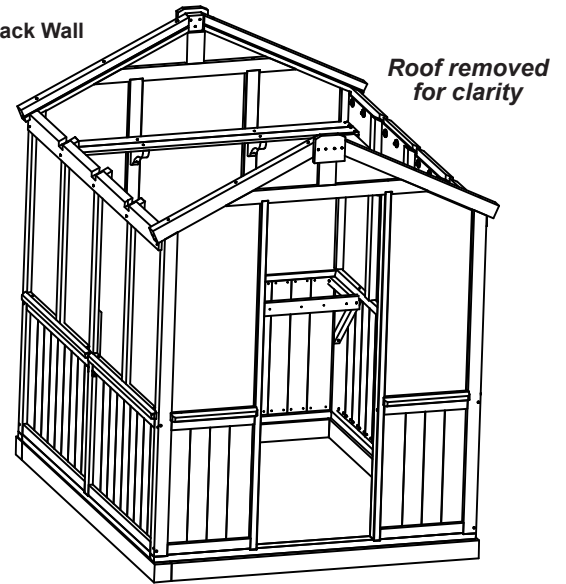

F20.6

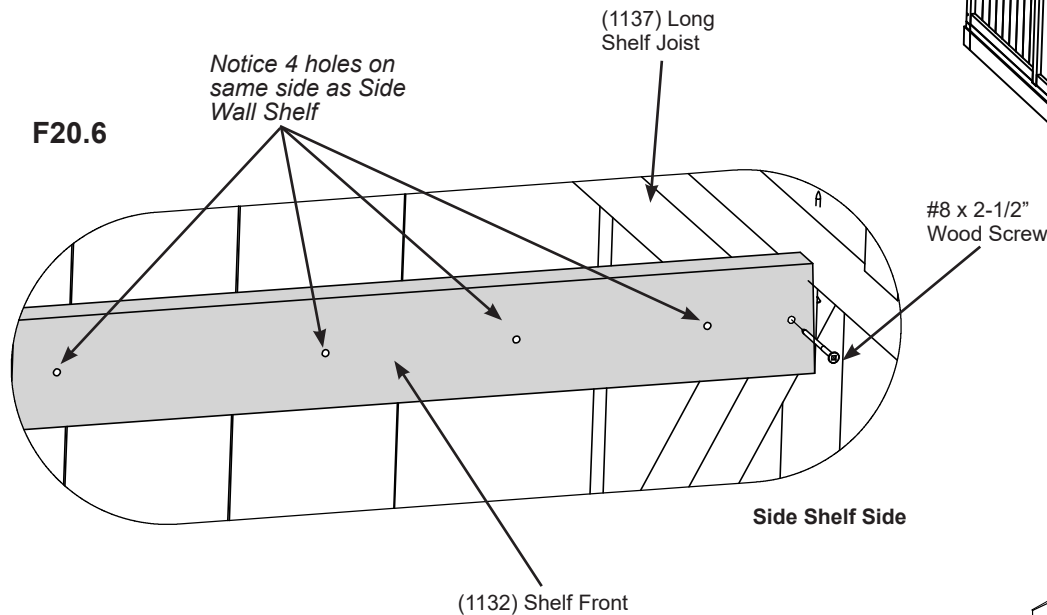

F20.7

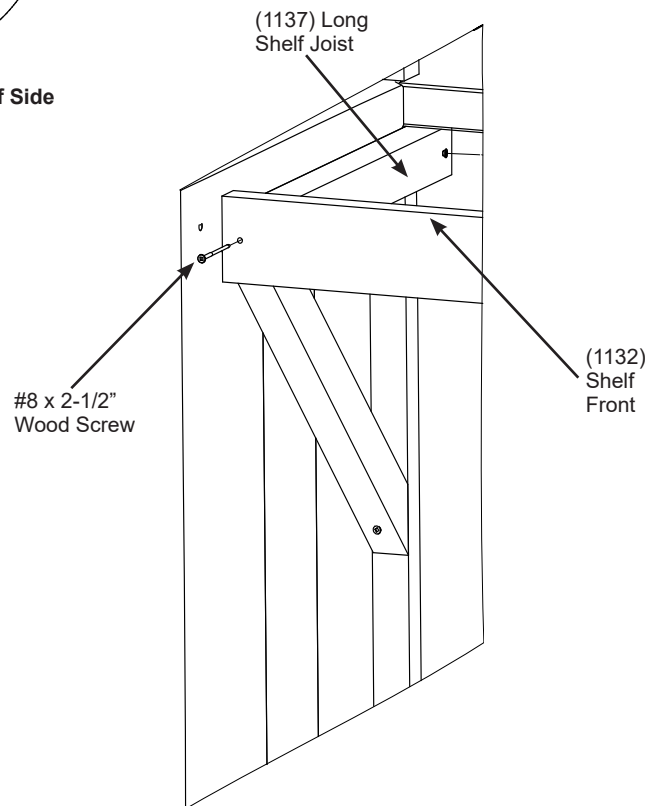

F20.8

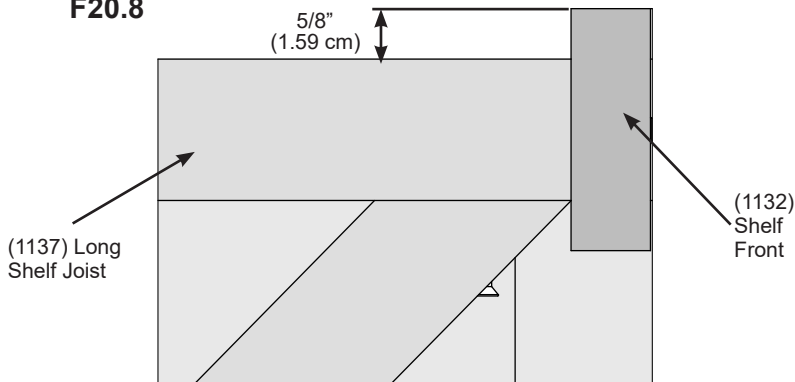

Wood Parts

1 x (1132) Shelf Front

Hardware

2 x #8 x 2-1/2" Wood Screw

Step 20: Lower Shelf Assembly - Back Wall

Part 4



D: From top of (1132) Shelf Front measure 5/8" (1.59 cm) down then on the front and right side place one (1135) Shelf Joist flush to the end. Attach (1132) Shelf Front to (1135) Shelf Joist with three #8 x 2" Wood Screws. (F20.9, F20.10 and F20.11)

F20.9

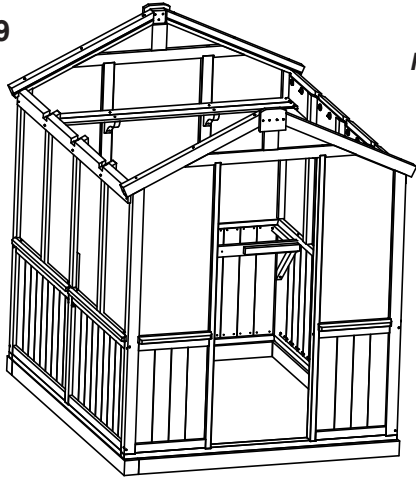

*Roof removed
for clarity*

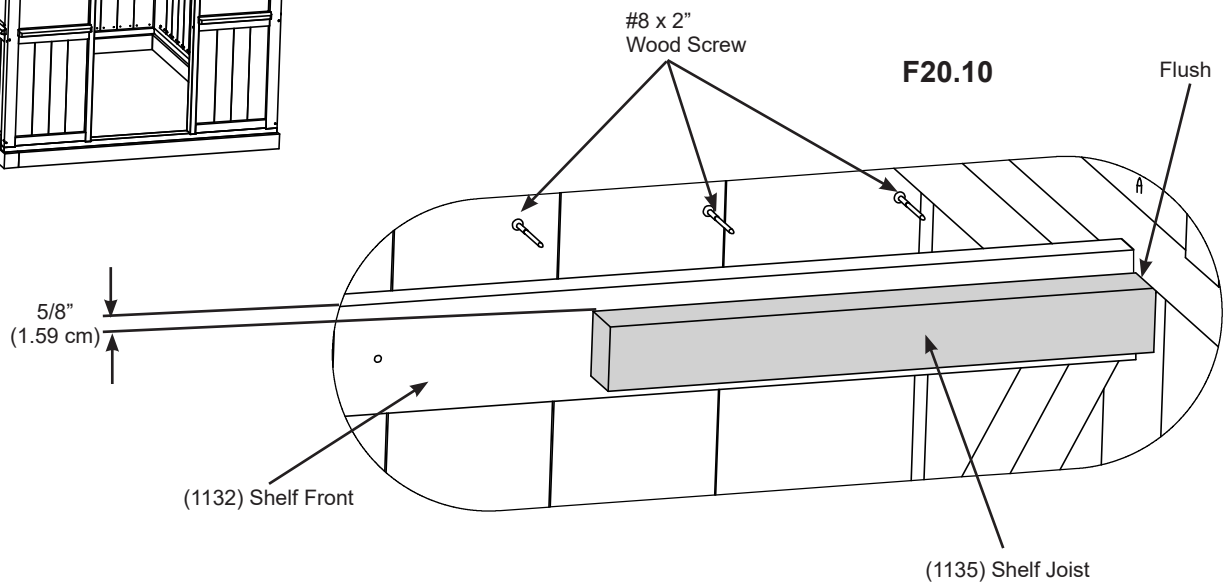

F20.10

F20.11
Inside View

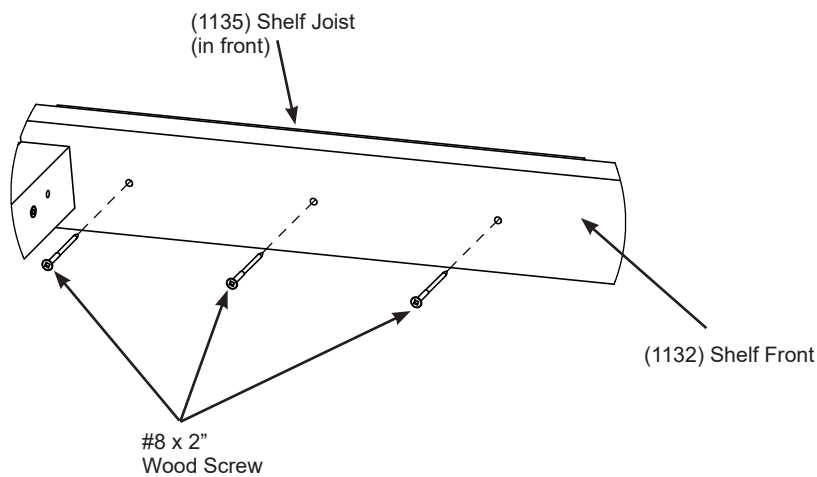

Wood Parts

1 x (1135) Shelf Joist

Hardware

3 x #8 x 2" Wood Screw

Step 20: Lower Shelf Assembly - Back Wall Part 5

E: Flush to one side of one (1135) Shelf Joist attach one Corner Bracket with one #10 x 1-1/4" Pan Screw. (F20.12)

F: Flush to the other side of (1135) Shelf Joist attach one (1134) Shelf Gusset with one #8 x 2-1/2" Wood Screw. (F20.12)

G: Repeat Steps E and F for a second Joist-Gusset Assembly. (F20.12)

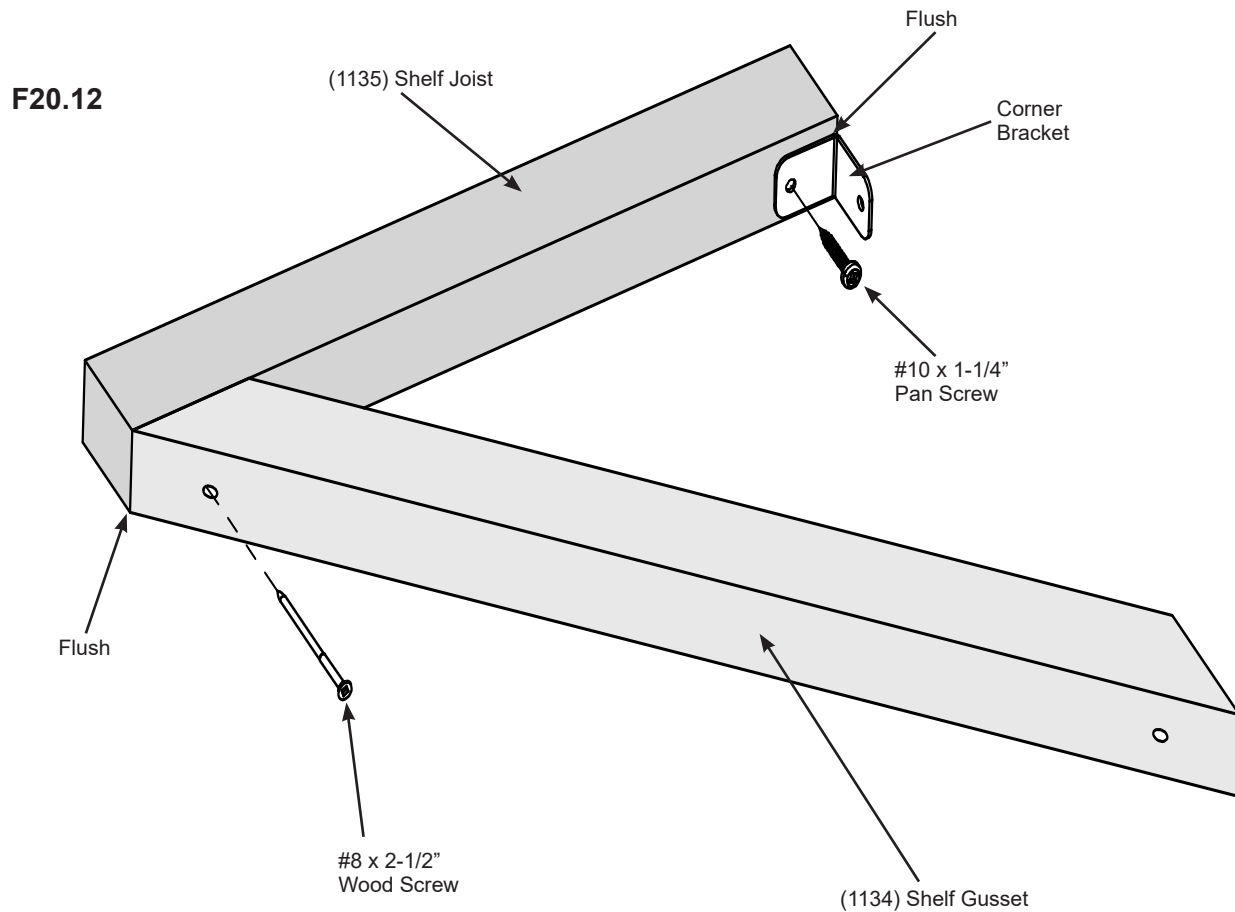

Wood Parts

2 x (1135) Shelf Joist
2 x (1134) Shelf Gusset

Components

2 x Corner Bracket

Hardware

2 x #10 x 1-1/4" Pan Screw
2 x #8 x 2-1/2" Wood Screw

Step 20: Lower Shelf Assembly - Back Wall Part 6



H: Tight to each (1113) Back Post place one Joist-Gusset Assembly so (1135) Shelf Joist is level with the bottom of (1106) Back Wall Sill then attach Corner Brackets to (1113) Back Posts with one #10 x 1-1/4" Pan Screw per bracket. (F20.13, F20.14 and F20.16)

I: Attach (1134) Shelf Gussets to (1113) Back Posts with one #8 x 2-1/2" Wood Screw per gusset. (F20.13, F20.14 and F20.15)

J: Make sure Joist-Gusset Assembly sits 5/8" (1.59 cm) down from the top of (1132) Shelf Front and is centred over the pilot holes. Attach (1132) Shelf Front to (1135) Shelf Joists with one #8 x 2-1/2" Wood Screw per joist. (F20.13, F20.14 and F20.15)

F20.13

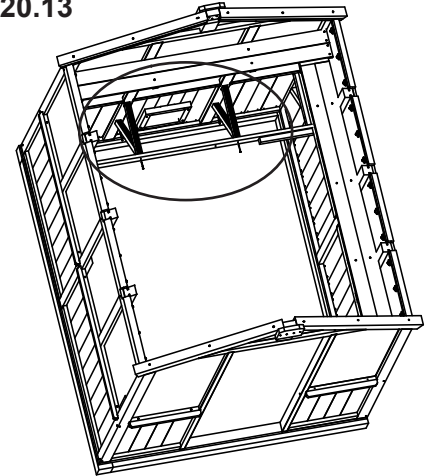

Roof removed for clarity

F20.14

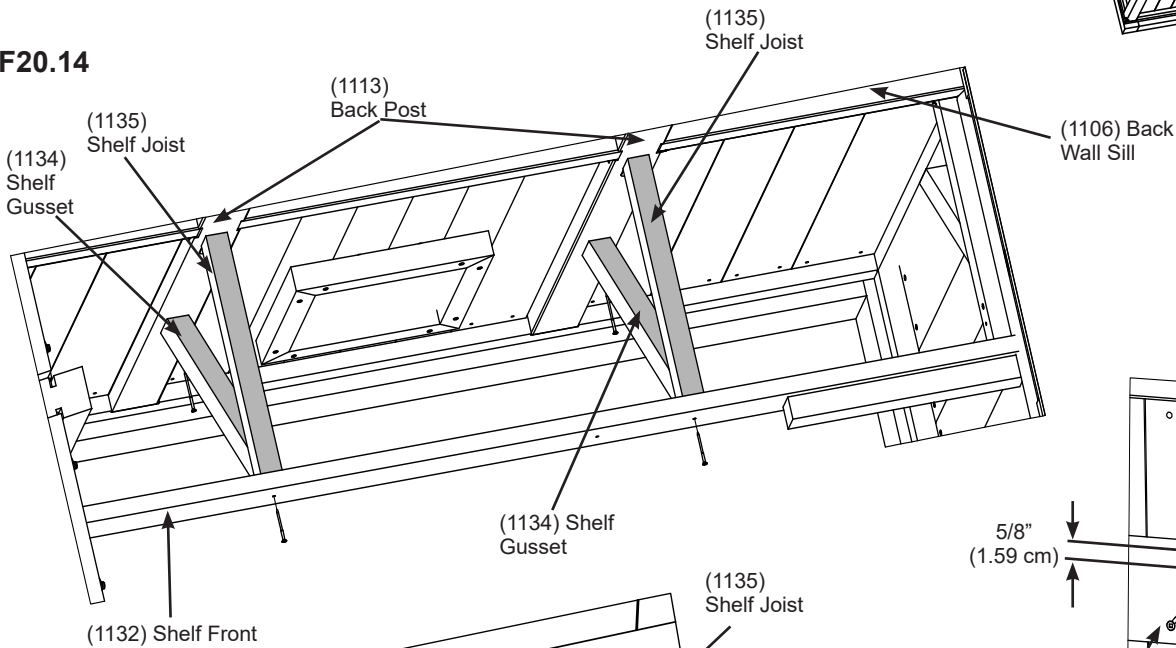

F20.15

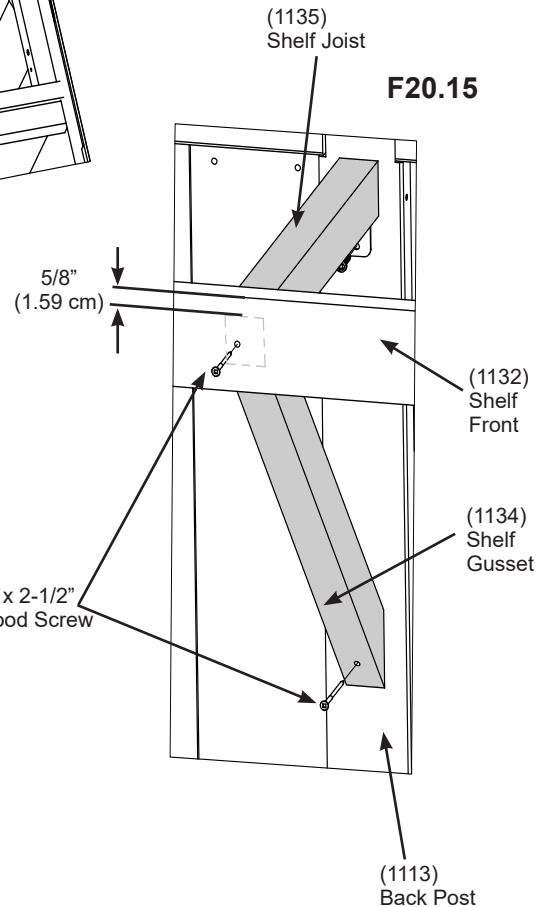

F20.16

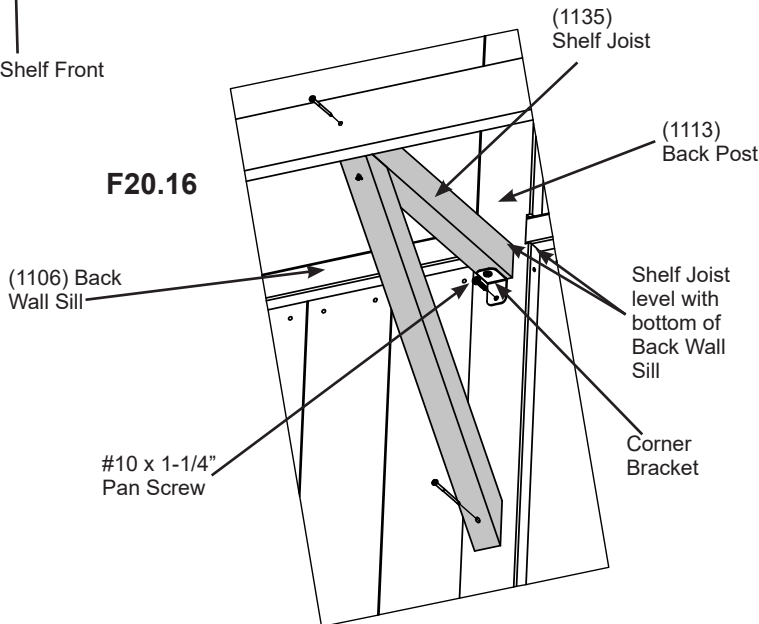

Hardware

- 2 x #10 x 1-1/4" Pan Screw
- 4 x #8 x 2-1/2" Wood Screw

Step 21: Lower Shelf Assembly - Side Wall

Part 1



A: Place one (1135) Shelf Joist so it is in alignment with the notch in (1133) Shelf Side. The distance from the top of (1135) Shelf Joist to the top of (1133) Shelf Side is 5/8" (1.59 cm). Attach (1133) Shelf Side to (1135) Shelf Joist with three #8 x 2" Wood Screws. (F21.1 and F21.2)

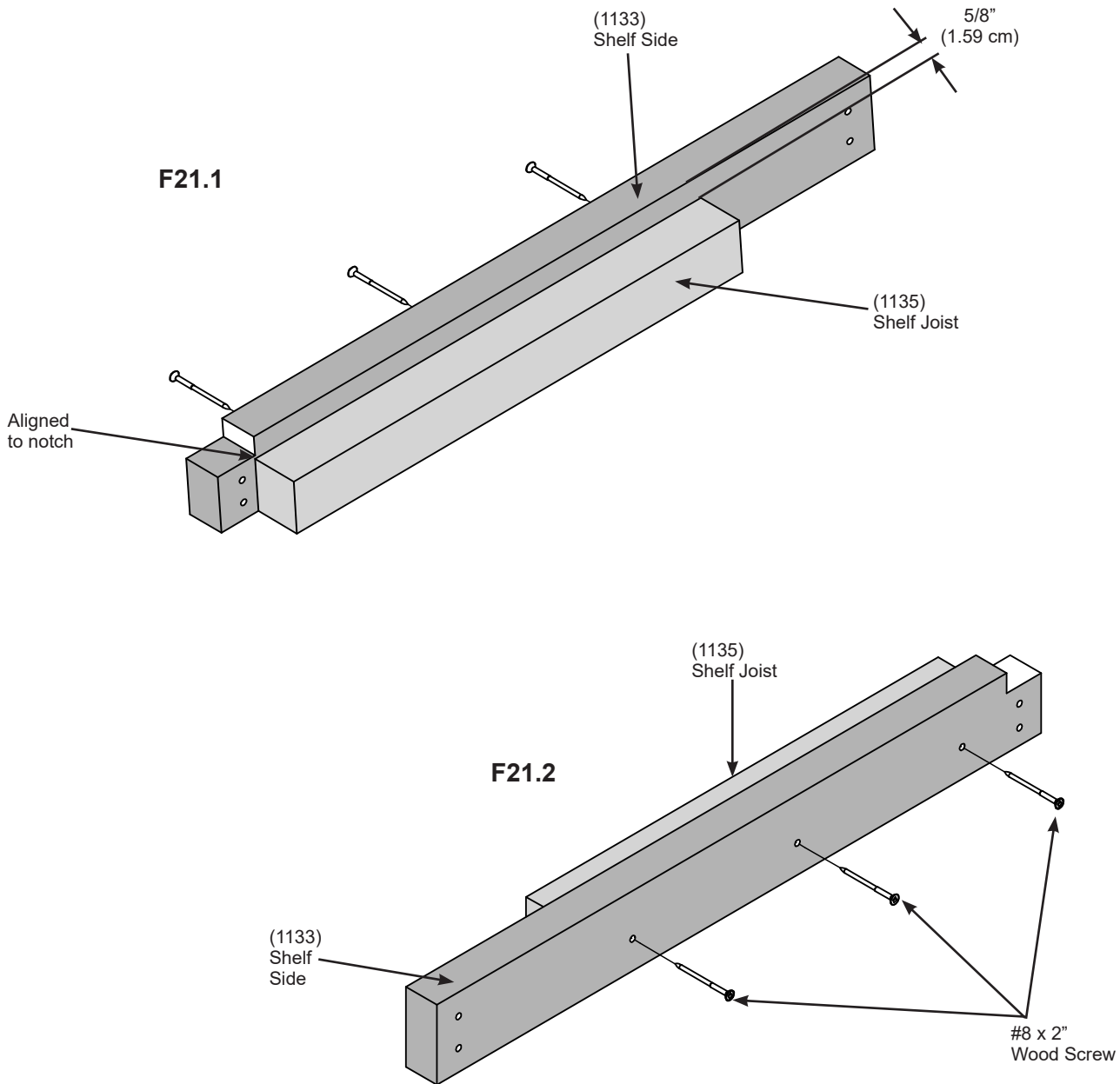

Wood Parts

- 1 x (1133) Shelf Side
- 1 x (1135) Shelf Joist

Hardware

- 3 x #8 x 2" Wood Screw

Step 21: Lower Shelf Assembly - Side Wall Part 2



B: On the Front Wall, on the same side as the Lower Shelf will be installed, remove the Corner Bracket which connects the Front and Side Walls. (F21.3 and F21.4)

C: Place Side Shelf Assembly against the Front Wall so the notch side sits tight to the Side Wall and (1107) Side Wall Sill and to the Right or Left Post and Door Post. (1135) Shelf Joist faces away from the Front Wall. Make sure (1133) Shelf Side is level then attach to Front Wall with four #8 x 2-1/2" Wood Screws. (F21.3 and F21.5)

F21.3

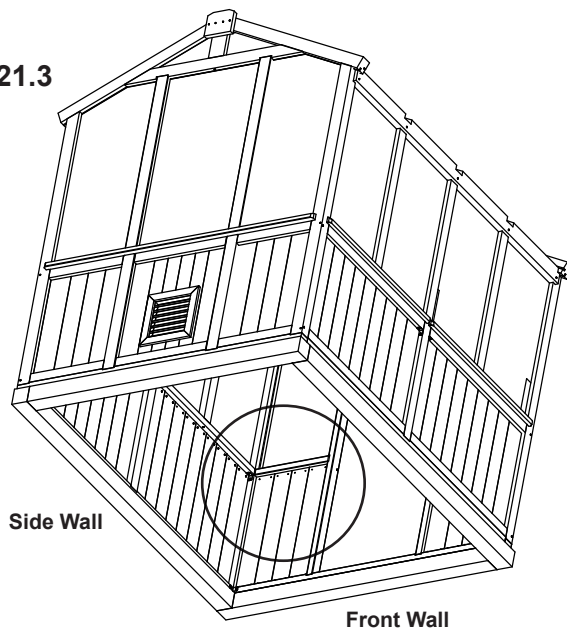

F21.4

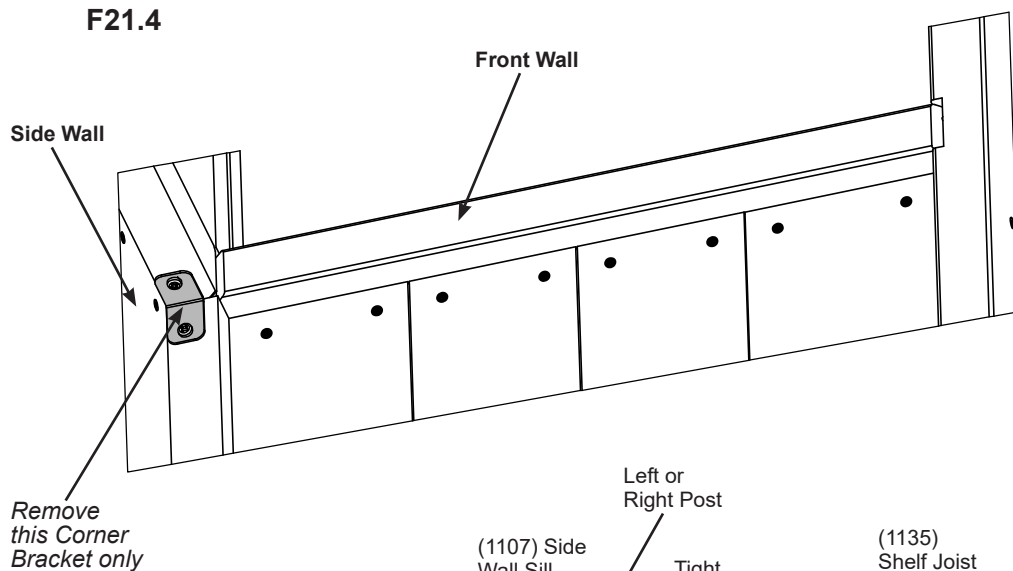

F21.5

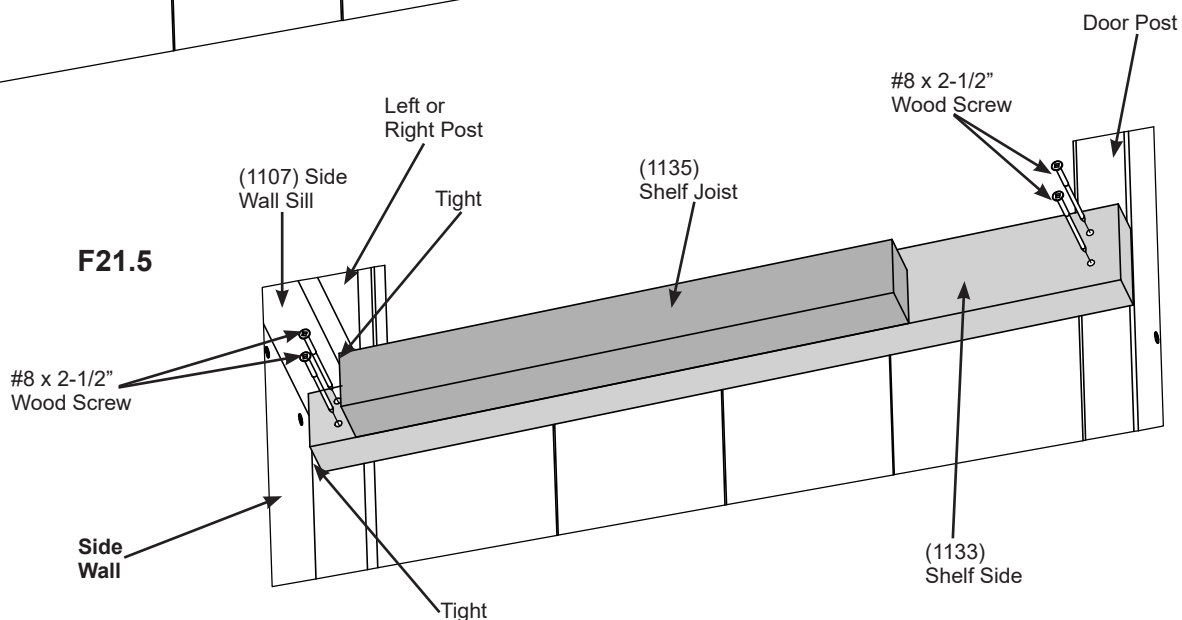

Hardware

4 x #8 x 2-1/2" Wood Screw

Step 21: Lower Shelf Assembly - Side Wall

Part 3



D: Place one (1132) Shelf Front against each (1135) Shelf Joist so it sits 5/8" (1.59 cm) above the joists. Notice the four holes are towards the Back Wall. Attach (1132) Shelf Front to (1135) Shelf Joists with two #8 x 2-1/2" Wood Screws. (F21.6, F21.7, F21.8 and F21.9)

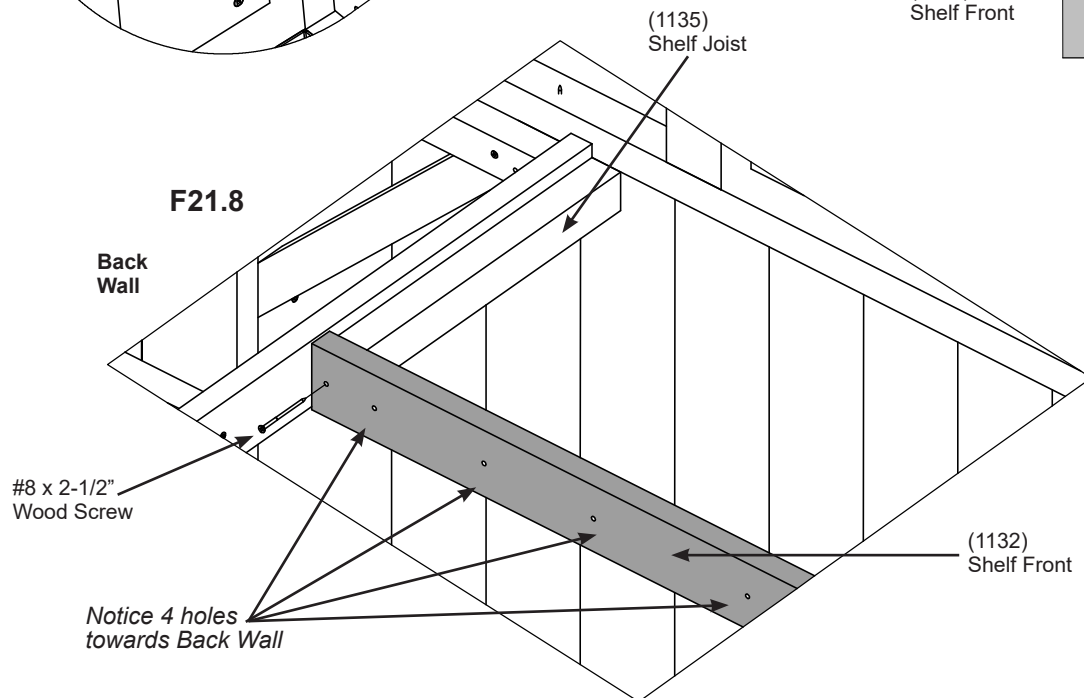
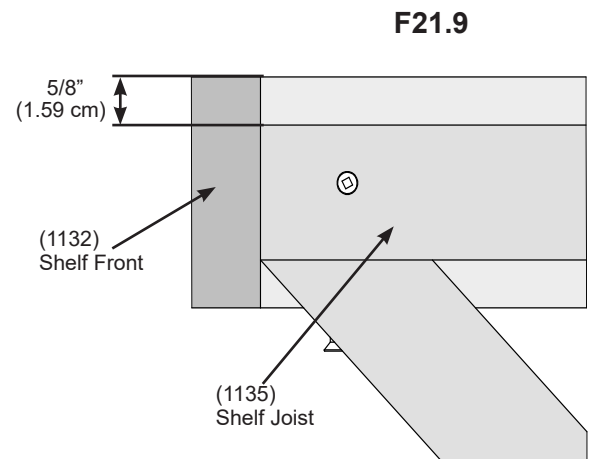
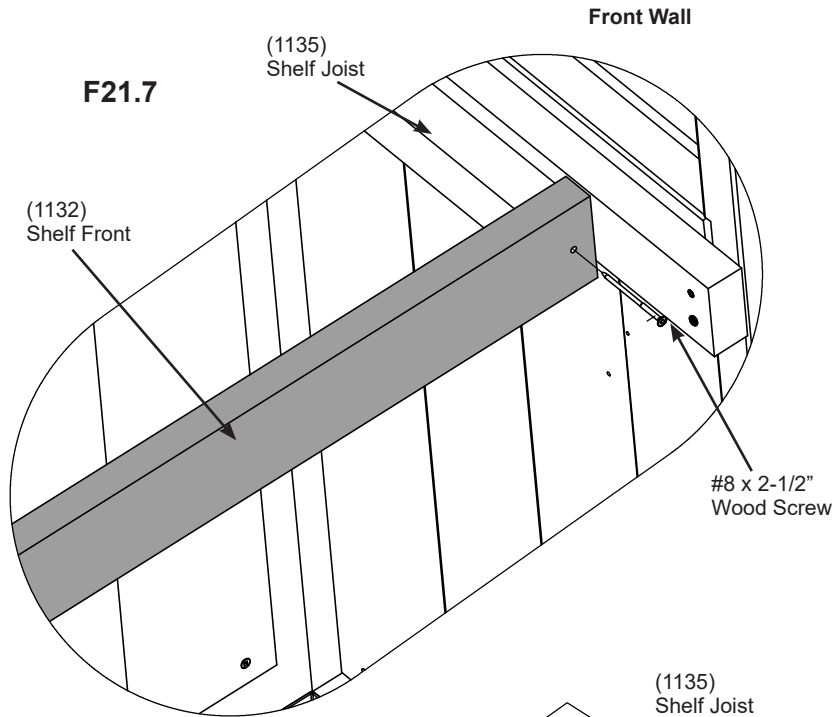
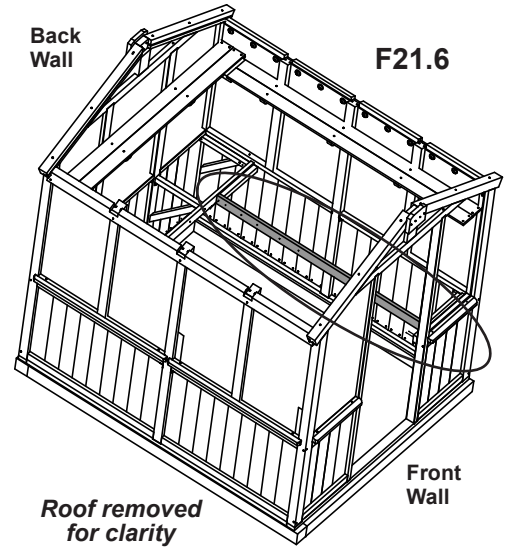

Wood Parts

1 x (1132) Shelf Front

Hardware

2 x #8 x 2-1/2" Wood Screw

Step 21: Lower Shelf Assembly - Side Wall

Part 4

E: Flush to one side of one (1135) Shelf Joist attach one Corner Bracket with one #10 x 1-1/4" Pan Screw. (F21.10)

F: Flush to the other side of (1135) Shelf Joist attach one (1134) Shelf Gusset with one #8 x 2-1/2" Wood Screw. (F21.10)

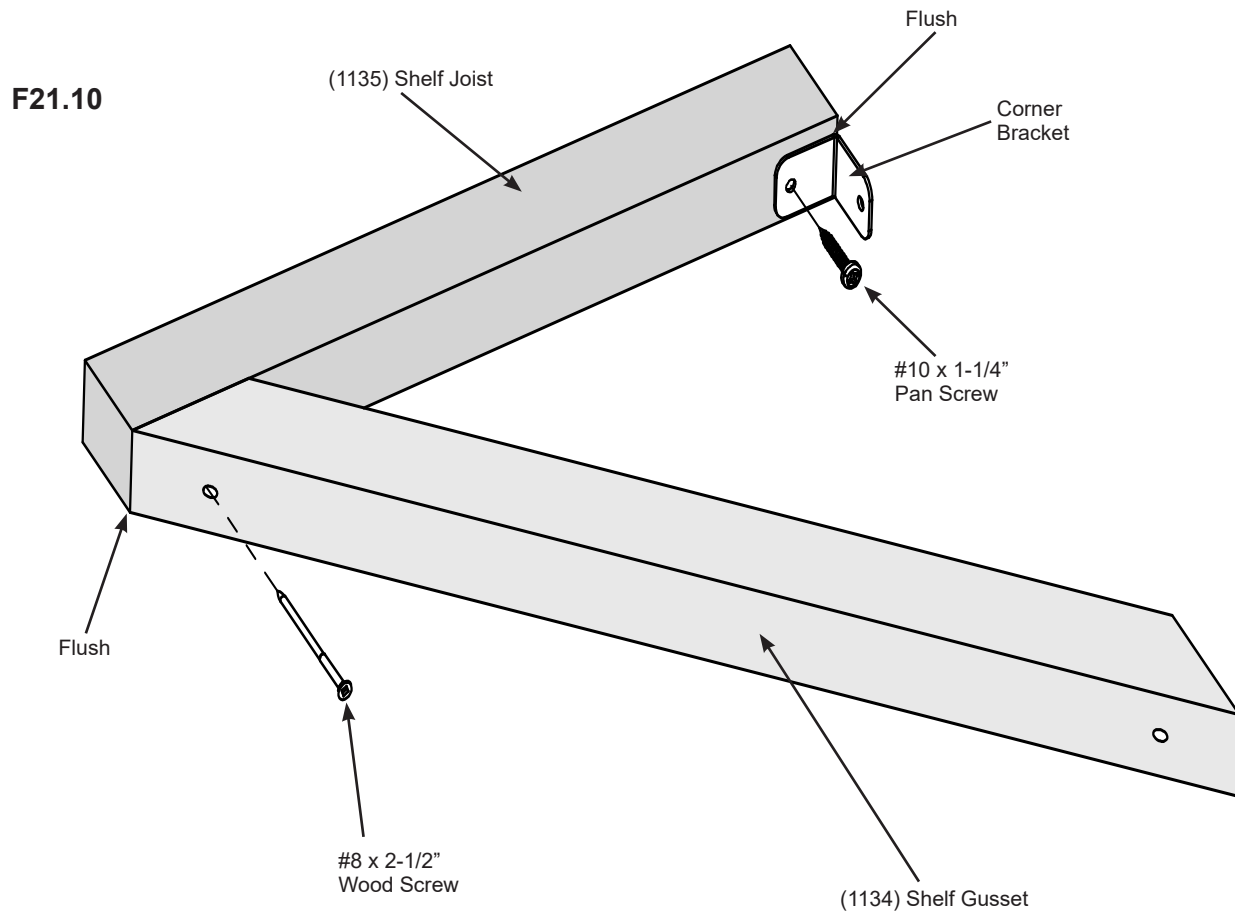

Wood Parts

- 1 x (1135) Shelf Joist
- 1 x (1134) Shelf Gusset

Components

- 1 x Corner Bracket

Hardware

- 1 x #10 x 1-1/4" Pan Screw
- 1 x #8 x 2-1/2" Wood Screw

Step 21: Lower Shelf Assembly - Side Wall Part 5



G: Tight to (1110) Mid Post place Joist-Gusset Assembly so (1135) Shelf Joist is level with the bottom of (1107) Side Wall Sill then attach Corner Bracket to (1110) Mid Post with one #10 x 1-1/4" Pan Screw. (F21.11, F21.12 and F21.13)

H: Attach (1134) Shelf Gusset to (1110) Mid Post with one #8 x 2-1/2" Wood Screw. (F21.11, F21.12 and F21.13)

I: Make sure Joist-Gusset Assembly sits 5/8" (1.59 cm) down from the top of (1132) Shelf Front and is centred over the pilot holes. Attach (1132) Shelf Front to (1135) Shelf Joist with one #8 x 2-1/2" Wood Screw. (F21.11, F21.12 and F21.13)

F21.11

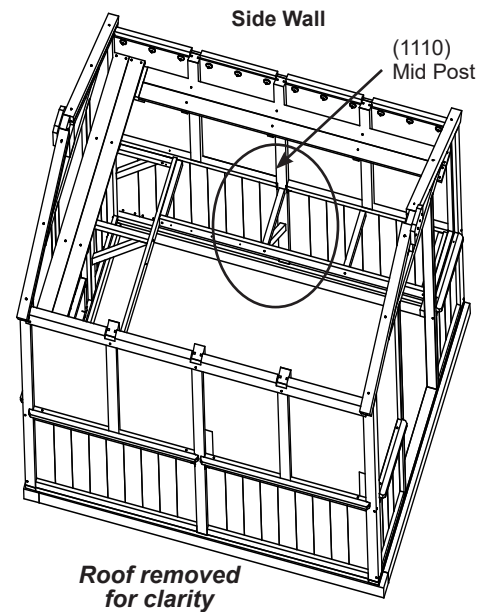

F21.12

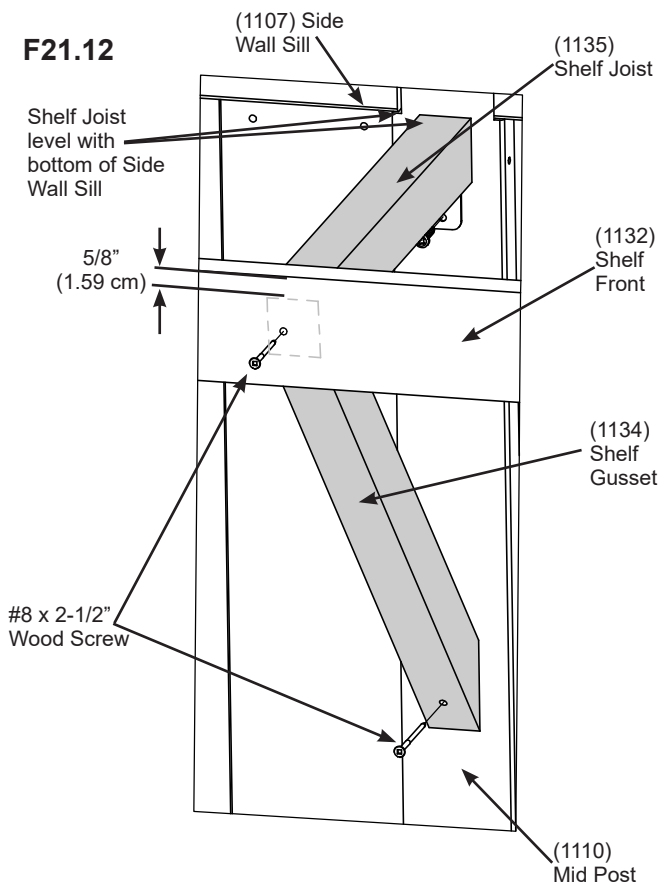

F21.13

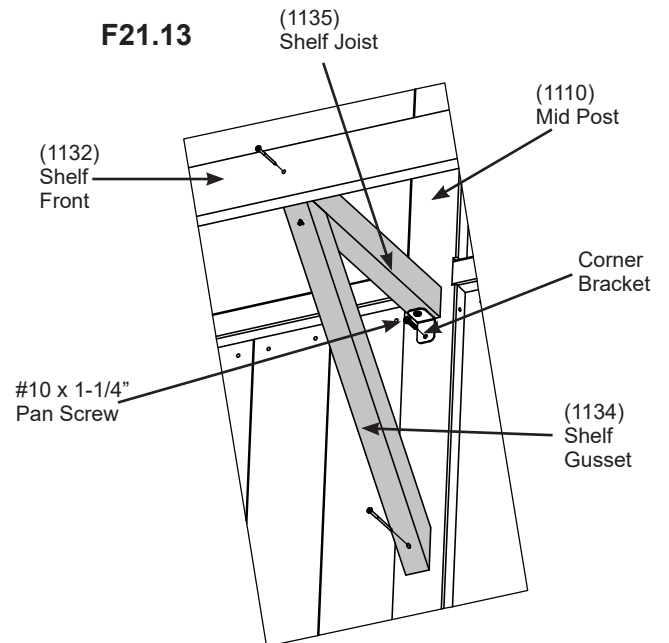

Hardware

- 1 x #10 x 1-1/4" Pan Screw
- 2 x #8 x 2-1/2" Wood Screw

Step 22: Attach Shelf Tops

Part 1

A: Tight to the Back Wall place four (1131) Shelf Tops on (1137) Long Shelf Joists and (1135) Shelf Joists so they are evenly spaced. Attach (1131) Shelf Tops to (1137) Long Shelf Joists with four #8 x 1-1/4" Wood Screws per board. Find the centre of each (1135) Shelf Joist then attach (1131) Shelf Tops to (1135) Shelf Joists with two #8 x 1-1/4" Wood Screws per board. (F22.1 and F22.2)

B: Tight to the Side Wall place four (1131) Shelf Tops on (1135) Shelf Joists. Attach (1131) Shelf Tops to end joists with four #8 x 1-1/4" Wood Screws per shelf. Find the centre of middle (1135) Shelf Joist then attach (1131) Shelf Tops to (1135) Shelf Joist with one #8 x 1-1/4" Wood Screws per board. (F22.1 and F22.3)

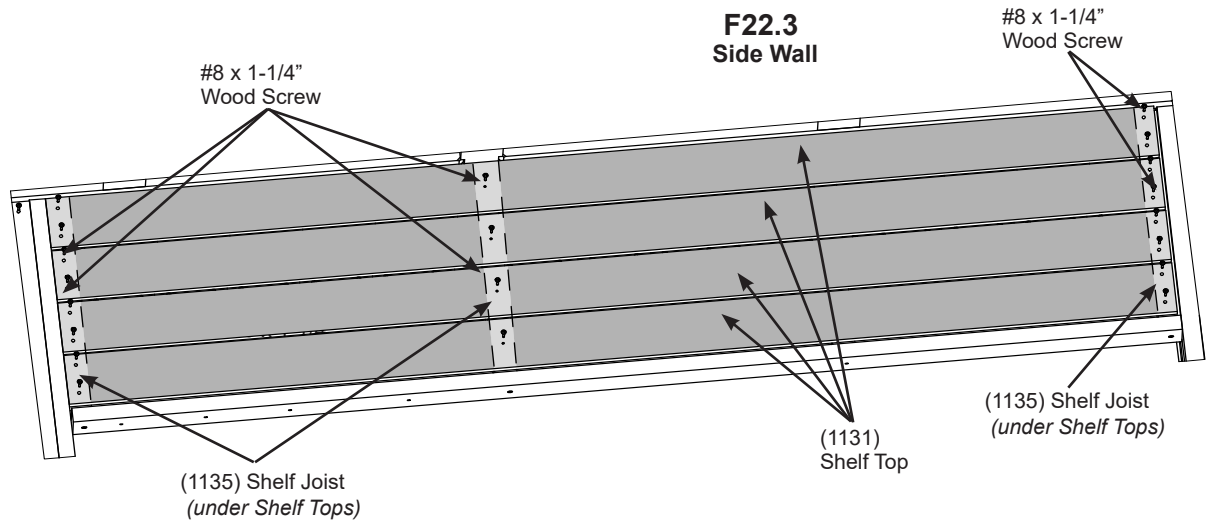
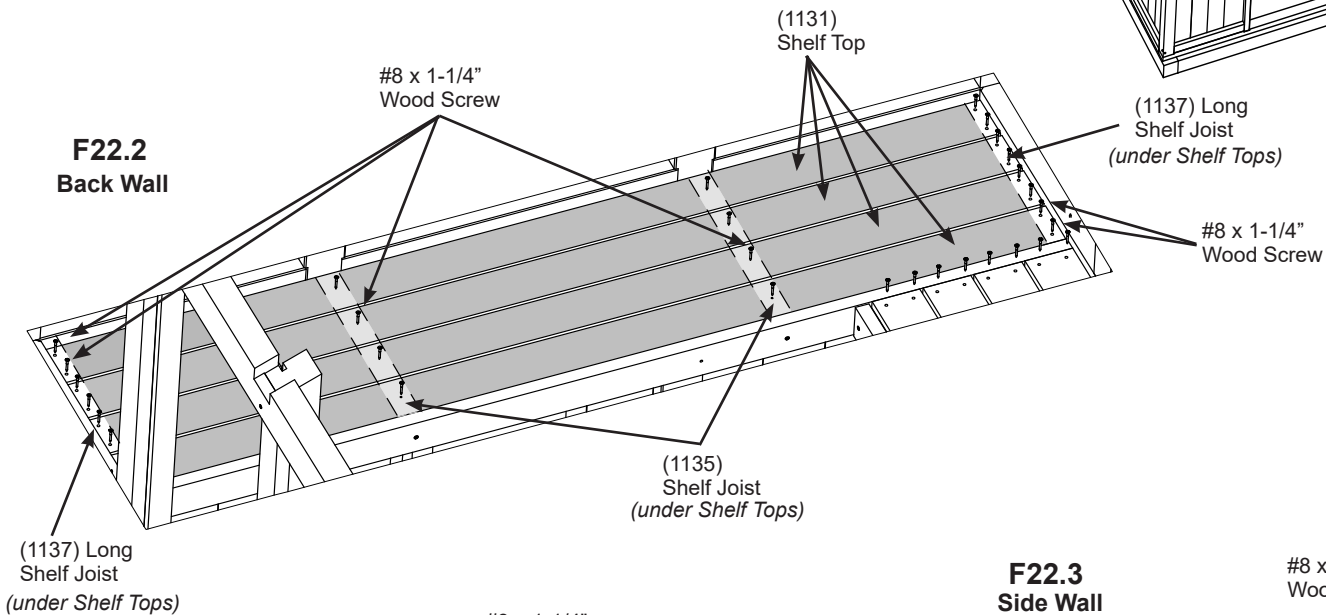
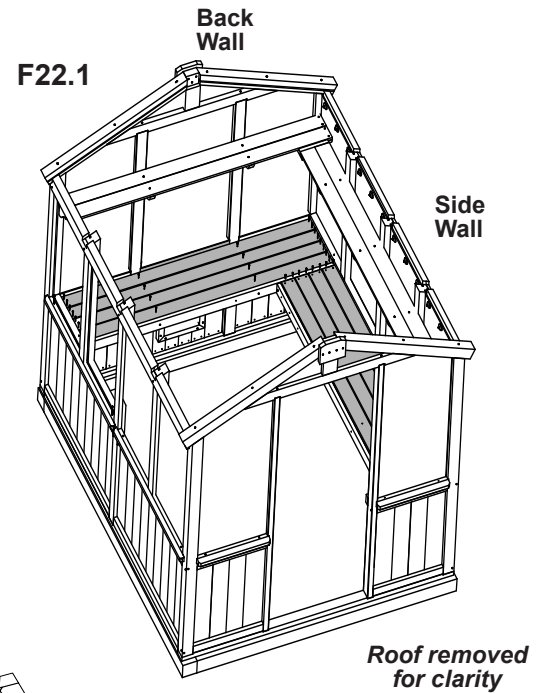

Wood Parts

8 x (1131) Shelf Top

Hardware

44 x #8 x 1-1/4" Wood Screw

Step 22: Attach Shelf Tops Part 2



C: Under (1131) Shelf Tops on Side Wall side place one (1135) Shelf Joist centred over pilot hole closest to the Front Wall in (1132) Shelf Front then attach with one #8 x 2-1/2" Wood Screw. (F22.4 and F22.5)

D: Find the centre of (1135) Shelf Joist then attach (1131) Shelf Tops to (1135) Shelf Joist with one #8 x 1-1/4" Wood Screw per board. (F22.4 and F22.5)

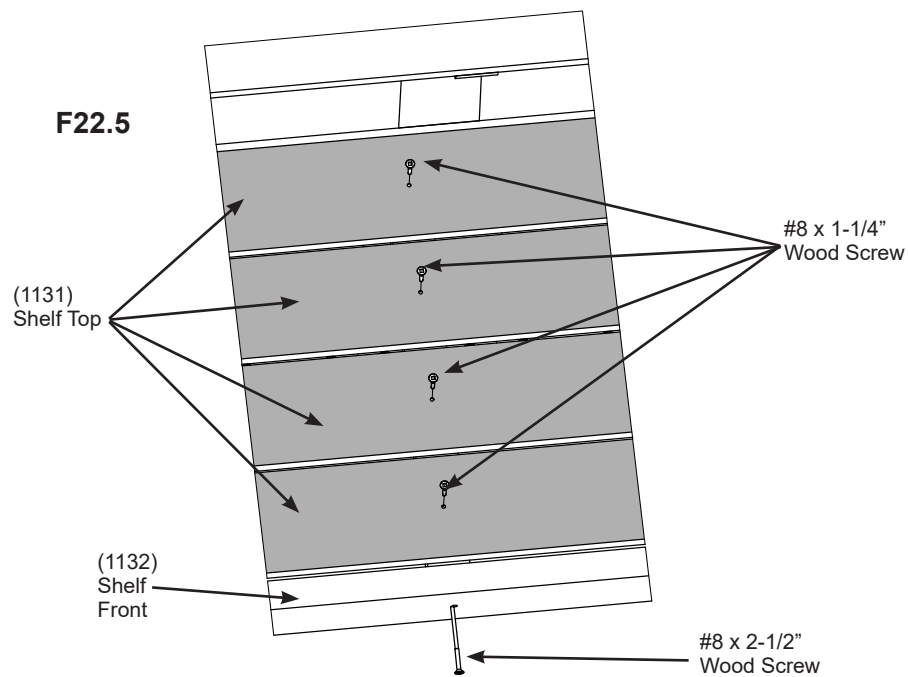
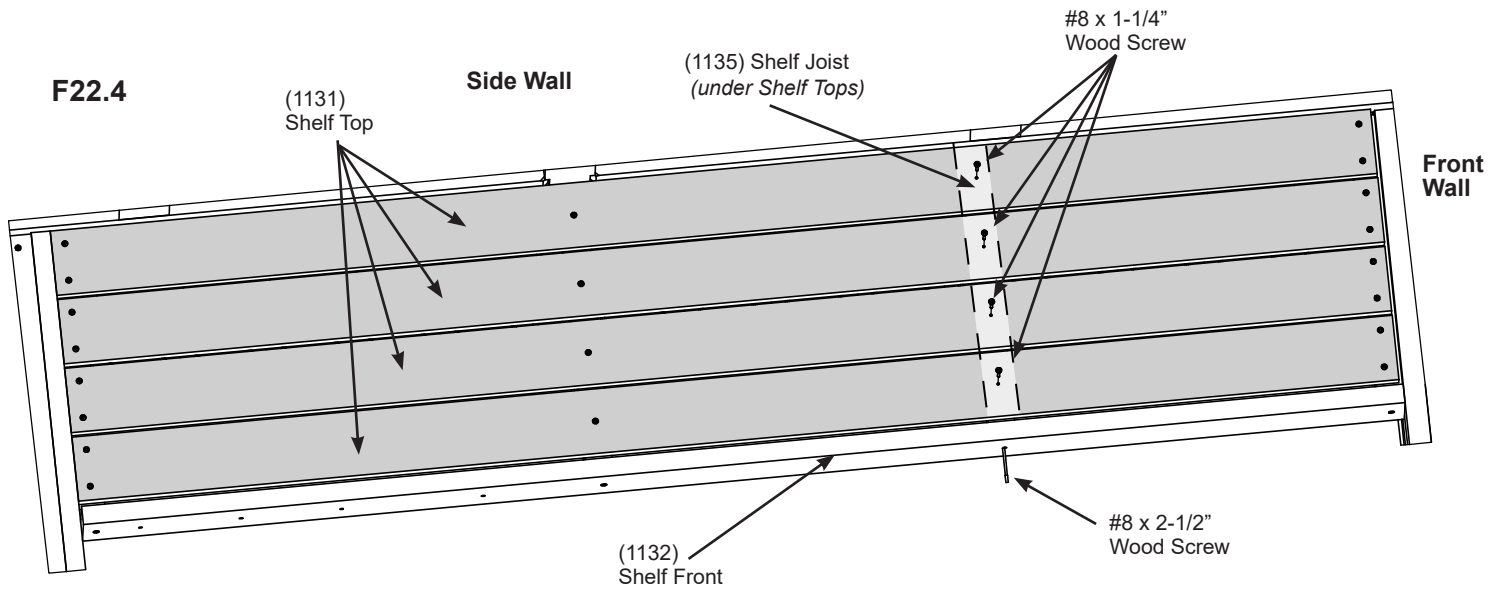

Wood Parts

1 x (1135) Shelf Joist

Hardware

4 x #8 x 1-1/4" Wood Screw

1 x #8 x 2-1/2" Wood Screw

Step 23: Door Assembly Part 1



A: Tight to bottom of (1143) Front Gable Beam, flush to the inside edge, attach (1129) Top Door Block with three #8 x 1-1/4" Wood Screws. (F23.1, F23.2 and F23.3)

B: Tight to (1129) Top Door Block place one (1130) Door Block against both (1111) Left Door Post and (1112) Right Door Post, flush to the inside edges. Attach (1130) Door Blocks to each post with four #8 x 1-1/4" Wood Screws per board. (F23.1, F23.2 and F23.3)

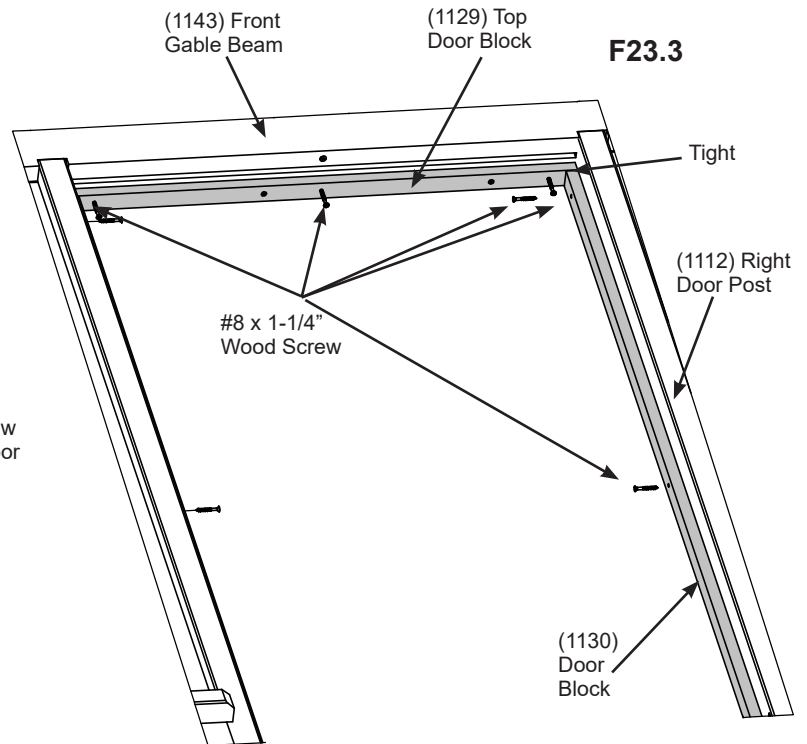
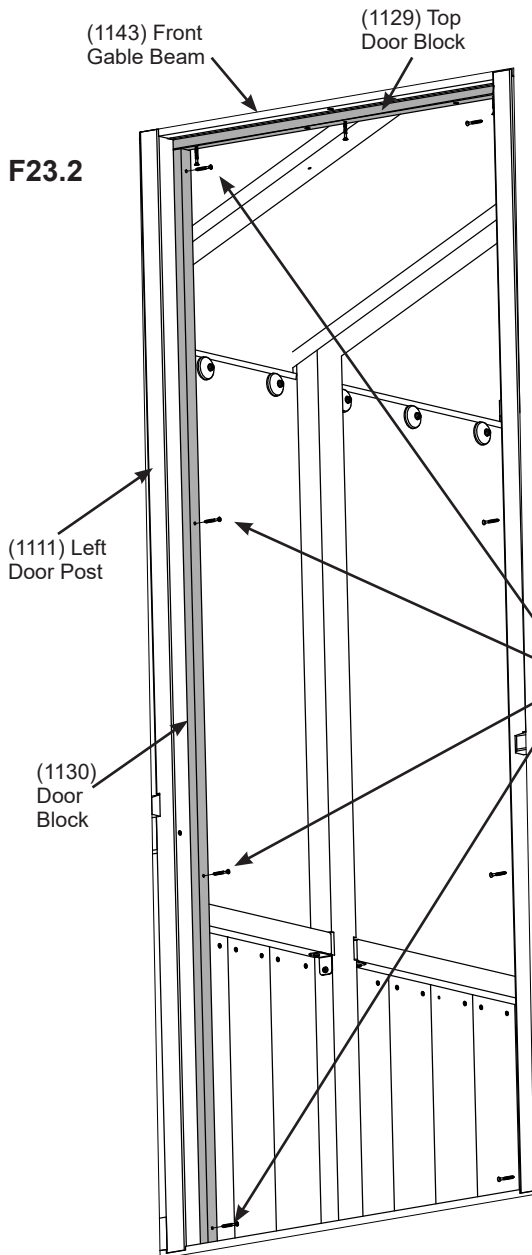
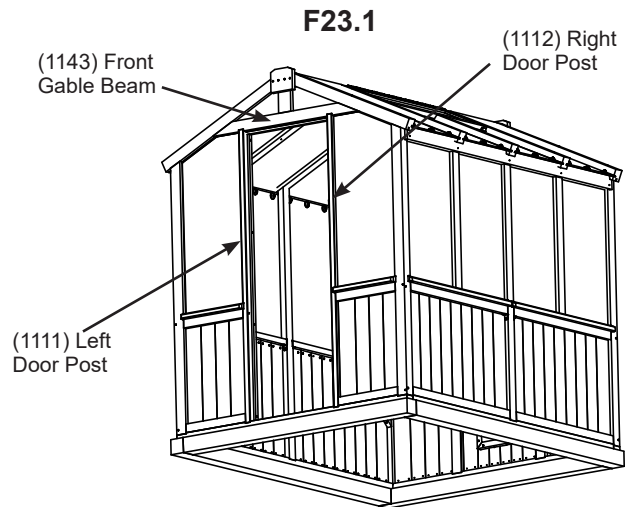

Wood Parts

- 1 x (1129) Top Door Block
- 2 x (1130) Door Block

Hardware

- 11 x #8 x 1-1/4" Wood Screw

Step 23: Door Assembly Part 2



Note: Door can be hung from either the right or left side. Instructions show from the left side. To hang from the right side Hinges and Sliding Barrel Bolt to be attached on the opposite side.

C: On the outside of the (1175) Door Panel measure 3" (7.62 cm) from the top and 3" (7.62 cm) from the bottom of the panel then attach two Square Hinges using three #7 x 3/4" Wood Screws per hinge. (F23.4 and F23.5)

D: On the same side as the top and bottom Square Hinges attach a third hinge centred on the panel using three #7 x 3/4" Wood Screws. (F23.4 and F23.5)

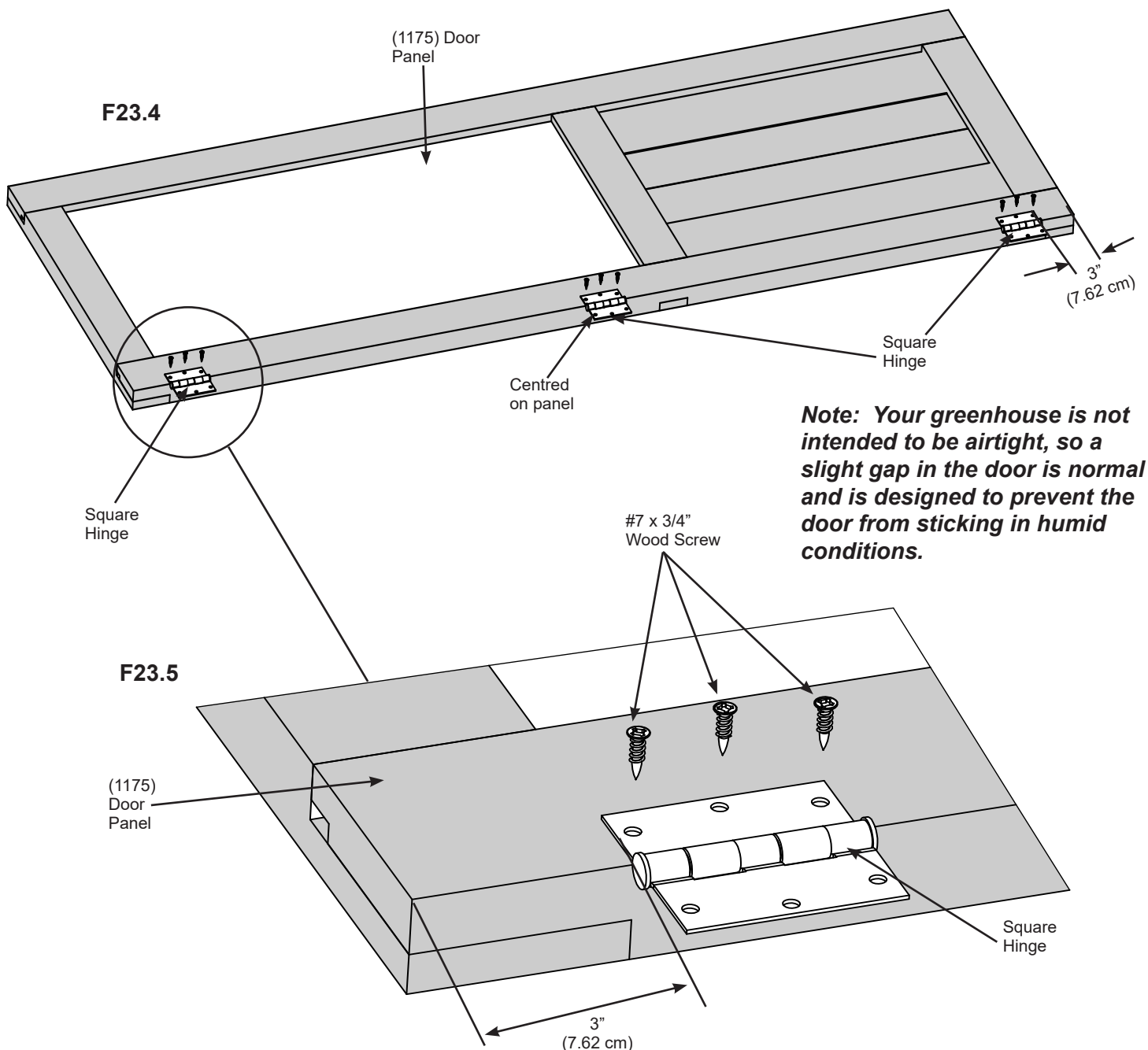

Wood Parts

1 x (1175) Door Panel

Components

3 x Square Hinges

Hardware

9 x #7 x 3/4" Wood Screw

Step 23: Door Assembly Part 3



E: Place (1188) Guide Spacers flat on Door Post and (1119) Front Base to set the space in the door opening for the (1175) Door Panel placement. (F23.6)

F: Place (1175) Door Panel in door opening and attach Square Hinges to Door Post with three #7 x 3/4" Wood Screws per hinge. Remove (1188) Guide Spacers. (F23.7 and F23.8)

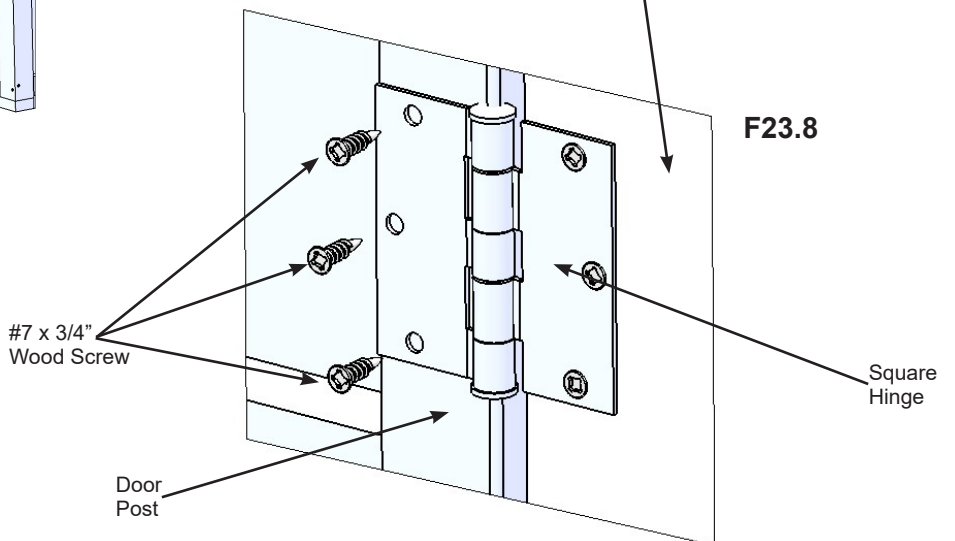
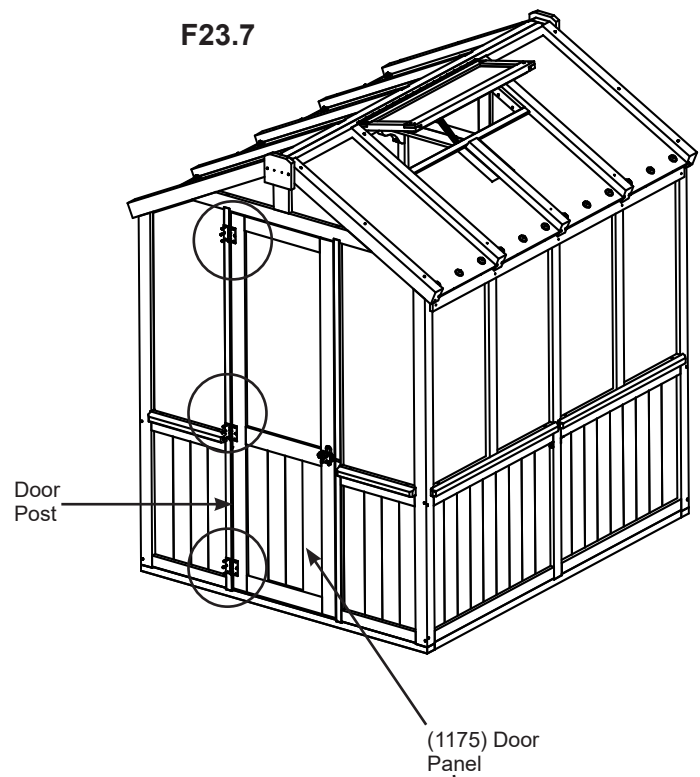
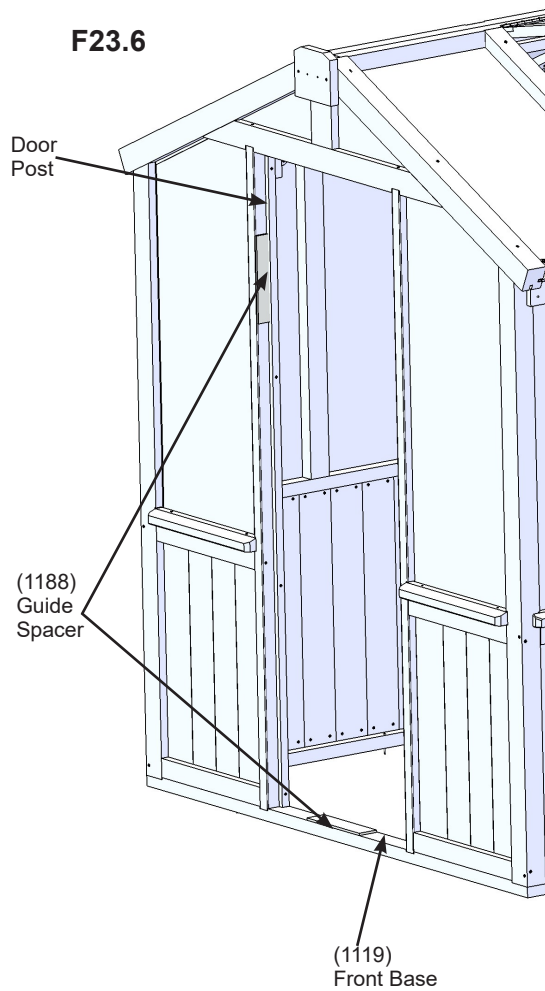

Hardware

9 x #7 x 3/4" Wood Screw

Step 23: Door Assembly Part 4



G: On the opposite side from the hinges, attach Sliding Barrel Bolt 1/4" (6.35 mm) to edge of (1175) Door Panel using three #10 x 1-1/4" Black Pan Screws, as shown in F23.9 and F23.10.

H: Close (1175) Door Panel to determine placement of the Ear of the Sliding Barrel Bolt on the Door Post then attach with two #10 x 1-1/4" Black Pan Screws. (F23.9 and F23.11)

F23.9

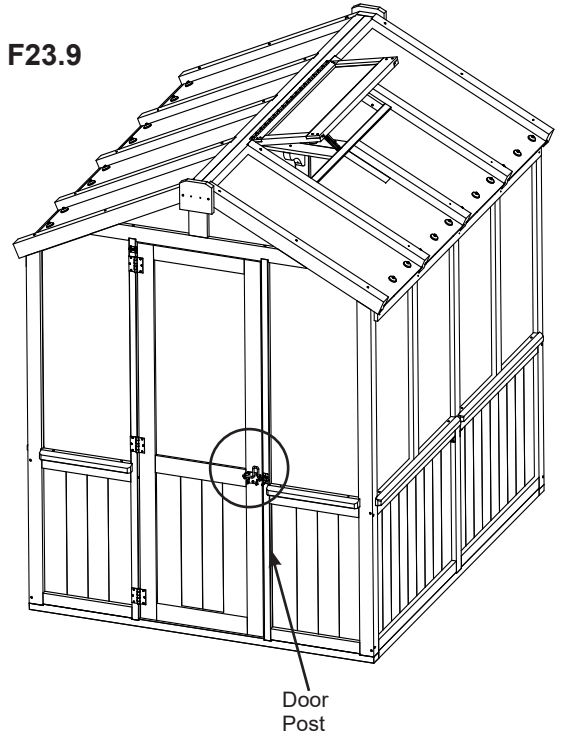

F23.10

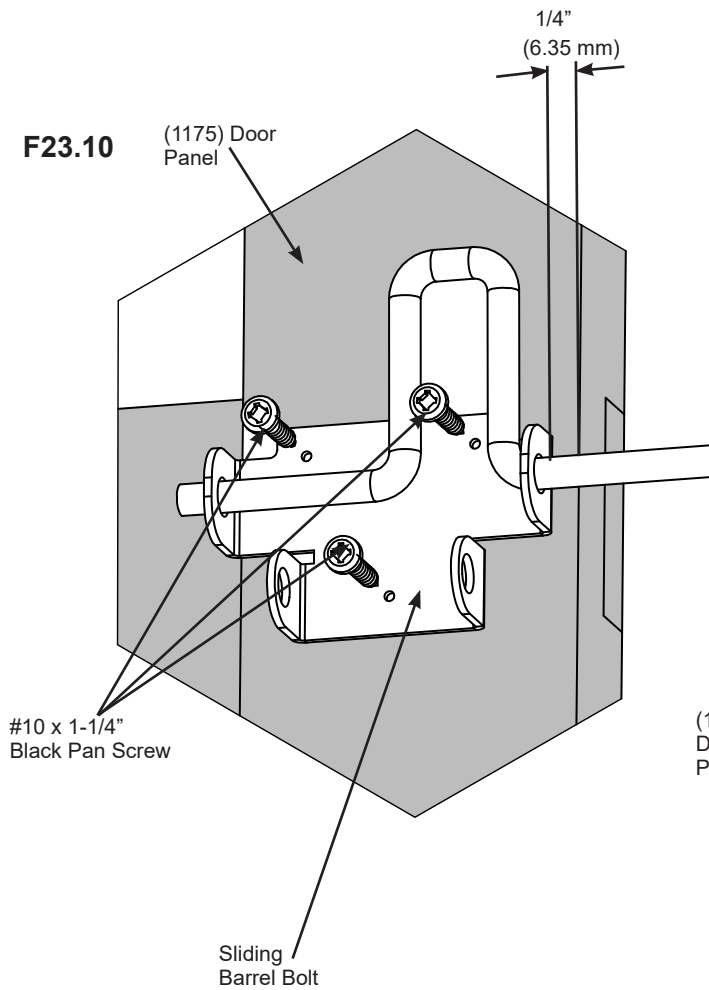

F23.11

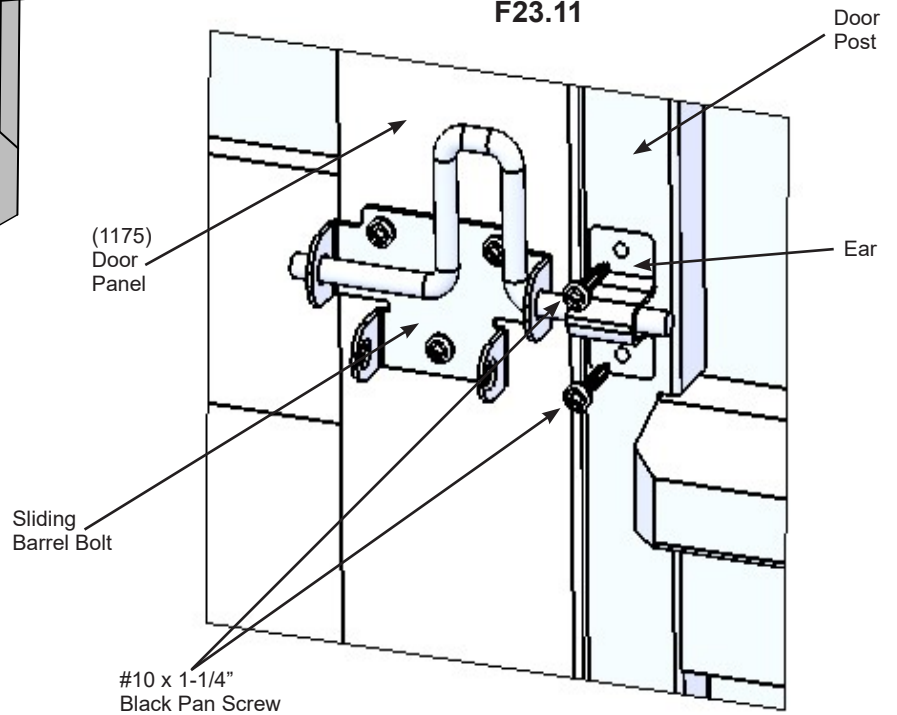

Components

1 x Sliding Barrel Bolt

Hardware

5 x #10 x 1-1/4" Black Pan Screw

Step 23: Door Assembly Part 5

I: Above the Sliding Barrel Bolt, at desired location, place Door Handle on (1175) Door Panel then attach using four #7 x 3/4" Wood Screws, (F23.12, F23.13 and F23.14)

F23.12

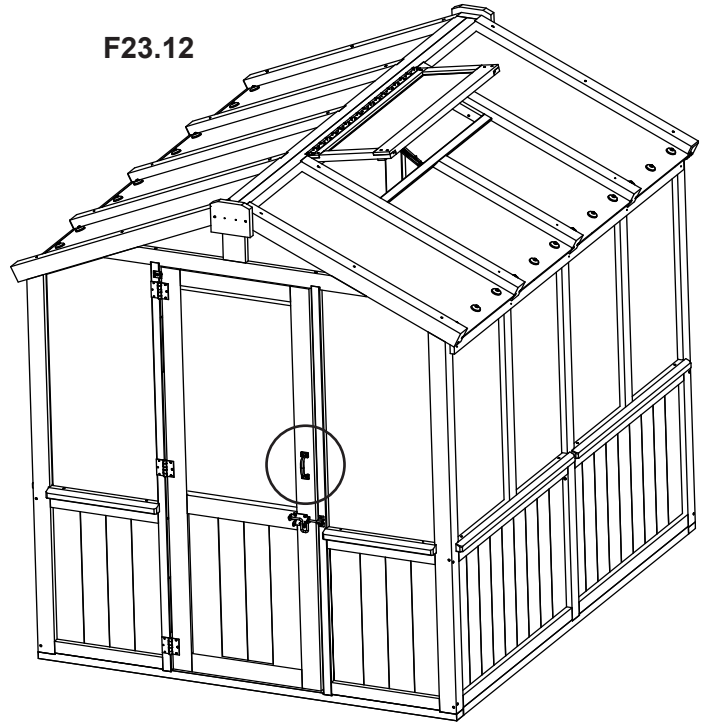

F23.13

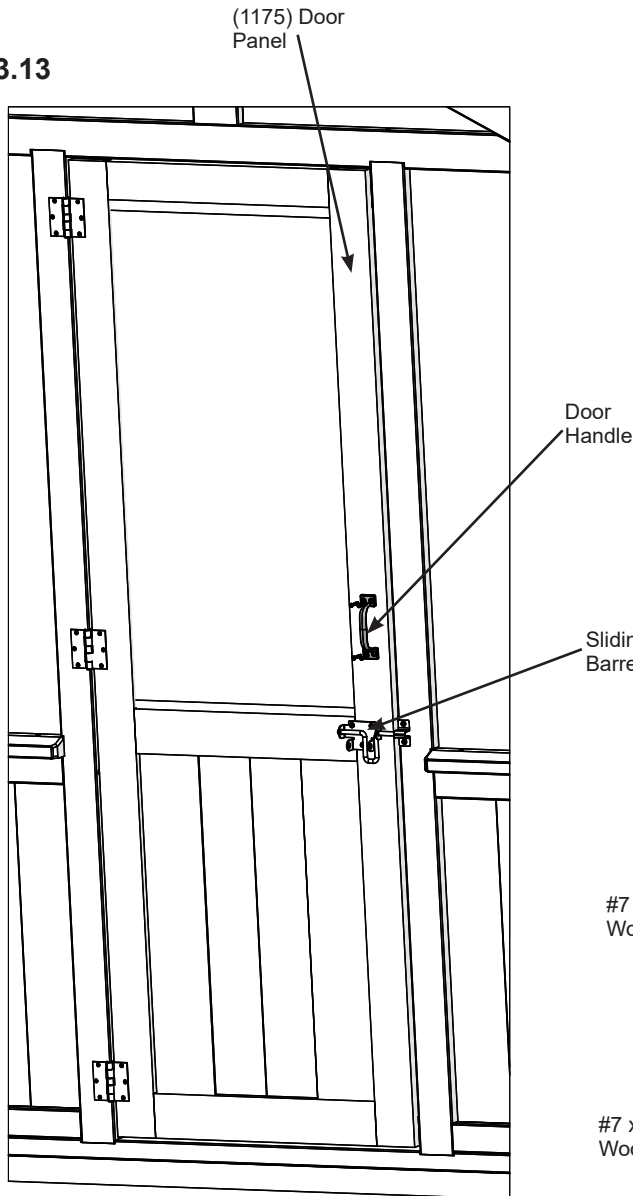

F23.14

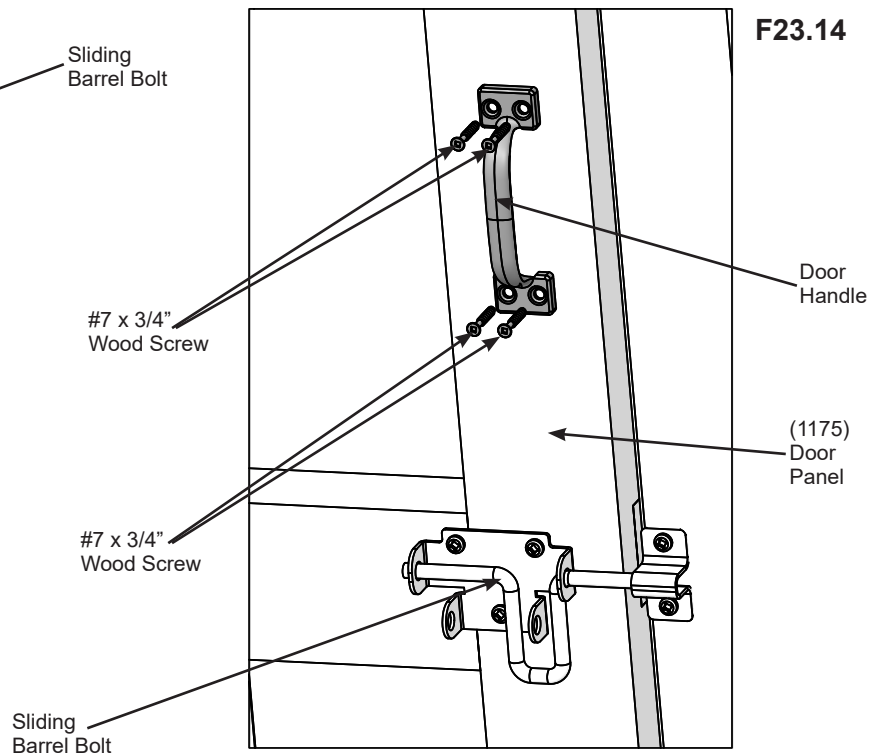

Components

1 x Door Handle

Hardware

4 x #7 x 3/4" Wood Screw

Step 24: Attach Closer Block

A: From inside the greenhouse, on the door side, with the door open, place (1142) Closer Block against Door Post and flush to outside edge of (1130) Door Block. The long side will be against (1130) Door Block and bottom of arch flush to the bottom of (1143) Front Gable Beam. Attach (1142) Closer Block to Door Post and (1143) Front Gable Beam with three #8 x 2-1/2" Wood Screws. (F24.1 and F24.2)

F24.1

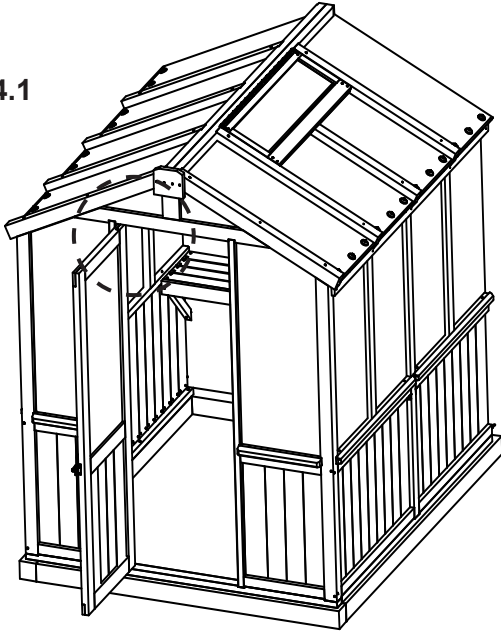

F24.2
Inside View

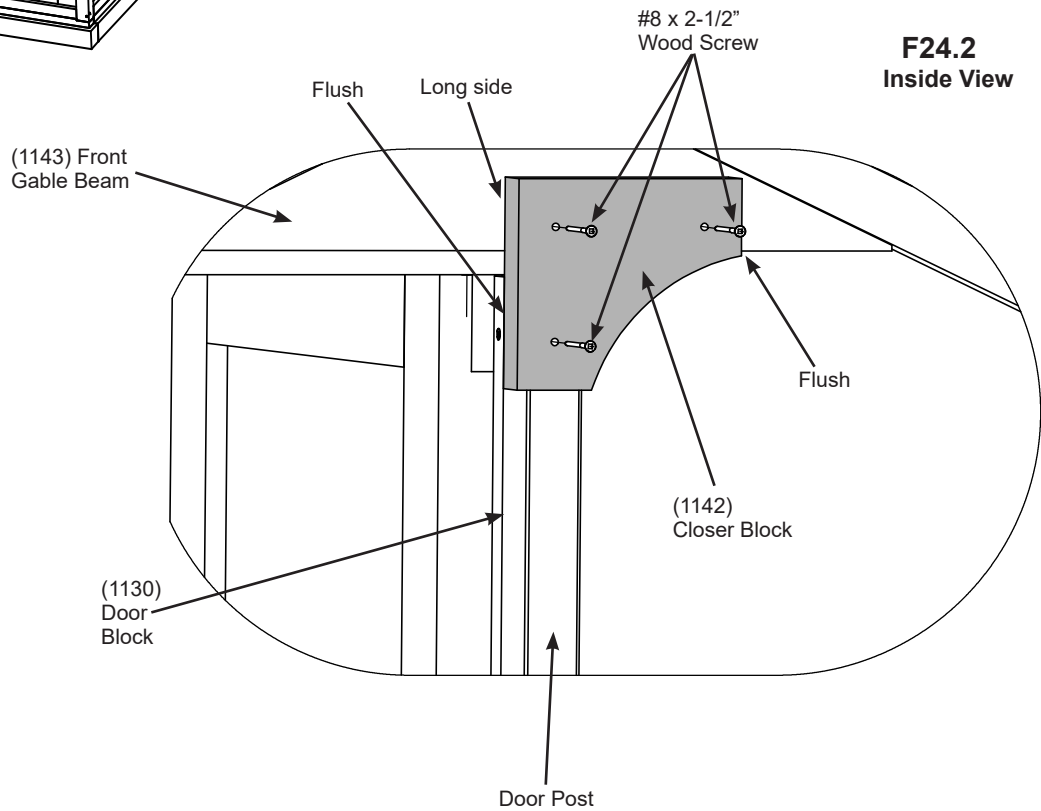

Wood Parts

1 x (1142) Closer Block

Hardware

3 x #8 x 2-1/2" Wood Screw

Step 25: Attach Door Closer Part 1

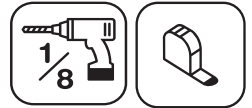

A: Measure 1" (2.54 cm) down from (1129) Top Door Block and 1/2" (1.27 cm) in from edge of (1142) Closer Block then place Bottom Tube Bracket on (1142) Closer Block and (1130) Door Block, pre-drill with a 1/8" drill bit then attach with four #10 x 1-1/4" Black Pan Screws. (F25.1)

F25.1

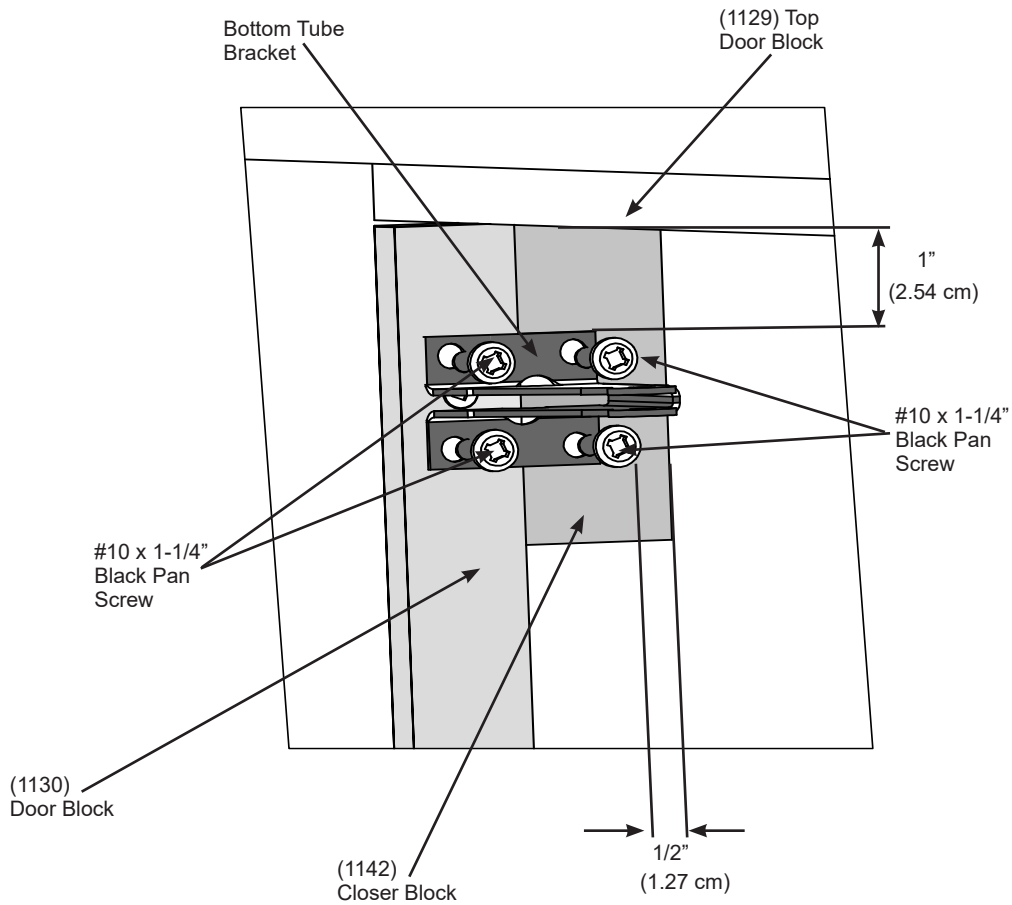

Components

1 x Bottom Tube Bracket

Hardware

4 x #10 x 1-1/4" Black Pan Screw

Step 25: Attach Door Closer Part 2

B: Slide 130° Angle Bracket over rod of the Tube then attach with Short Pin to Bottom Tube Bracket and attach a 12mm Ring. (F25.2 and F25.3)

C: Attach Top Tube Bracket to the end of the Tube with Long Pin and attach a 12mm Ring. (F25.3)

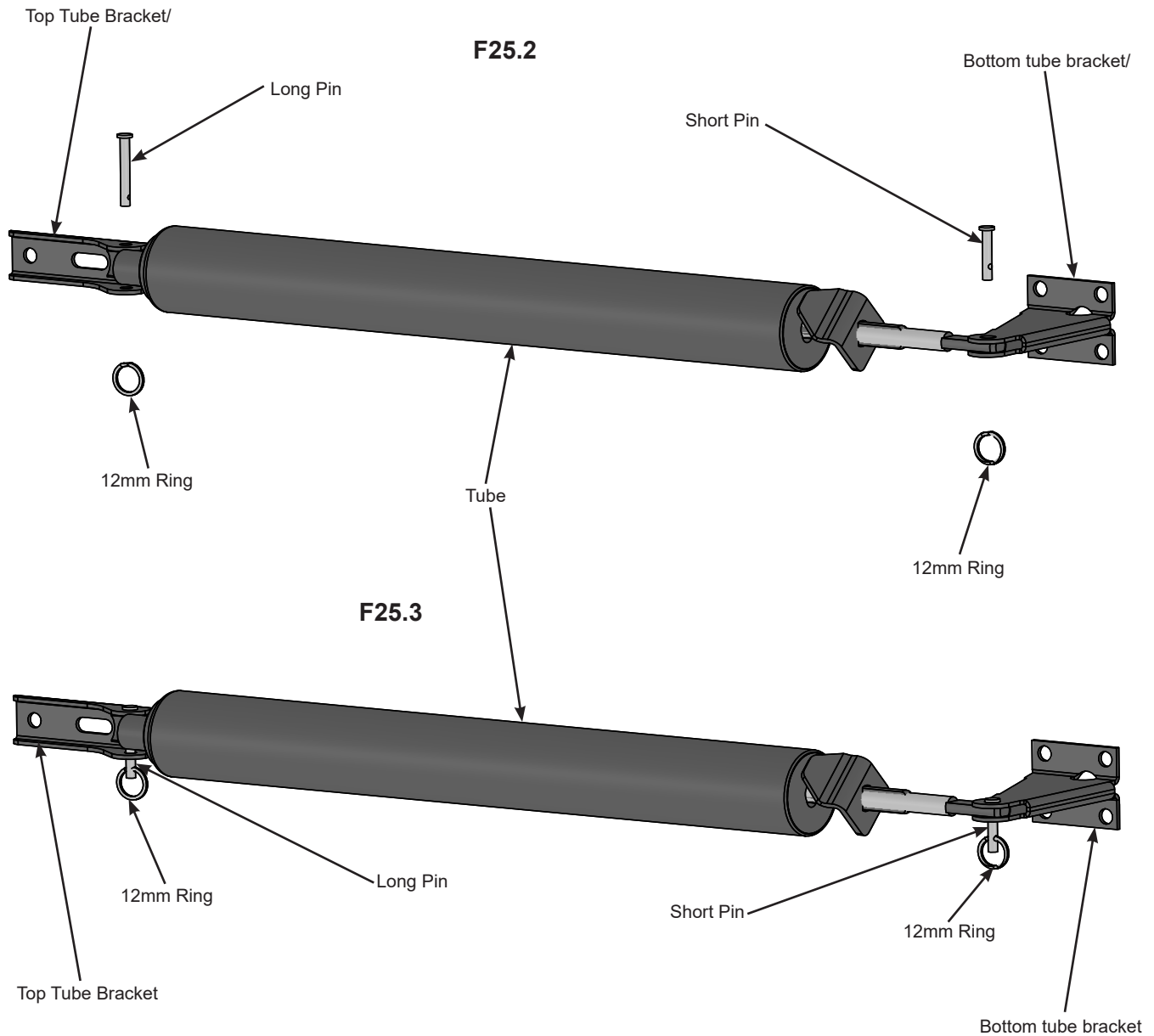

Components

2 x 12mm Ring	1 x Short Dowel
1 x Top Tube Bracket	1 x Long Dowel
1 x 130° Angle Bracket	1 x Tube

Step 25: Attach Door Closer Part 3

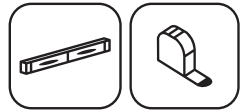

D: Close the door and place Top Tube Bracket on (1175) Door Panel so it measures 9" (22.9 cm) from the end of the panel. Attach with two #10 x 1-1/4" Black Pan Screws. Make sure tube is level. (F25.4 and F25.5)

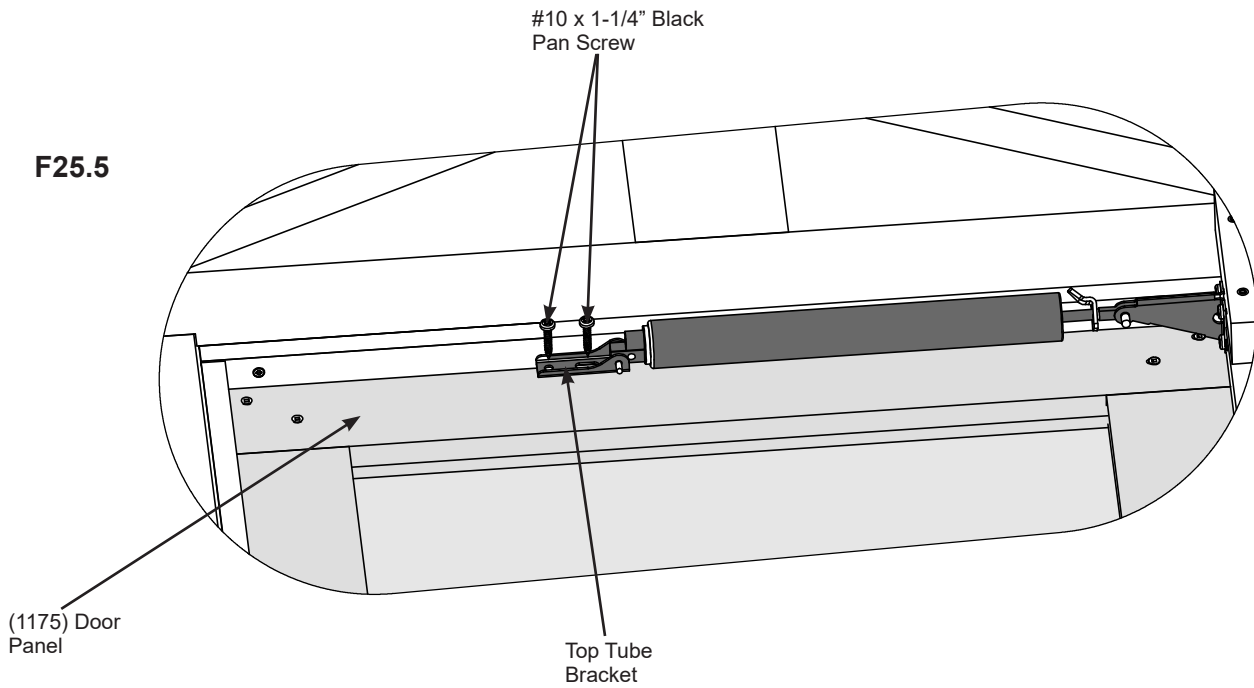
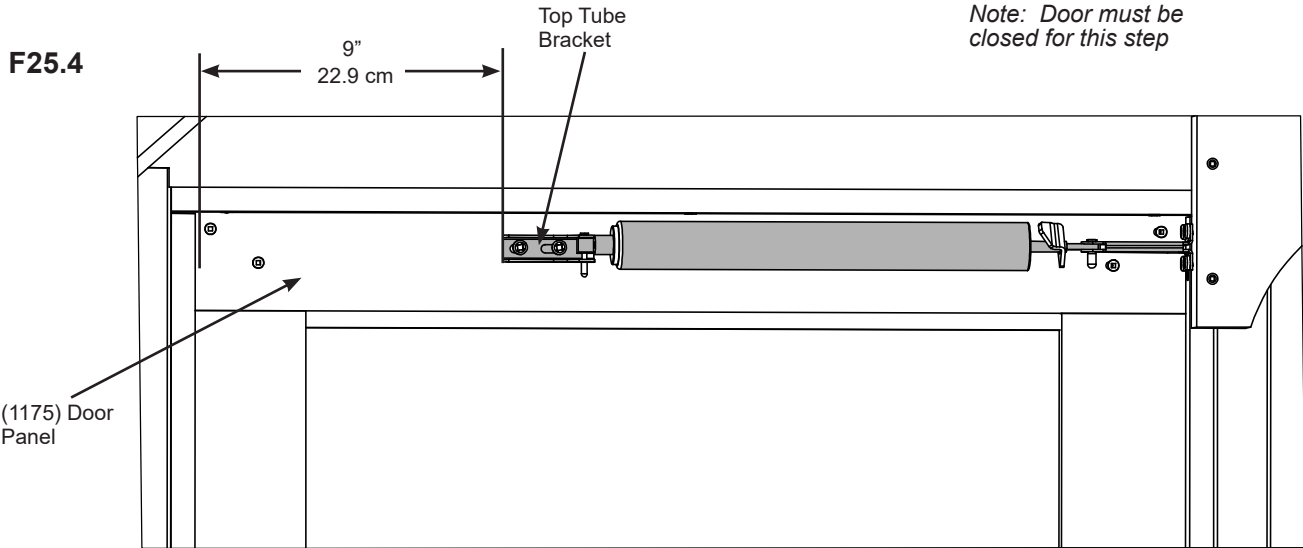

Hardware

2 x #10 x 1-1/4" Black Pan Screw

Step 25: Attach Door Closer Part 4



E: Open door, then along (1129) Top Door Block measure 8" (20.32 cm) in from (1130) Door Block and centred on (1129) Top Door Block pre-drill with a 1/8" drill bit. Put one #10 x 1-1/4" Pan Screw through end chain link then loosely attach to (1129) Top Door Block. Do not tighten screw, the chain needs to move easily. (F25.6)

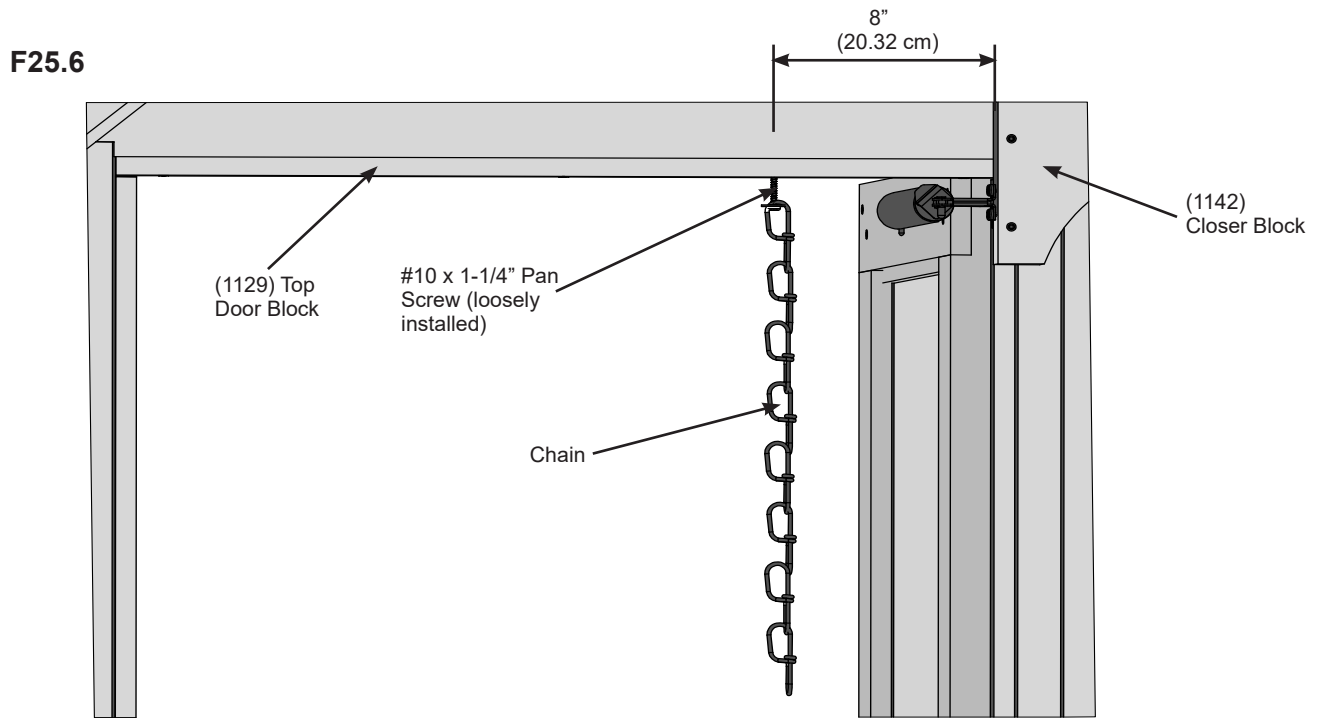

F: Measure 7" (17.8 cm) from end of (1175) Door Panel then attach Chain Bracket with two #10 x 1-1/4" Pan Screws. (F25.6 and F25.7)

G: To adjust the speed of the door, adjust the screw at the end of the tube. (F25.6 and F25.7)

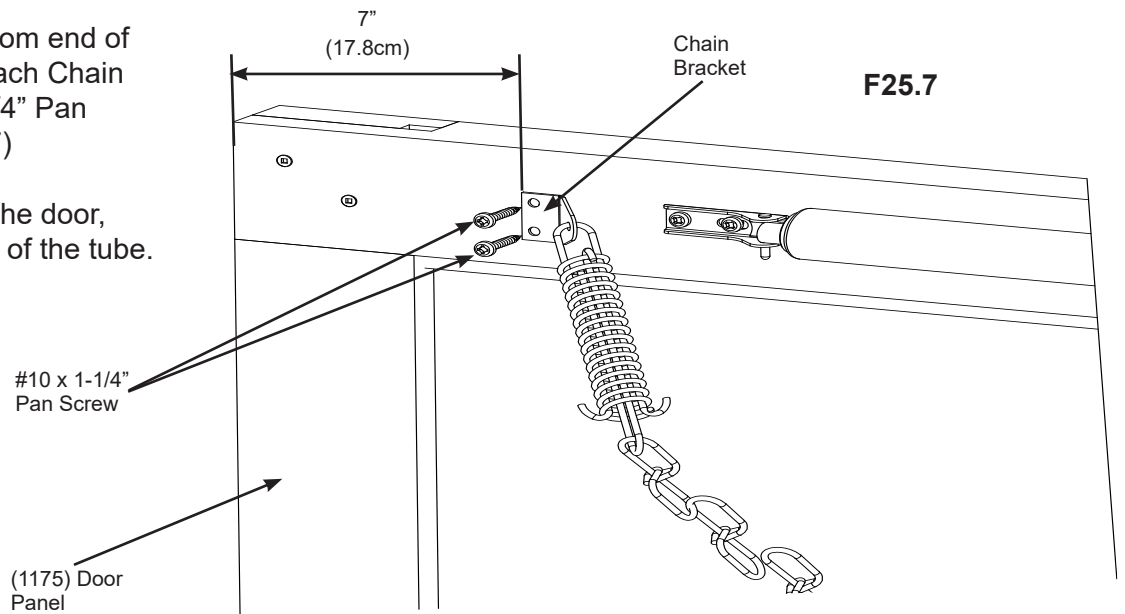

Components

1 x Chain with Chain Bracket

Hardware

3 x #10 x 1-1/4" Pan Screw

Step 26: Attach Eye Lags and Magnet Part 1

A: Attach one 3/8" Eye Lag to the pilot hole in each (1114) Middle Roof Rafter on both roof assemblies. (F26.1 and F26.2)

F26.1

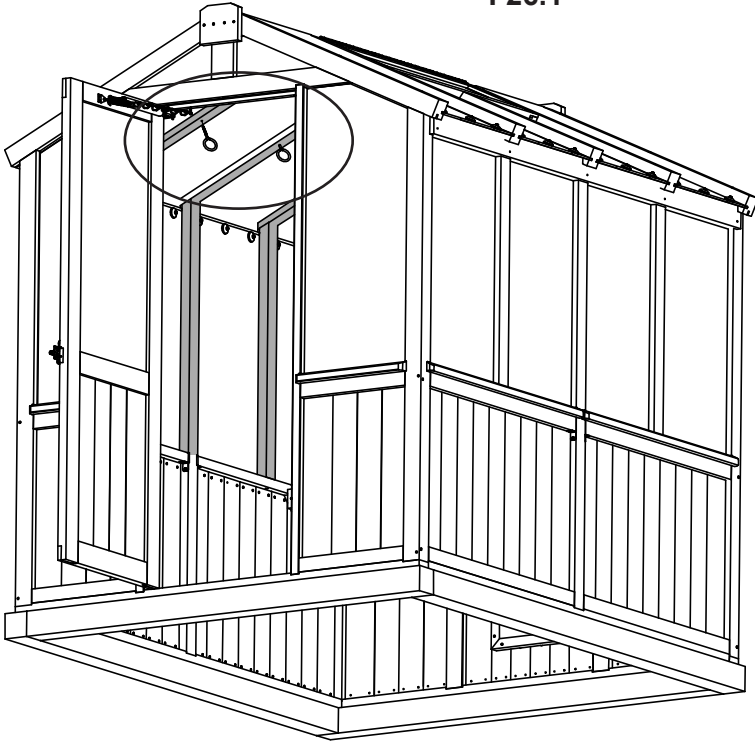

F26.2

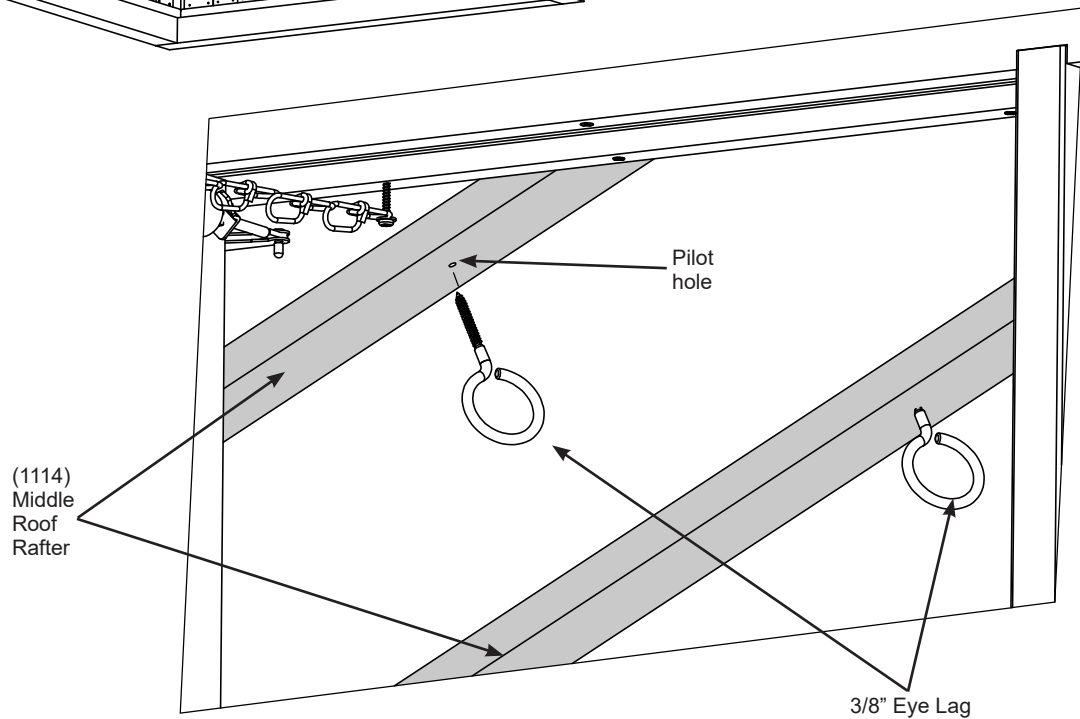

Components

5 x 3/8" Eye Lag

Step 26: Attach Eye Lags and Magnet Part 2

B: Install a magnet near the top and bottom of the (1130) Door Block with two #8 x 1/2" Pan Screws per Magnet. (F26.3 and F26.4)

C: Align Long Catch Plates to the Magnets then attach to Door Panel using two #7 x 3/4" Wood Screws per plate. (F26.3 and F26.5)

F26.3

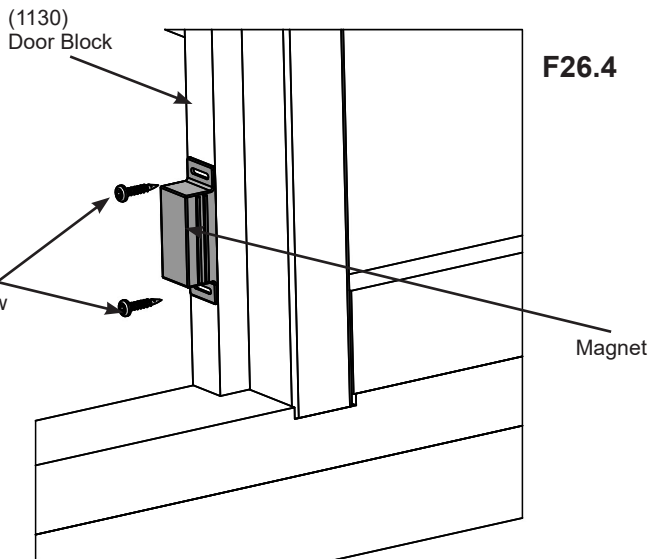
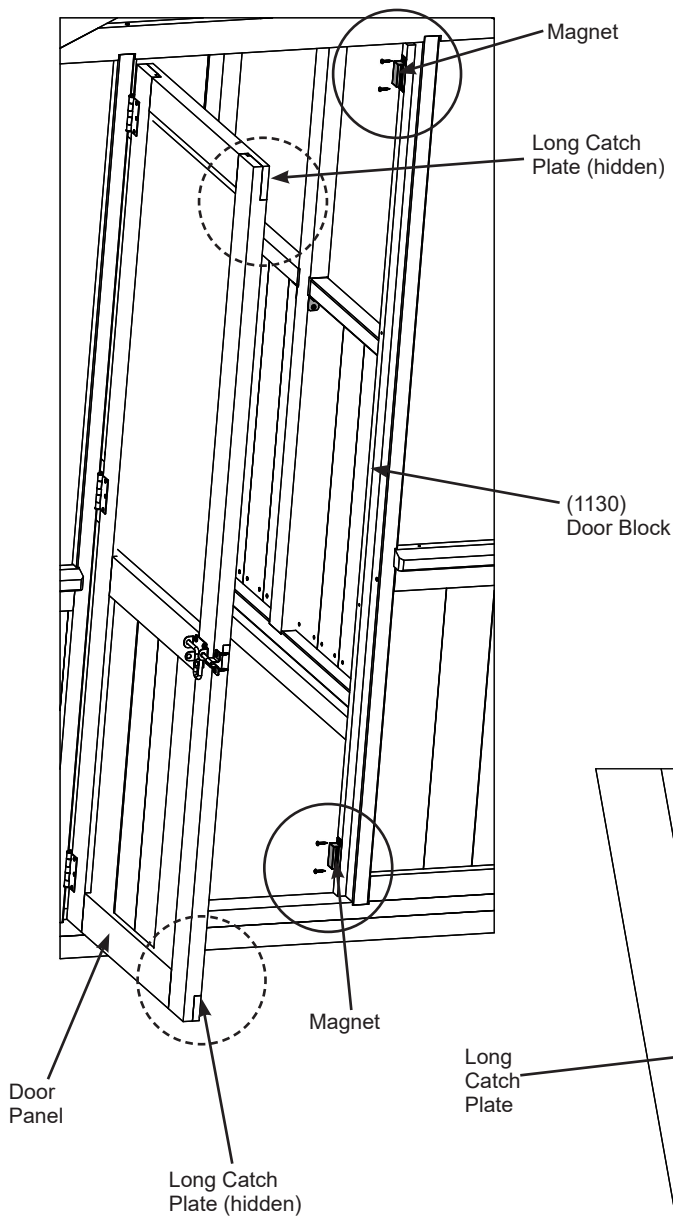

F26.5

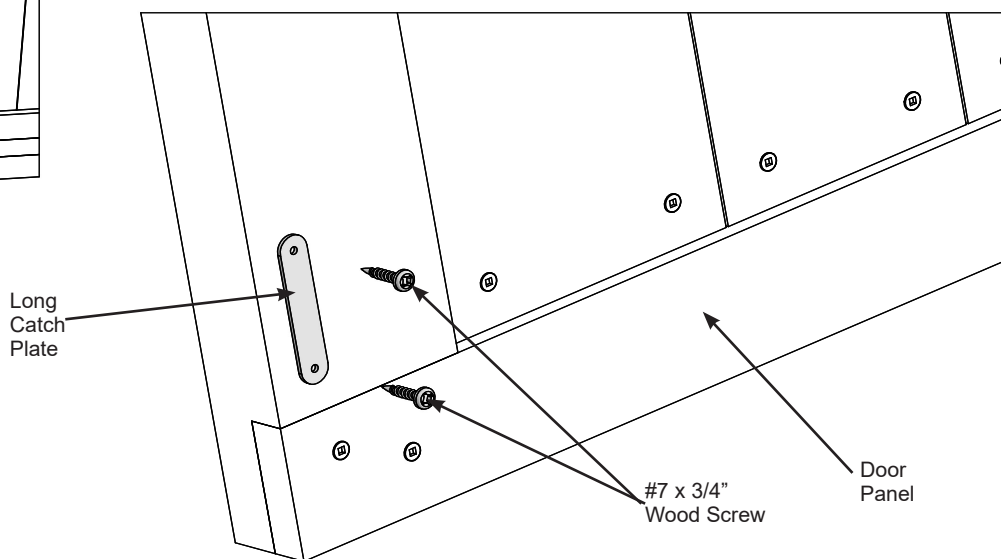

Components

- 2 x Magnet
- 2 x Long Catch Plate

Hardware

- 4 x #8 x 1/2" Pan Screw
- 4 x #7 x 3/4" Wood Screw

Step 27: Attach ID Plaque

A: Attach Gazebo ID Plaque to a prominent location on your greenhouse, such as inside the greenhouse above the door, with two #10 x 1-1/4" Pan Screws. This provides warnings concerning safety and important contact information. A tracking number is provided to allow you to get critical information or order replacement parts for this specific model. (F27.1 and F27.2)

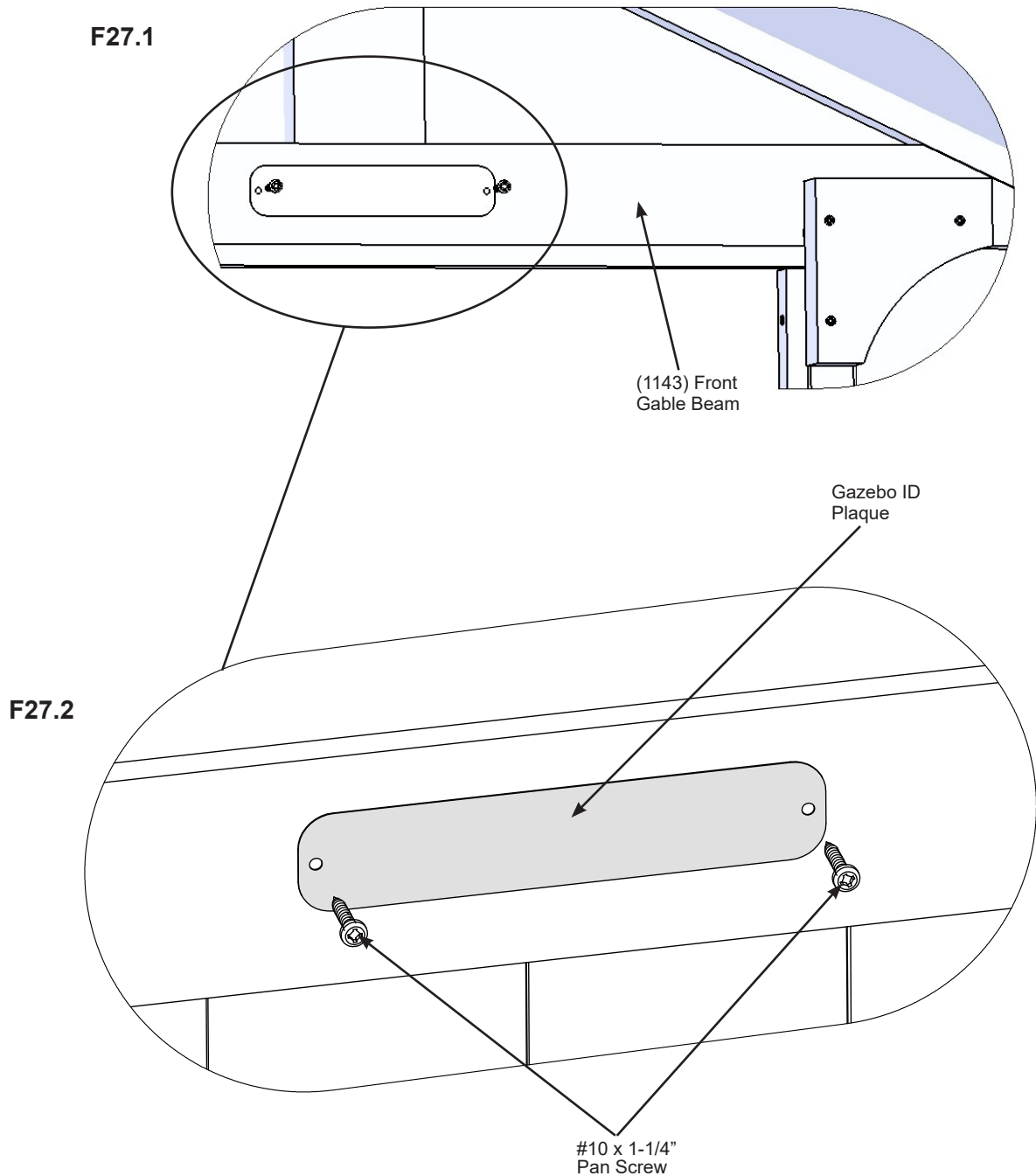

Components:

1 x Gazebo ID Plaque

Hardware

2 x #10 x 1-1/4" Pan Screw

Step 28: Install Vent Mesh

A: From inside the Greenhouse place Vent Mesh against (1170) Vent Roof Panel. Based on location of Female Snaps determine where Male Snaps should be located then install Male Snaps. (F28.1, F28.2 and F28.3)

B: Slide Single Spring Window Opener through hole in Vent Mesh then attach mesh to Male Snaps. (F28.1 and F28.4)

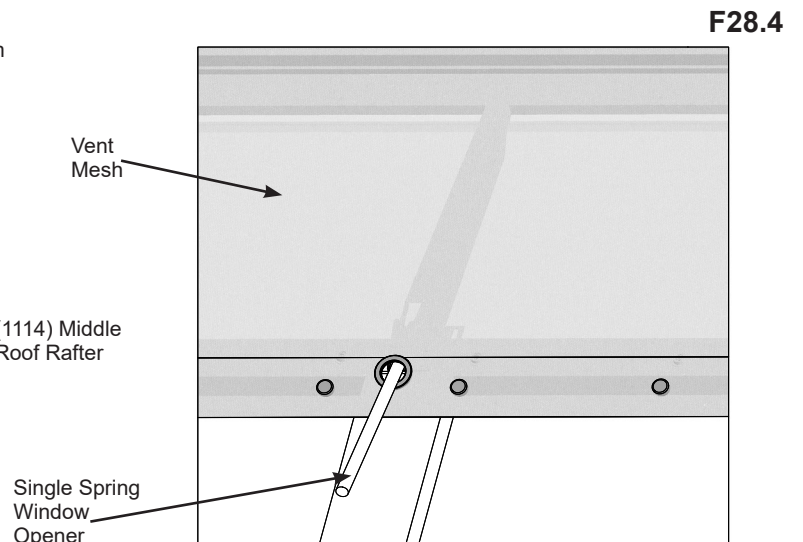
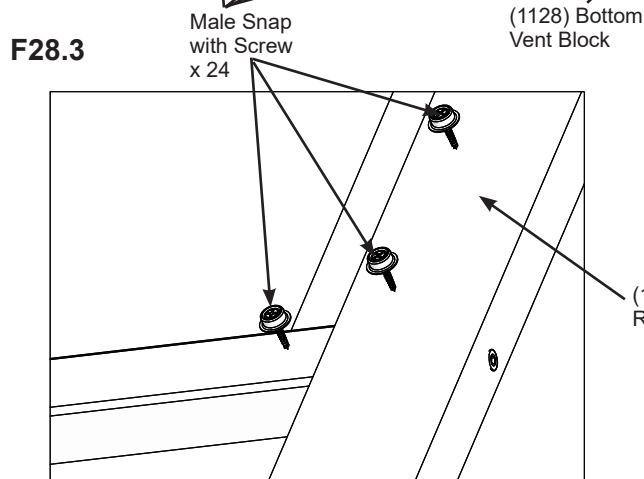
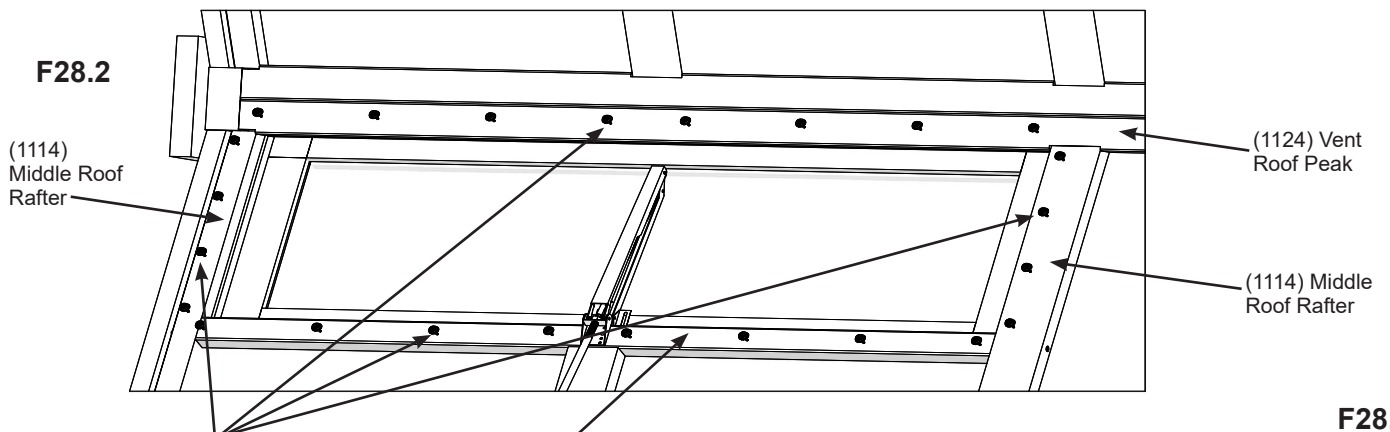
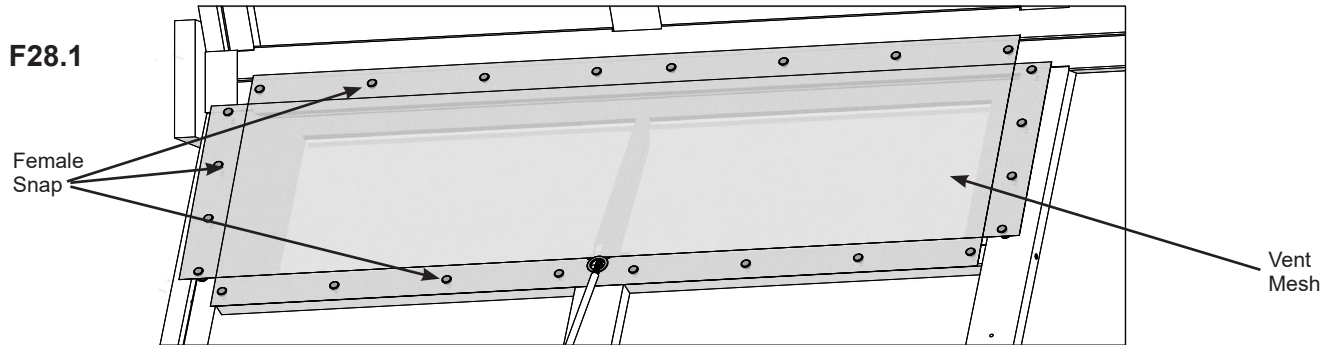

Components

1 x Vent Mesh

Hardware

24 x Male Snap with Screw



Customer Registration Card - Carte d'inscription du client - Tarjeta de Registro del Cliente

First Name - Prénom - Primer Nombre	Initial - Initiale - Inicial	Last Name - Nom de famille - Apellido

Street - Rue - Calle	PO Box - Boîte postale - Casilla postal	Apt. No. - App.

City - Ville - Ciudad	State/Province - État/Province - Estado/Provincia

ZIP/Postal Code - ZIP/Code postal - Código Postal	Country - Pays - País

E-mail Address - Adresse courriel - Dirección de E-mail	Telephone Number - N° de téléphone - No. de Teléfono

Model Name - Nom du modèle - Nombre del Modelo	Model Number (from front cover) - N° du modèle (page de couverture) - Número de Modelo (de la portada)

Date of Purchase - Date d'achat - Fecha de Compra (mm/dd/yyyy) (mm/jj/aaaa) (mm/dd/aaaa)	Place of Purchase - Lieu d'achat - Comprado a

Comments - Commentaires - Comentarios :

Mail To - Envoyer par courrier à - Enviar por Correo a:

Yardistry
375 Sligo Road West, PO Box 10
Mount Forest, Ontario, Canada, N0G 2L0
Attention: Consumer Relations
À l'attention de : Service à la clientèle
Atención a: Servicio de Atención al Cliente

Online Registration - Enregistrement en ligne - Registro online:

www.yardistrystructures.com/warranty

1.888.509.4382

Hours/ Heures/ Horas: 8:30 am - 5:00 pm EST
(excl. holidays/ hors jours fériés/ excepto los días festivos)

English and French Spoken / Anglais et français parlés / Inglés y francés hablado

Yardistry would like to say "Thank you" for your time and feedback.

Yardistry aimerait vous remercier d'avoir pris le temps de répondre au sondage.

Yardistry quiere "Agradecerle" por su tiempo y su opinión.