

4.9m x 4.9m (16' x 16') TIMBER FRAME GAZEBO

Installation and Operating Instructions – YM12875X

ITM. / ART. 1905256



IMPORTANT, RETAIN FOR FUTURE REFERENCE: READ CAREFULLY

Revised 04-15-2026

YARDISTRY®

Yardistry – North America
Toll Free Customer Support:
1.888.509.4382
info@yardistrystructures.com
www.yardistrystructures.com

Regular Hours: Mon - Fri, 8:30 am - 5:00 pm EST (excl. holidays)
(For extended hours see our website)
English and French Spoken

Patents Pending

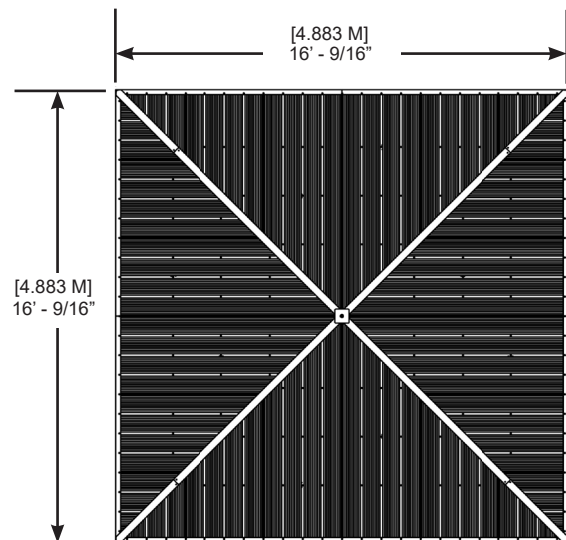

Height: 11' (3.35 m)

Important Safety Notice!

Yardistry components are intended for privacy, decorative and ornamental use only.

Product is NOT INTENDED for the following:

- A safety barrier to prevent unsupervised access to pools, hot tubs, spas or ponds.
- As load bearing support for a building, structure, heavy objects or swings.
- Used in structures that trap wind, rain or snow that would create extra load on the product.

Accumulated snow must be removed from roof.

DO NOT climb or walk on roof for any reason.

Permanent structures may require a building permit. As the purchaser and or installer of this product you are advised to consult local planning, zoning and building inspection departments for guidance on applicable building codes and/or zoning requirements.

Wood is NOT flame retardant and will burn. Grills, fire pits and chimineas are a fire hazard if placed too close to a Yardistry structure. Consult user's manual of the grill, fire pit or chiminea for safe distances from combustible materials.

Wear gloves to avoid injury from possible sharp edges of individual elements before assembly.

During installation, follow all safety warnings provided with your tools and use OSHA approved safety glasses. Some structures may require two or more people to install safely.

Check for underground utilities before digging or driving stakes into the ground!

During assembly it is important to closely follow the instructions. Complete the assembly on a solid, level surface and follow the instructions to square up, level and anchor the structure. This will reduce the gaps at wood connections during assembly.

General Information

General Information: Wood components are manufactured with Cedar (C. Lanceolata) which is protected with factory applied water-based stain. Knots, small checks (cracks) and weathering are naturally occurring and do not affect the strength of the product. Annual application of a water-based water repellent sealant or stain is important and will help reduce weathering and checks.

www.yardistrystructures.com

Questions?

Call toll free or write us at:
1 (888) 509-4382
support@yardistrystructures.com

Regular Hours: Mon - Fri, 8:30 am - 5:00 pm EST
(excl. holidays)
(For extended hours see our website)

English and French Spoken

Patents Pending

Limited Warranty

Yardistry warrants that this product is free from defect in materials and workmanship for a period of one (1) year from the original date of purchase. In addition, for any product with lumber, all lumber is warranted for five (5) years against rot and decay. This warranty applies to the original owner and registrant and is non-transferable.

Regular maintenance is required to assure the integrity of your product and is a requirement of the warranty. This warranty does not cover any inspection costs.

This Limited Warranty does not cover:

- Labor for replacement of any defective item(s);
- Incidental or consequential damages;
- Cosmetic defects which do not affect performance or integrity;
- Vandalism; improper use or installation; acts of nature, including but not limited to wind, storms, hail, floods, excessive water exposure;
- Minor twisting, warping, checking or any other natural occurring properties of wood that do not affect performance or integrity.

Yardistry products have been designed for safety and quality. Any modifications made to the original product could damage the structural integrity of the product leading to failure and possible injury. Yardistry cannot assume any responsibility for modified products. Furthermore, modification voids any and all warranties.

This product is warranted for RESIDENTIAL USE ONLY. Yardistry disclaims all other representations and warranties of any kind, express or implied.

This Warranty gives you specific legal rights. You may have other rights as well which vary from state to state or province to province. This warranty excludes all consequential damages, however, some states/provinces do not allow the limitation or exclusion of consequential damages, and therefore this limitation may not apply to you.

AUSTRALIA: Our goods come with guarantees that cannot be excluded under the Australian Consumer Law. You are entitled to a replacement or refund for a major failure and for compensation for any other reasonably foreseeable loss or damage. You are also entitled to have the goods repaired or replaced if the goods fail to be of acceptable quality and the failure does not amount to a major failure.

Instructions for Proper Maintenance

Your Yardistry structure is designed and constructed of quality materials. As with all outdoor products it will weather and wear. To maximize the enjoyment, safety and life of your structure it is important that you, the owner, properly maintain it.

HARDWARE:

- Check metal parts for rust. If found, sand and repaint using a non-lead paint complying with 16 CFR 1303.
- Inspect and tighten all hardware after completion of assembly; after first month of use; and then annually. Do not over-tighten as to cause crushing and splintering of wood.
- Check for sharp edges or protruding screw threads, add washers if required.

WOOD PARTS:

- Applying a water repellent or stain (water-based) on a yearly basis is important maintenance to maintain maximum life and performance of the product.
- Check all wood members for deterioration, structural damage and splintering. Sand down splinters and replace deteriorated wood members. As with all wood, some checking and small cracks in grain is normal.
- Some gapping may occur at some wood connections.

Assembly Guides

Tools Required:

- | | | |
|------------------------------|---------------------|----------------------|
| • Tape Measure | • 8' Step Ladder x2 | • 6' Step Ladder x 2 |
| • Carpenters Level | • Safety Glasses | • Square |
| • Standard or Cordless Drill | • Adult Helper | • Ratchet |
| • 7/16", 1/2" & 9/16" Wrench | • Safety Gloves | • Claw Hammer |
| • 7/16", 1/2" & 9/16" Socket | • Hard Hat | |

Symbols:

Throughout these instructions symbols are provided in the top, right-hand corner of the page.



- Use Help, where this is shown, 2, 3 or 4 people are required to safely complete this step. To avoid injury or damage to the assembly make sure to get some help.



- Use a measuring tape to ensure proper location



- Pre-drill a pilot hole before fastening screw or lag to prevent splitting of wood.



- Check that assembly is square before tightening bolts

If you dispose of your Yardistry structure: Please disassemble and dispose of your unit so that it does not create any unreasonable hazards at the time it is discarded. Be sure to follow your local waste ordinances.

Assembly Tips

Following are some helpful tips to make the assembly process smooth and efficient.

PRE-ASSEMBLIES:

(i.e. Post and Beam Assemblies, Roof Rafter Assembly, etc)

- Work on a raised, solid and flat surface such as, a table or saw horse.
- Keep all connections flush where shown in the instructions.
- When assembling the beams keep parts flat, straight and snug when connecting.

METAL PARTS:

- Roofing material may have sharp edges, wear safety gloves.
- Remove all plastic covering, on both sides of the metal panels, directly before installing each piece.
- Place roofing material on a non-abrasive surface before and after assembly as it can bend, dent and scratch easily.
- The roofing screws can easily crush the roof panels and roof edges when using a power drill. We recommend hand tightening the roofing screws so they sit snug and tight to the roofing material.

Permanent Installation Examples

Note: It is critically important you start with square, solid and level footings, concrete pad or deck to attach your Pavilion.

We supply Post Mounts with this structure which gives you the flexibility to permanently install your structure to a pre-existing or new wood or concrete surface.

- The hardware to attach the Post Mount to the structure is included.
- The hardware to mount the structure permanently will need to be purchased separately at your local hardware store.

If you are mounting to concrete footers see below for the correct locations and placement. Please double check for possibility of any underground utilities such as gas, telephone, cable or sprinkler lines.

Following are some examples of how to mount the structure to wood or concrete surfaces.

Refer to your local building and city codes, ordinances, neighbourhood covenants, or height restrictions regarding this type of structure for guidance on acceptable installation requirements.

Concrete Footer

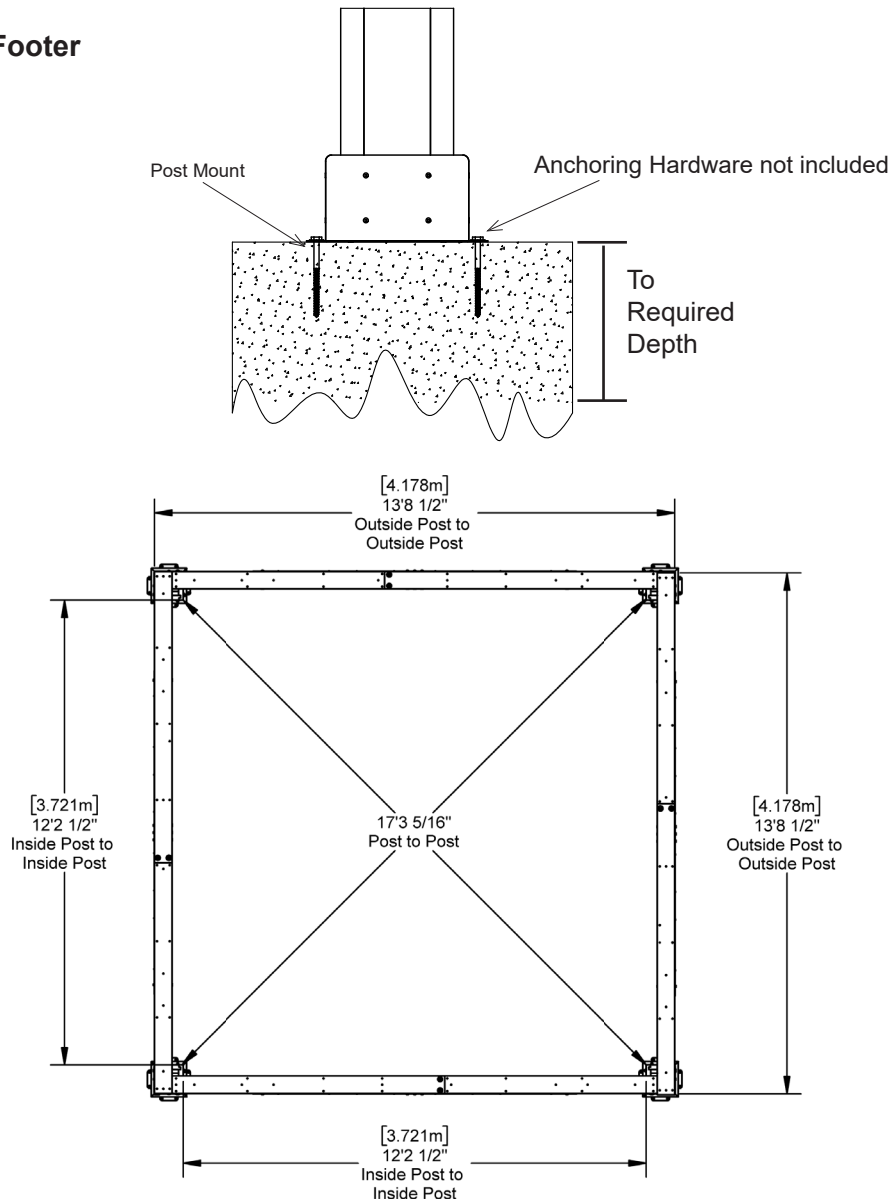

Permanent Installation Examples cont.

Concrete Patio 4.483m x 4.483m (14' 8-1/2" x 14' 8-1/2") with 15.24cm (6") clearance on all sides

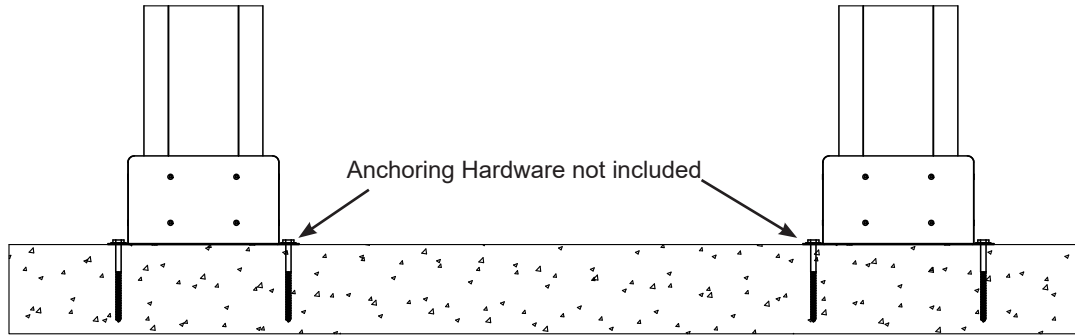

Concrete Patio 4.483m x 4.483m (14' 8-1/2" x 14' 8-1/2") with 15.24cm (6") clearance on all sides

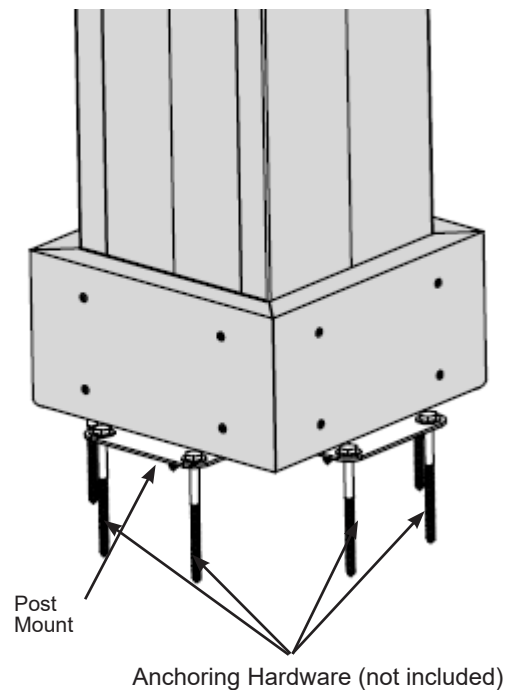
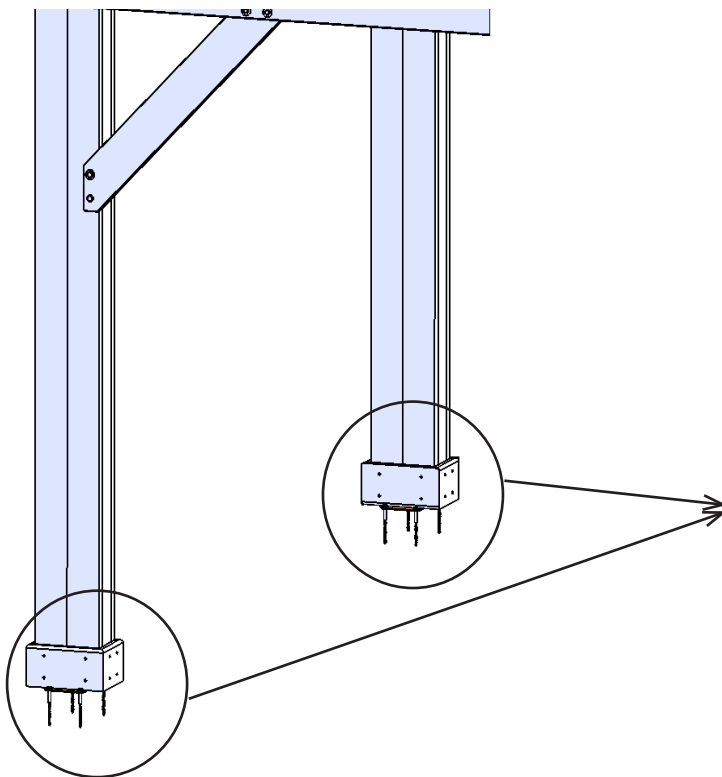
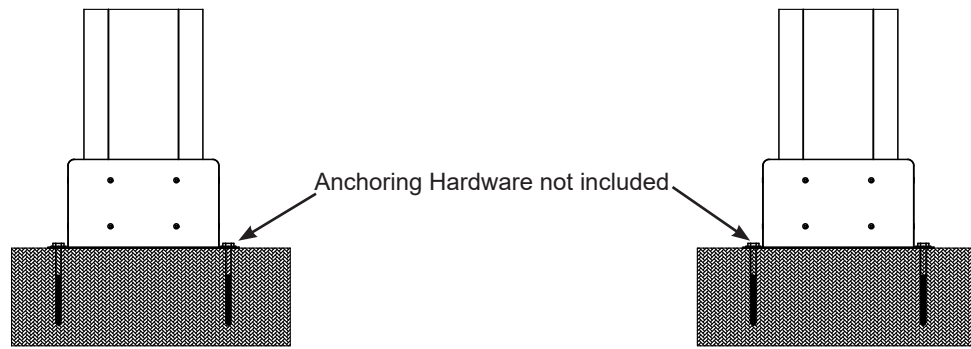

Post Mounts have a 12.7mm (1/2") diameter hole for anchoring hardware.

Part Identification (Dimensions are approximate and are shown to assist in the identification of parts for assembly. Actual dimensions may be smaller or larger.)

4pc. (2038) - 9x9 Post 2438.4mm (96") FSC



8pc. (1468) - Gusset Side 987.5mm (38-7/8") FSC

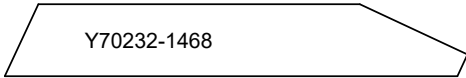

16pc. (1465) - Plinth 282.5mm (11-1/8") FSC

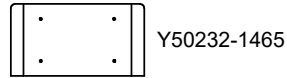

4pc. (1473) - Beam Block 24" 609.6mm (24") FSC

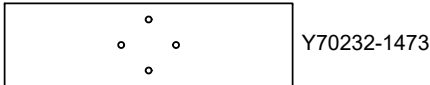

8pc. (2048) - Beam Block 9" 228.6mm (9") FSC

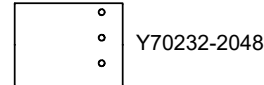

8pc. (1472) - Beam Block 17" 431.8mm (17") FSC



2pc. (2044) - HB Top LT 1784.3mm (70-1/4") FSC

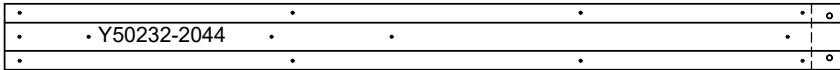

2pc. (1460) - Beam Top LT 1924.1mm (75-3/4") FSC

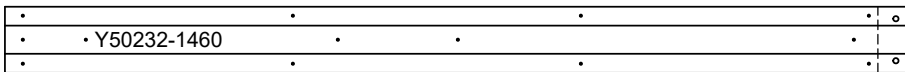

2pc. (2045) - HB Top RT 2190.8mm (86-1/4") FSC

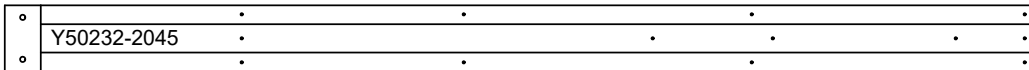

2pc. (1459) - Beam Top RT 2330.5mm (91-3/4") FSC

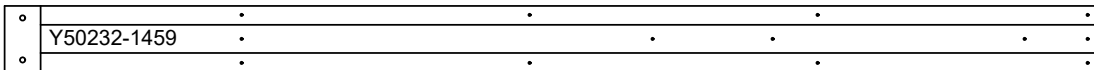

4pc. (2043) - HB Back End 768.4mm (30-1/4") FSC

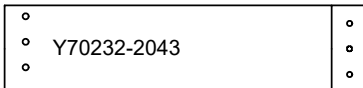

4pc. (2049) - HBL Back End 908.1mm (35-3/4") FSC

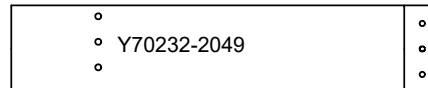

4pc. (1495) - Beam Back Center 2514.6mm (99") FSC

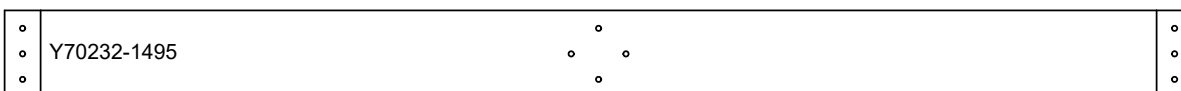

Part Identification (Dimensions are approximate and are shown to assist in the identification of parts for assembly. Actual dimensions may be smaller or larger.)

2pc. (2039) - HB Front LT 1987.6mm (78-1/4") FSC



2pc. (2040) - HB Front RT 1987.6mm (78-1/4") FSC



2pc. (2041) - HBL Front LT 2127.3mm (83-3/4") FSC



2pc. (2042) - HBL Front RT 2127.3mm (83-3/4") FSC



4pc. (2047) - HB Bottom End 730.3mm (28-3/4") FSC

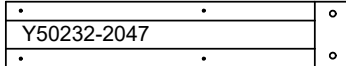

4pc. (1462) - Beam Bottom End 870mm (34-1/4") FSC

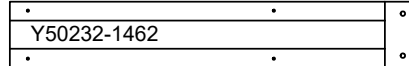

4pc. (1461) - Beam Bottom Center 2590.8mm (102") FSC

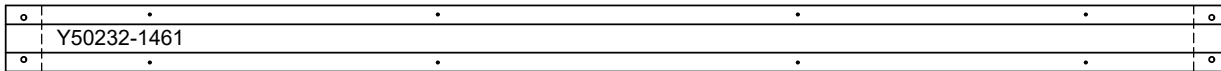

4pc. (2022) - Fascia End Left 2452.9mm (96-9/16") FSC



4pc. (2023) - Fascia End Right 2452.9mm (96-9/16") FSC

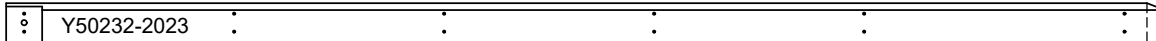

4pc. (2591) - Corner Rafter Left A 1311.4mm (51-5/8") FSC

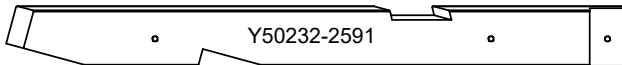

4pc. (2593) - Corner Rafter Left B 2240.5mm (88-1/4") FSC

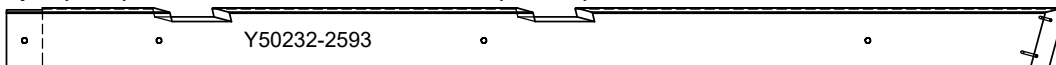

4pc. (2592) - Corner Rafter Right A 2588.7mm (101-15/16") FSC

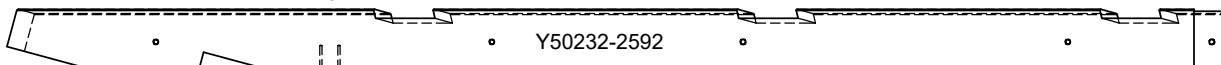

Part Identification (Dimensions are approximate and are shown to assist in the identification of parts for assembly. Actual dimensions may be smaller or larger.)

4pc. (2596) - Strap Right Short 889.8mm (35") FSC

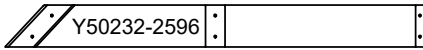

1pc. (2440) - Post Block 148mm (5-13/16") FSC



4pc. (2597) - Strap Left Short 1413.5mm (55-11/16") FSC

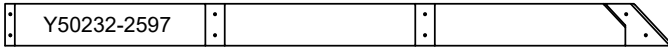

4pc. (2598) - Strap Right Long 2303.2mm (90-11/16") FSC

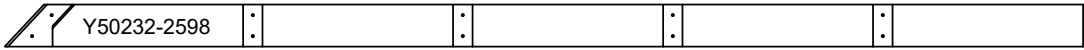

4pc. (2594) - Corner Rafter Right B 963.2mm (37-15/16") FSC



4pc. (2589) - Rafter Left D 626.3mm (24-5/8") FSC

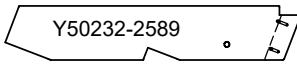

4pc. (2587) - Rafter Left C 1108.9mm (43-11/16") FSC



4pc. (2585) - Rafter Left B 1585mm (62-7/16") FSC

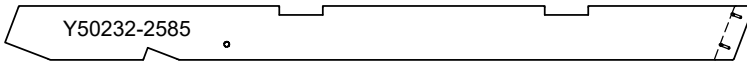

4pc. (2582) - Rafter Left A 2061.2mm (81-3/16") FSC

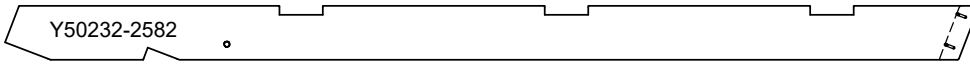

4pc. (2581) - Rafter Center 2555mm (100-9/16") FSC

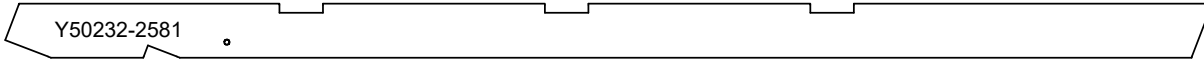

4pc. (2590) - Rafter Right D 626.3mm (24-5/8") FSC

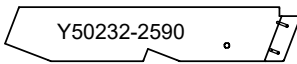

4pc. (2588) - Rafter Right C 1108.9mm (43-11/16") FSC



4pc. (2586) - Rafter Right B 1585mm (62-7/16") FSC

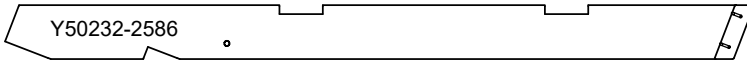

4pc. (2583) - Rafter Right A 2061.2mm (81-3/16") FSC

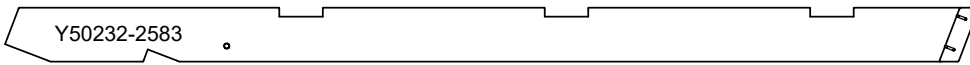

4pc. (2584) - Strap 1618mm (63-3/4") FSC

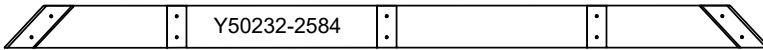

4pc. (2595) - Strap Left Long 1778.8mm (70") FSC

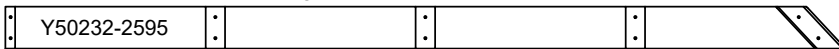

Hardware Identification (Dimensions are approximate and are shown to assist in the identification of parts for assembly. Actual dimensions may be smaller or larger.)

36pc. 1/4 x 2-1/2" Hex Bolt - (Y07718-222)

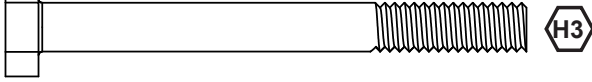

4pc. Lag Screw (1/4" Shank) 5/16 x 3" - (Y06218-330)

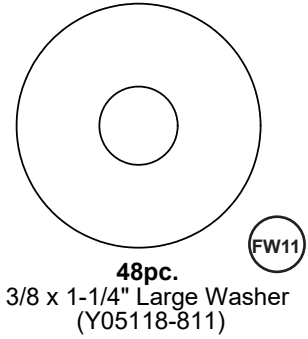
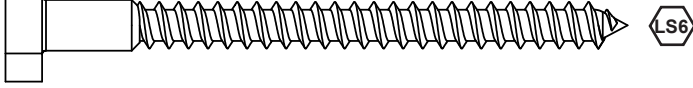

24pc. Lag Screw 5/16 x 4-3/4" - (Y06218-343)

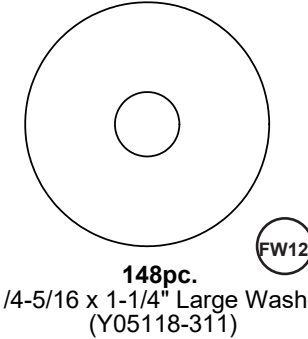
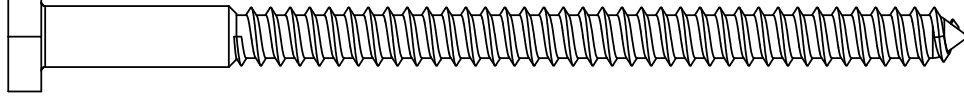

28pc. Hex Bolt 5/16 x 1" - (Y07718-310)



16pc. Lag Screw 5/16 x 2-1/2" - (Y06218-322)

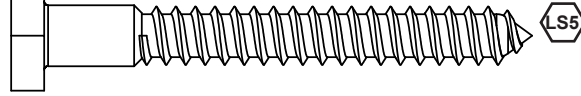

44pc. Hex Bolt 5/16 x 1-1/2" - (Y07718-312)

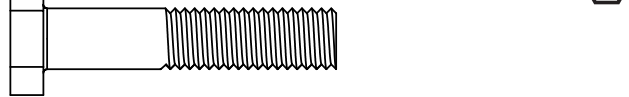

2pc. Hex Bolt 5/16 x 1-3/4" - (Y07718-313)

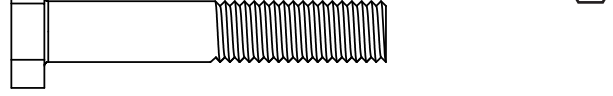

24pc. - 3/8" Lock Nut (Y08318-803)

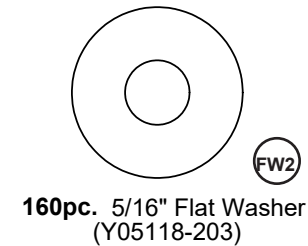
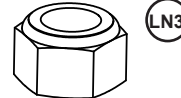

2pc. Hex Bolt 5/16 x 2" - (Y07718-320)

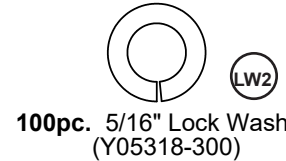
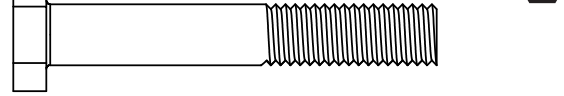

10pc. Hex Bolt 5/16 x 3-1/4" - (Y07718-331)

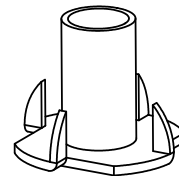
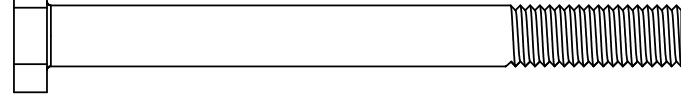

20pc. Hex Bolt 5/16 x 3-3/4" - (Y07718-333)

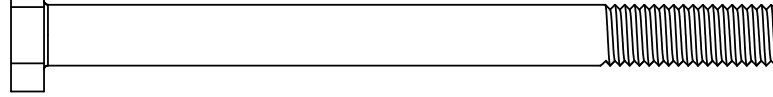

32pc. Hex Bolt 5/16 x 5-3/4" - (Y07718-353)

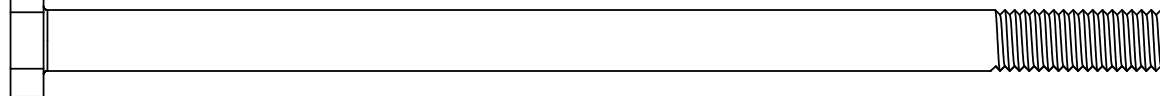

8pc. Hex Bolt 5/16 x 6-1/4" - (Y07718-361)

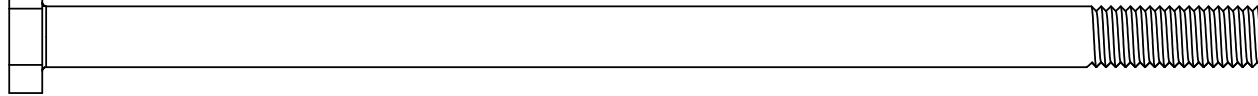

Hardware Identification (Dimensions are approximate and are shown to assist in the identification of parts for assembly. Actual dimensions may be smaller or larger.)

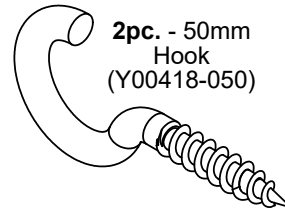
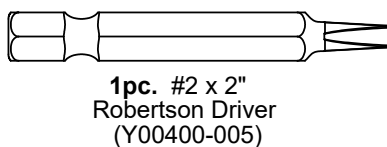
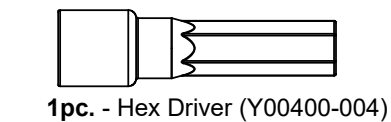
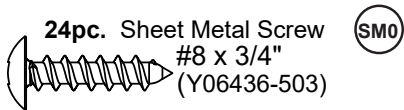
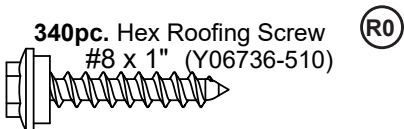
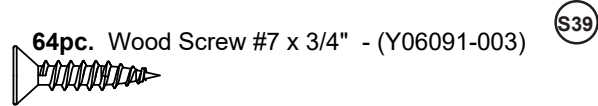
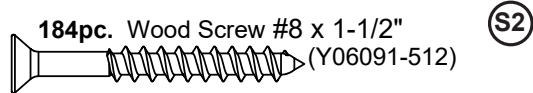
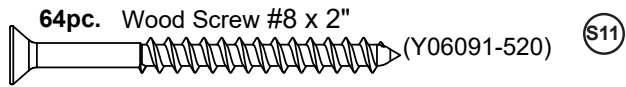
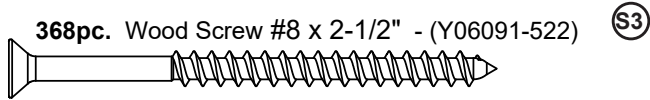
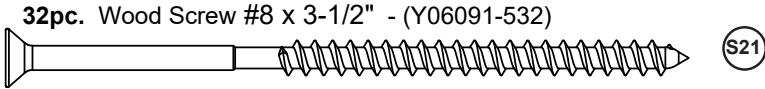
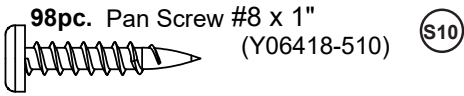
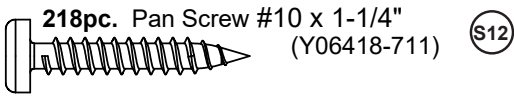

1pc. - 1/8" Drill Bit (Y00400-002)

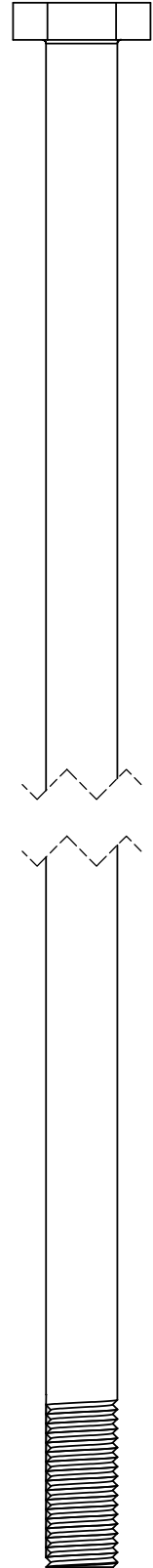

24pc. Hex Bolt 3/8 x 9-3/4" (Y07718-893)



Hardware Identification (Dimensions are approximate and are shown to assist in the identification of parts for assembly. Actual dimensions may be smaller or larger.)

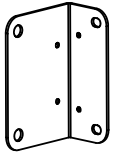

2pc. - Post Mount Set (8PK)
(Y70818-122)

4pc. Side Beam Insert - (Y00418-603)

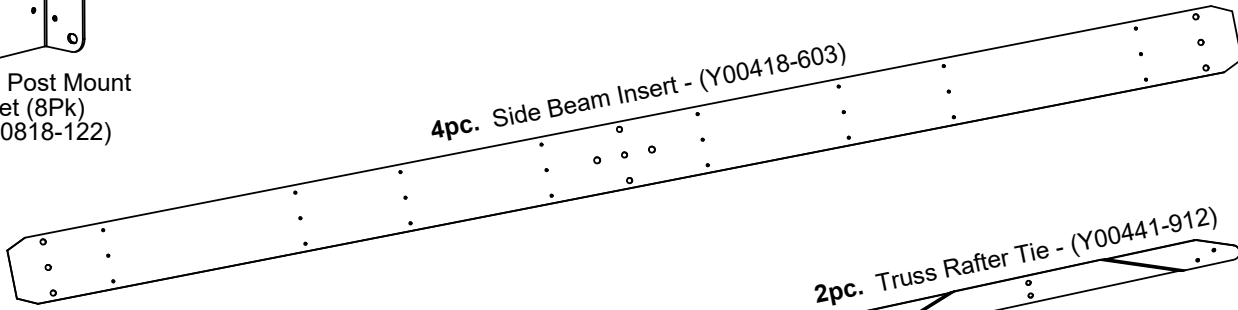

2pc. Truss Rafter Tie - (Y00441-912)

1pc. Truss Tie Vertical - (Y00441-908)

1pc. - Beam Corner Bracket Set (4PK)
(Y70818-920)

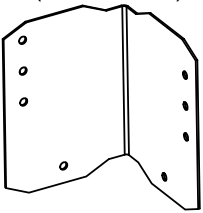

2pc. Horizontal Truss Assembly A - (Y70841-914)

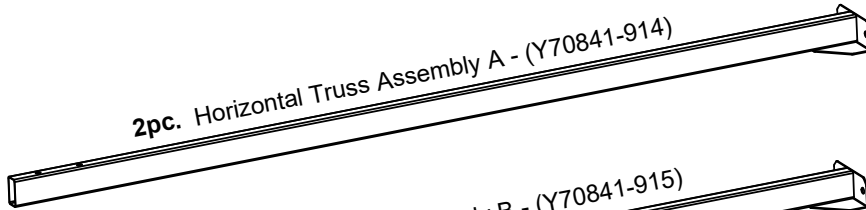

1pc. - Truss Bottom Bracket (Y00441-909)

2pc. Horizontal Truss Assembly B - (Y70841-915)

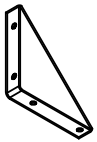
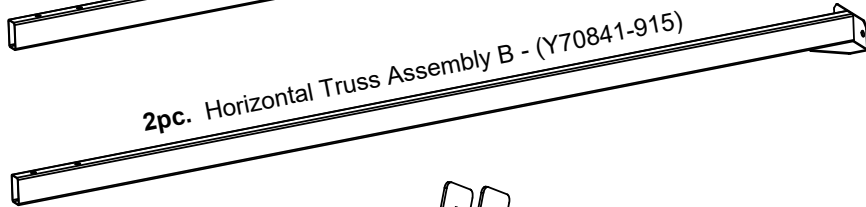

1pc. - Truss Corner Bracket Set (4PK)
(Y70841-921)

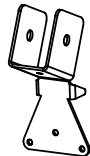

2pc. - (16PK) - (Y70818-605)
1pc. - (4PK) - (Y70818-913)
Rafter Bracket Long Set

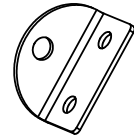

1pc. - Corner Bracket Rafter Set (8PK)
(Y70818-1201)

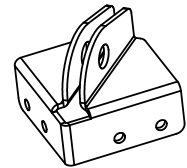

1pc. - Corner Bracket Post Set (4PK)
(Y70818-1200)

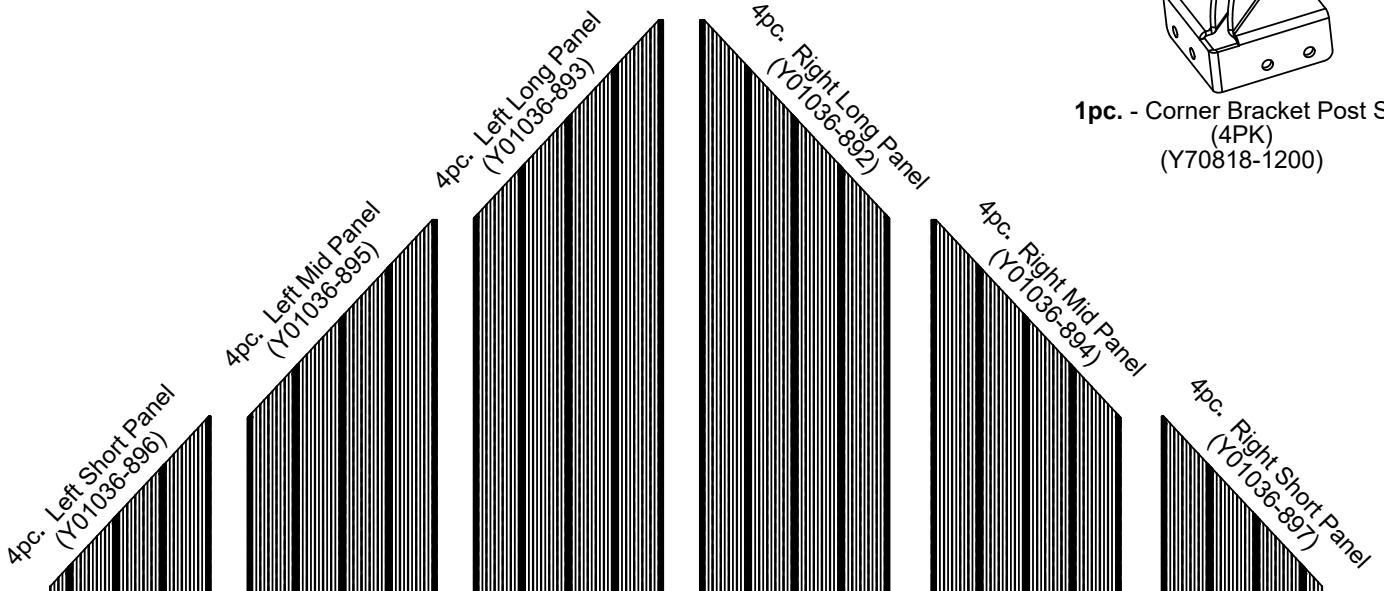

1pc. 16 x 16 Timber Frame Roof Panel Set - (Y70836-891)

Hardware Identification (Dimensions are approximate and are shown to assist in the identification of parts for assembly. Actual dimensions may be smaller or larger.)

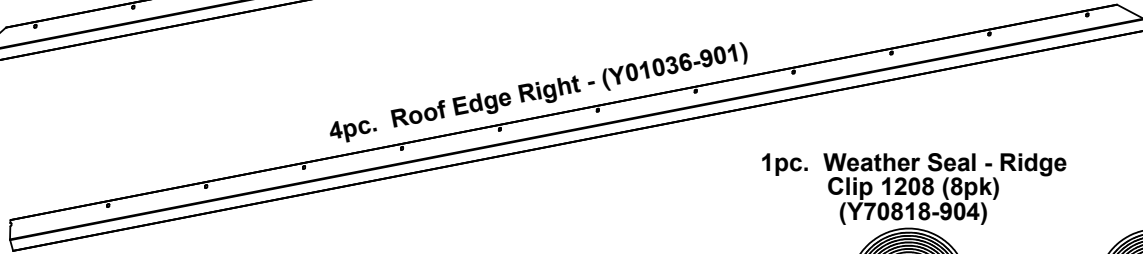
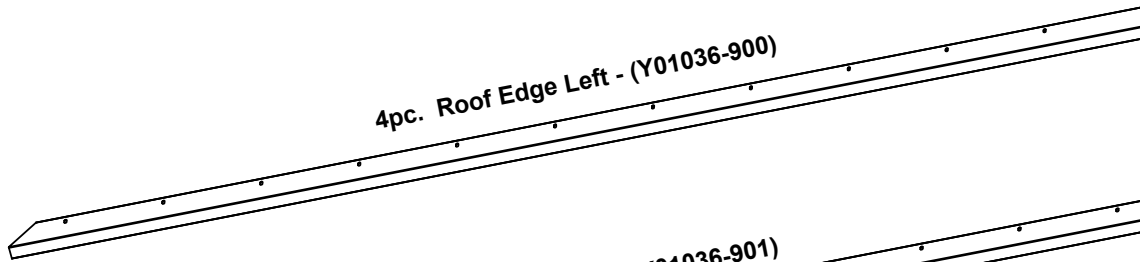

1pc. Weather Seal - Ridge Clip 1208 (8pk) (Y70818-904)

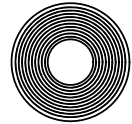
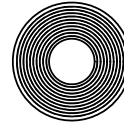

1pc. Weather Seal - Ridge Clip 2275 (8pk) (Y70818-922)

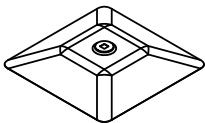
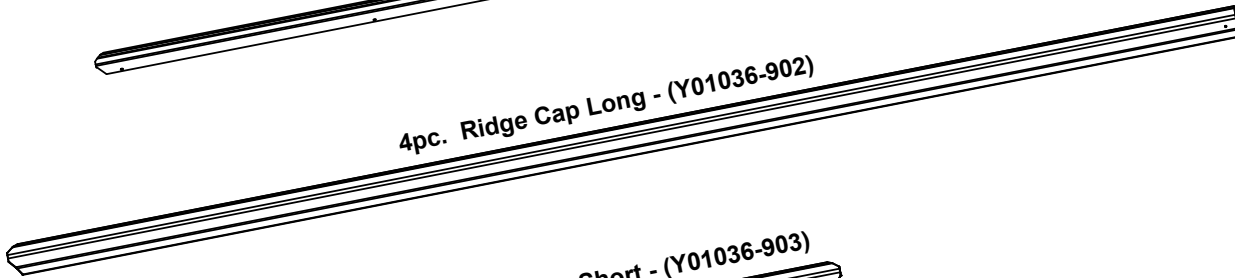
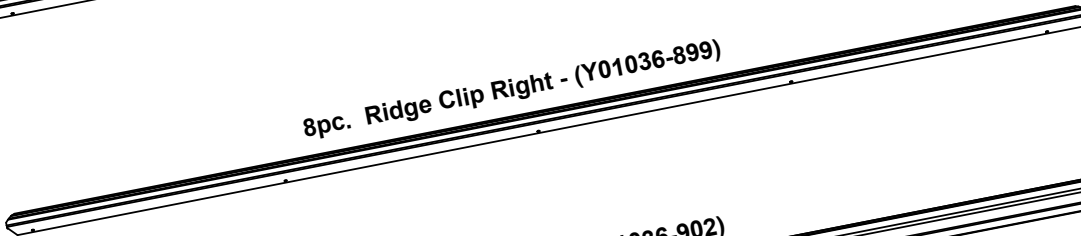
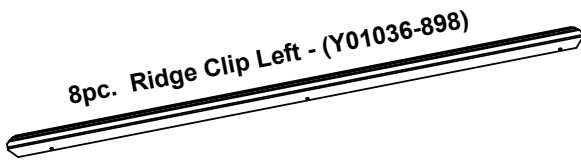

1pc. - Peak Cap (Y01036-095)



1pc. Peak Post (Y01000-1328)

1pc. - Roof Peak Set (Y70836-1462)

1pc. Contoured Washer (Y05918-211)

1pc. Carriage Bolt (Y07490-271)

1pc. Spring Clip (Y09490-001)

2pc. Roof Peak Bracket (Y00418-919)

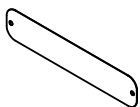

1pc. - Gazebo ID Plaque (Y70800-104)



1pc. - Corner Cap (4Pk) (Y70836-226)

Step 1: Inventory Parts - Read This Before Starting Assembly

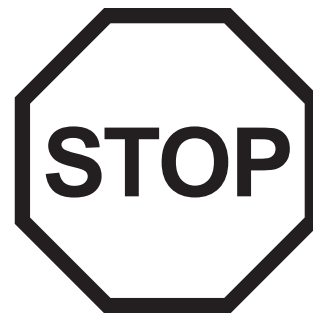
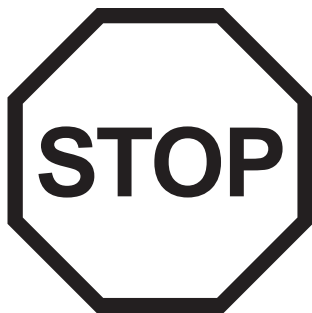
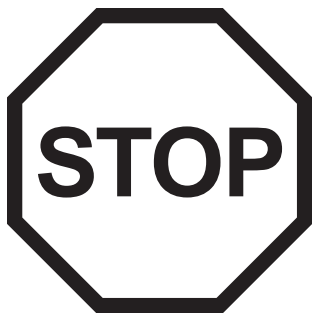

- A. This is the time for you to inventory all your hardware, wood and accessories, referencing the parts identification sheets. This will assist you with your assembly.
- Each step indicates which bolts and/or screws you will need for assembly, as well as any flat washers, lock washers, t-nuts or lock nuts.
- B. If there are any missing or damaged pieces or you need assistance with assembly please contact the consumer relations department directly. Call us before going back to the store.

1-888-509-4382

support@yardistrystructures.com

- C. Read the assembly manual completely, paying special attention to ANSI warnings; notes; and safety/maintenance information on pages 1 - 4.
- Follow the instructions in order.
 - This structure is designed to be assembled and installed ideally by four people, DO NOT attempt to install alone.
 - Consider the slope of elevation where you plan to install the structure. Also, check for gas, telephone, other utilities or sprinkler line locations prior to excavating any holes.
- D. Before you discard your cartons fill out the form below.
- The carton I.D. stamp is located on the end of each carton.
 - Please retain this information for future reference. You will need this information if you contact the Consumer Relations Department.

PRODUCT NUMBER: **YM12875X**

CARTON I.D. STAMP: __ __ __ __ __ 14459 __ (Box 1)

Step 2: Post Assemblies

A: At the bottom of (2038), insert eight TN2s on the outside of each post. (F2.1)

B: At the bottom of each Post place four Post Mounts tight to the bottom and inside faces as shown in (F2.1 and F2.2). Loosely attach with two G1 (with LW2 and FW2) per mount so they connect to the T-Nuts. From the bottom attach with two S3 and two S12 per mount. The S12's are installed on a slight angle. Tighten bolts.

C: Flush to the bottom of each Post place one (1465) on each post side and attach with four S3 per plinth. Rounded edges on top. (F2.2 and F2.3)

D: Repeat for three additional Post Assemblies.

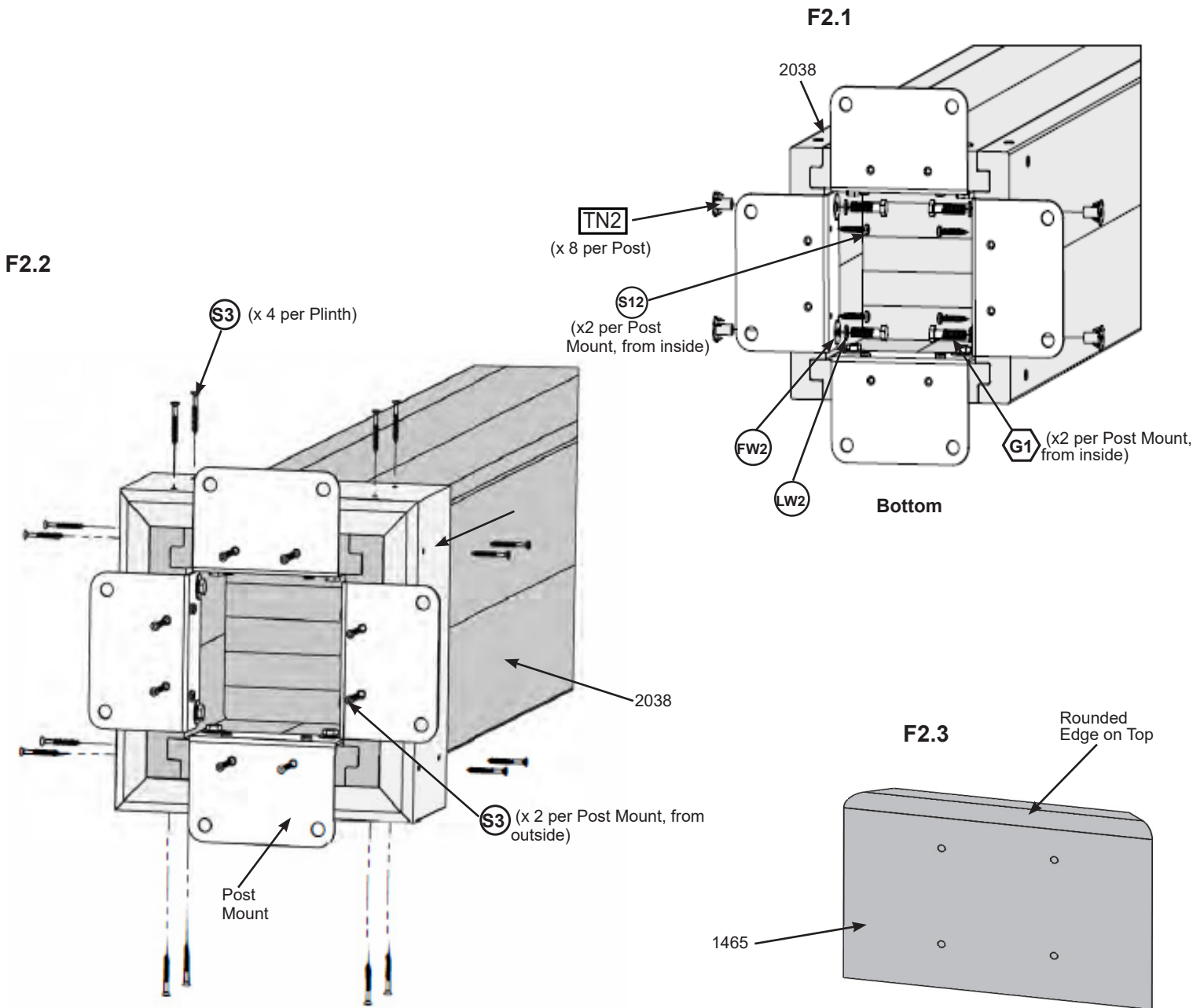

Wood Parts

4 x (2038) 9 x 9 Post
16 x (1465) Plinth

Components

16 x Post Mount

Hardware

96 x S3 #8 x 2-1/2" Wood Screw

32 x S12 #10 x 1-1/4" Pan Screw

32 x TN2 5/16" T-Nut

32 x G1 5/16 x 1-1/2" Hex Bolt

32 x LW2 5/16" Lock Washer

32x FW2 5/16" Flat Washer

Step 3: Long Beam Assemblies

Part 1

A: Connect one (1462) to each end of one (1461) using two G2 (with LW2, FW12 and TN2) per end as shown in F3.1 and F3.2.

B: Connect one (1459) and one (1460) using two G2 (with LW2, FW12 and TN2) as shown in F3.1 and F3.2.

Align bolt holes in all pieces with G2

F3.1

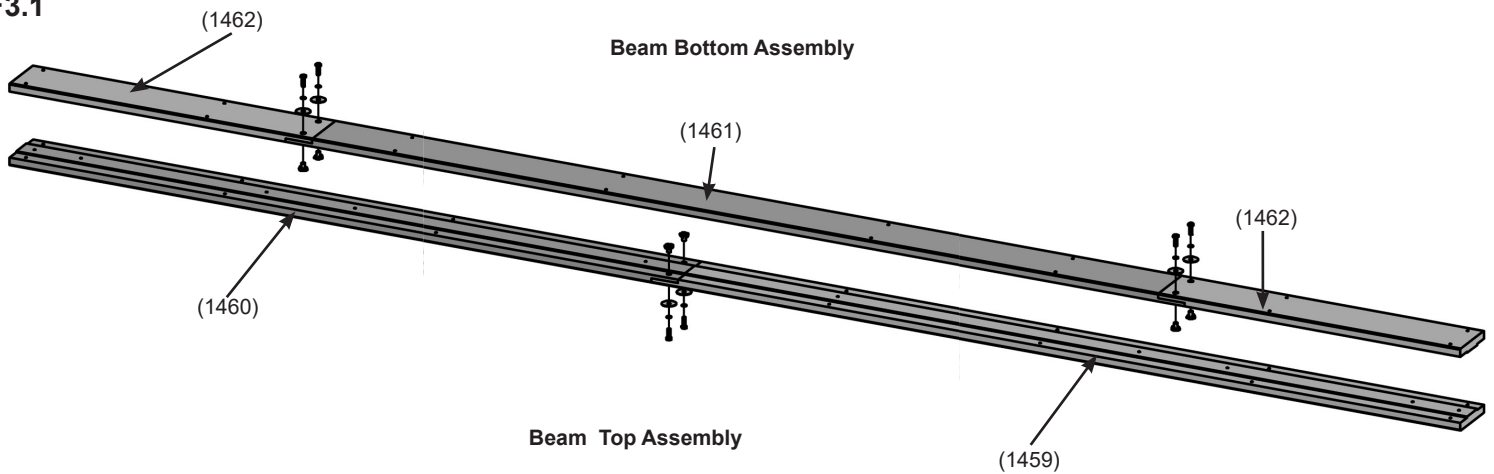



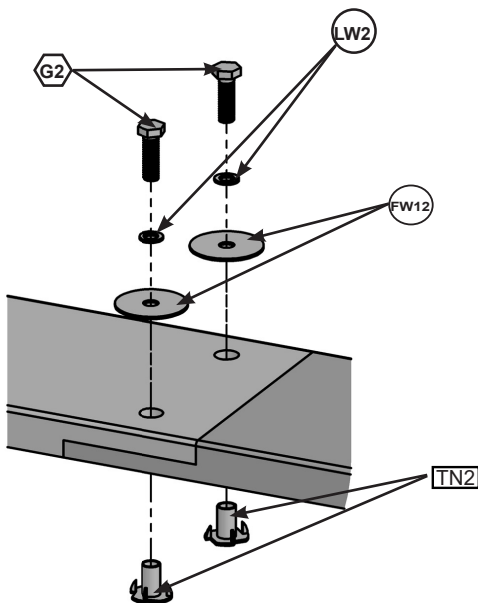

F3.2



Wood Parts

- 4 x (1462) Beam Bottom End
- 2 x (1459) Beam Top RT
- 2 x (1460) Beam Top LT
- 2 x (1461) Beam Bottom Centre

Hardware

- 12 x  5/16" x 1" Hex Bolts
- 12 x  1/4-5/16" Large Washer
- 12 x  5/16" T-Nut
- 12 x  5/16" Lock Washer

Step 3: Long Beam Assembly Part 2

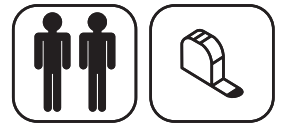

C: Install three TN2 by tapping into the long face of two (2049). Install two TN2 by tapping into the short face of (1495). Place the two (2049) with T-Nuts facing down at each end of (1495) with T-Nuts facing down. (F3.3 and F3.4)

D: Place two (2048) one at each end of the (2049) and two (1472) at a distance of 16-3/4" apart from each (2048). (F3.5 and F3.6)

E: Place one (1473) at the centre of the (1495). It should measure 27-1/2" to the end of each (1472). This will verify central position. (F3.5 and F3.6)

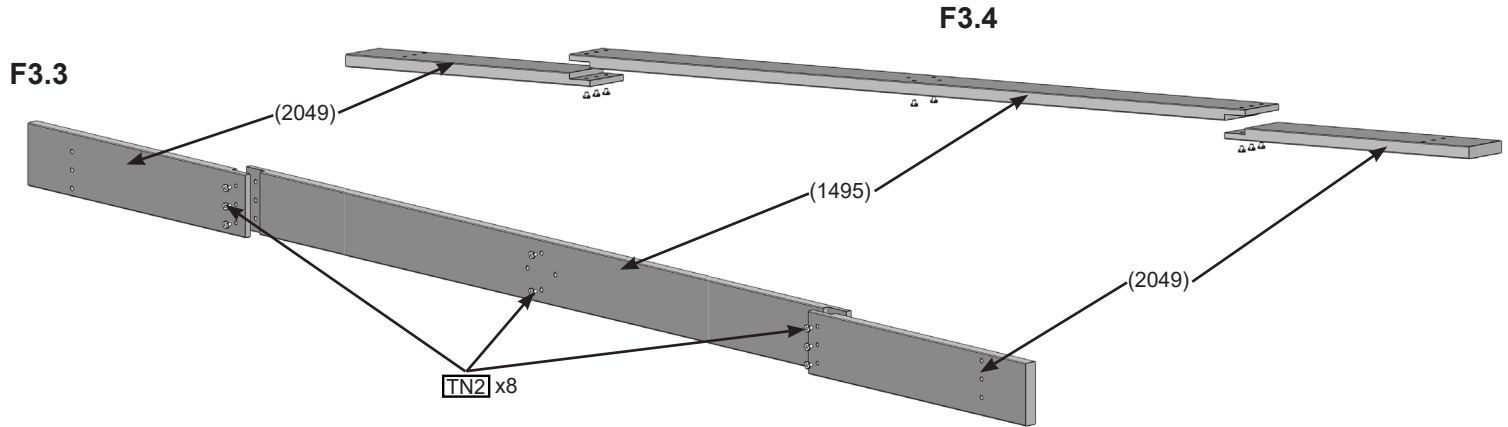

F3.5

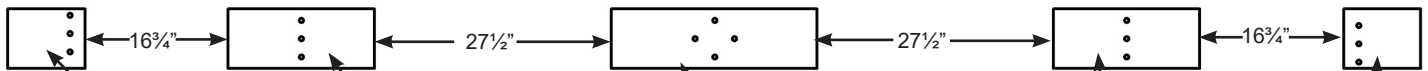

F3.6

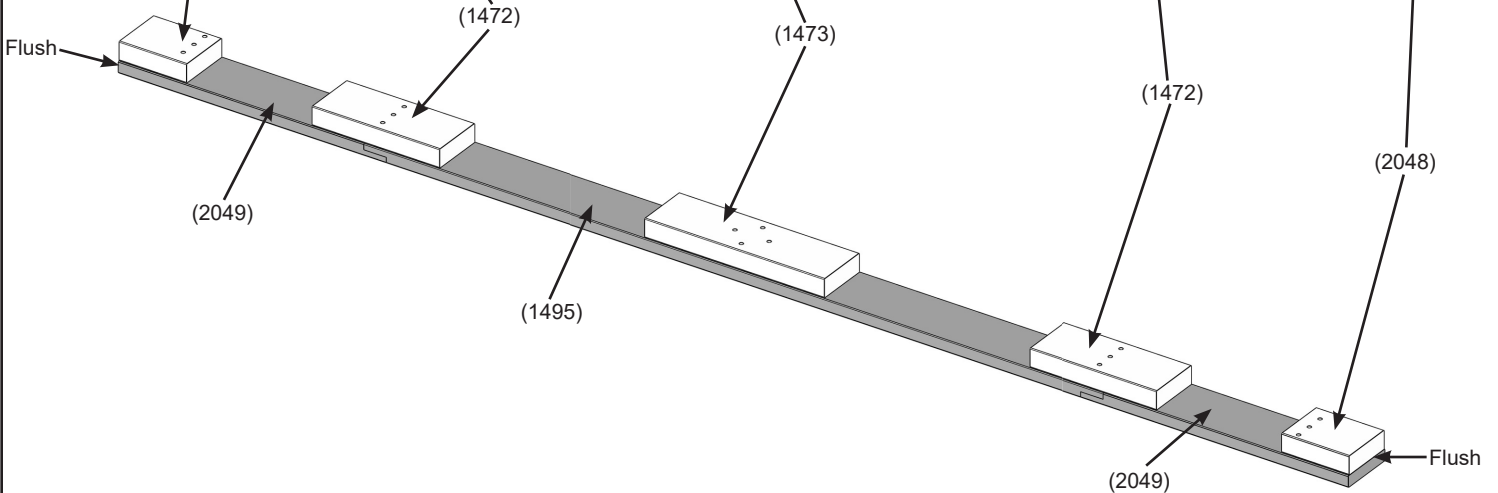

Wood Parts

- 4 x (2048) Beam Block 9"
- 4 x (1472) Beam Block 17"
- 2 x (1473) Beam Block 24"
- 2 x (1495) Beam Back Centre
- 4 x (2049) HBL Back End

Hardware

- 16 x **TN2** 5/16" T-Nut

Step 3: Long Beam Assembly Part 3

F: Place one (2041) and one (2042) on top of the Beam Blocks from previous step. Align holes of the (2041) and (2042) to the holes on the outside faces of the Beam Blocks. Match the bolt holes in both beam assemblies and all Beam Blocks. (F3.7)

G: Place one Side Beam Insert on (2041) and (2042) and align holes using six G23 through the bolt holes at each end and two G23 at the centre. (F3.8, F3.9 and F3.10)

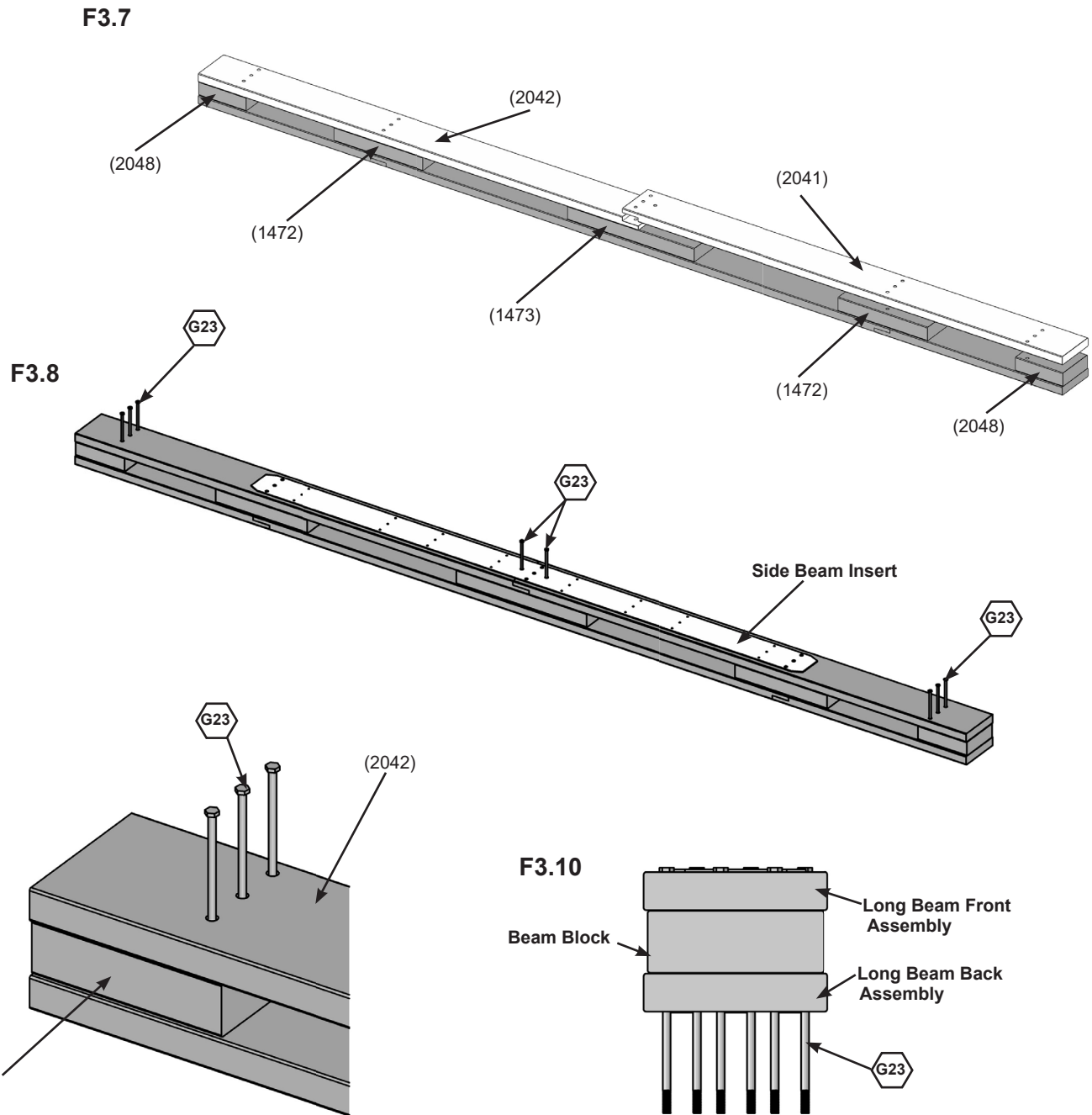

Wood Parts

2 x (2041) HBL Front LT
2 x (2042) HBL Front RT

Components

2 x Side Beam Insert

Hardware

8 x  3/8 x 9-3/4" Hex Bolt
(For placement purposes only)

Step 3: Long Beam Assembly Part 4

H: Connect Beam Assemblies, Beam Blocks and Beam Insert together with eight G35 (with LW2 and FW2). *The 5/16" t-nut has been previously installed in Part 2 of this Step.* (F3.11, F3.12 and F3.13). **Keep bolts loose.**

F3.11

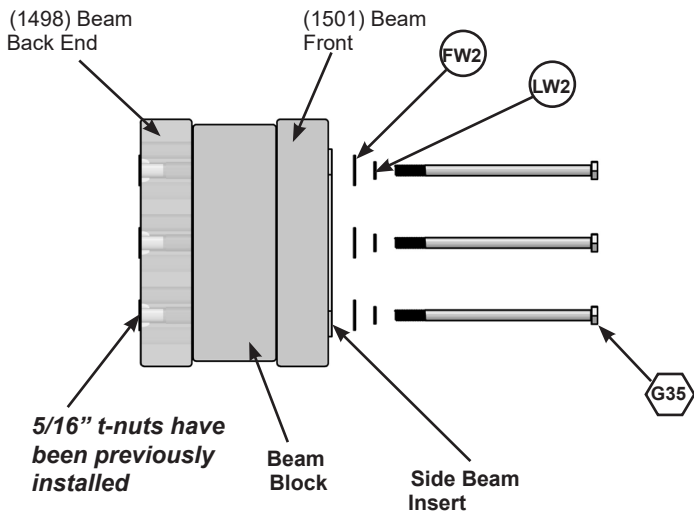

F3.12

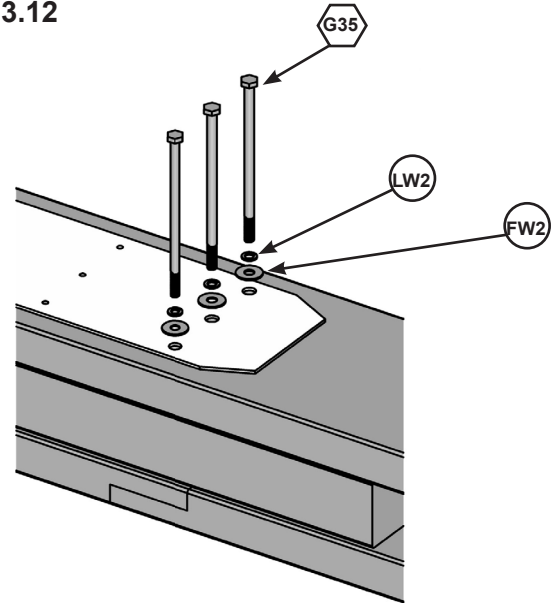

F3.13

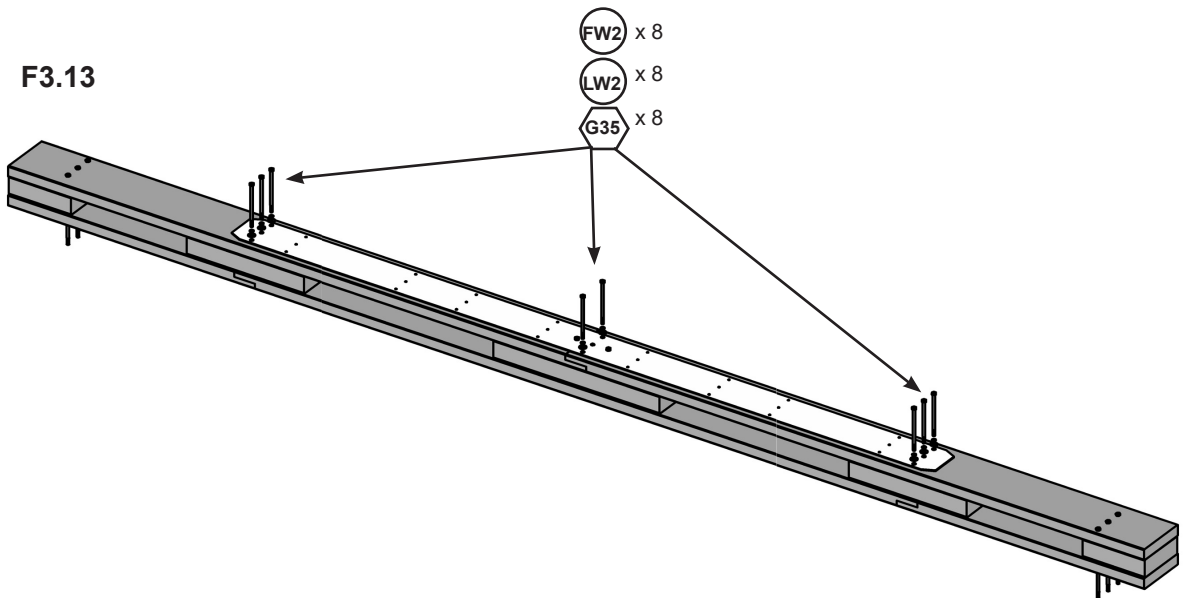

Hardware

16 x  5/16 x 5-3/4" Hex Bolt

16 x  5/16" Lock Washer

16 x  5/16" Flat Washer

Step 3: Long Beam Assembly Part 5



I: With a helper and the 3/8" Bolts still in place, flip the assembly up and place the Beam Top assembly from Part 1 so the groove sits tight and flush with the beam assembly then fasten with (26) S3. (F3.14 and F3.15)

F3.14

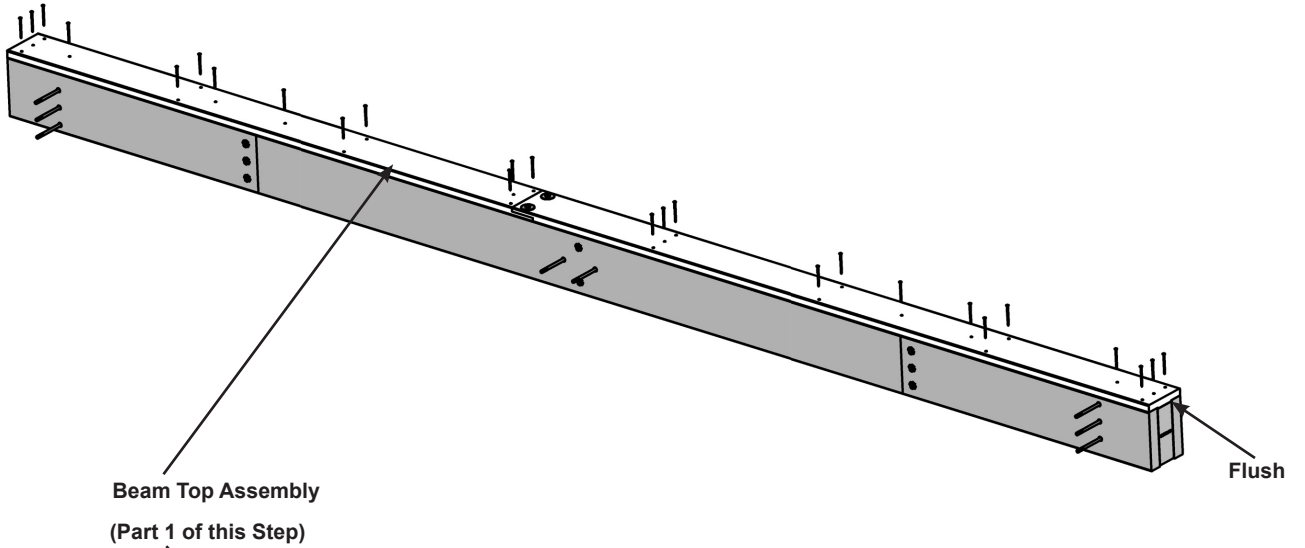

F3.15

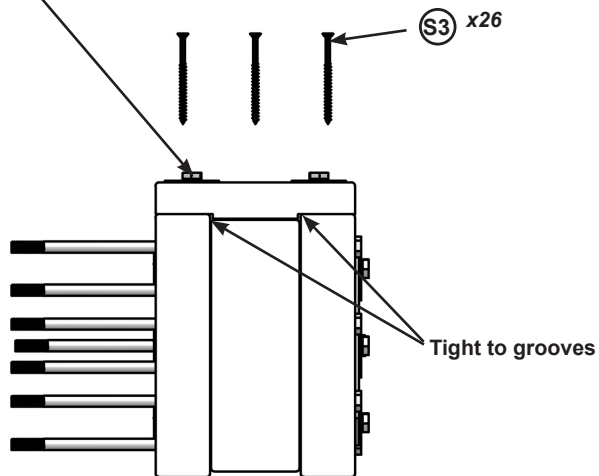

Hardware

52 x S3 #8 x 2-1/2" Wood Screw

Step 3: Long Beam Assembly Part 6

J: Flip the assembly over and place Beam Bottom Assembly from Part 1 so the groove sits tight and flush to the beam assemblies and fasten with (16) S3 (F3.16 and F3.17)

Remove the G23 bolts from each end of this assembly.

K: Fasten Side Beam Insert to the beam with (24) S10. (F3.16 and F3.17)

Before continuing onto the next step, tighten all bolts

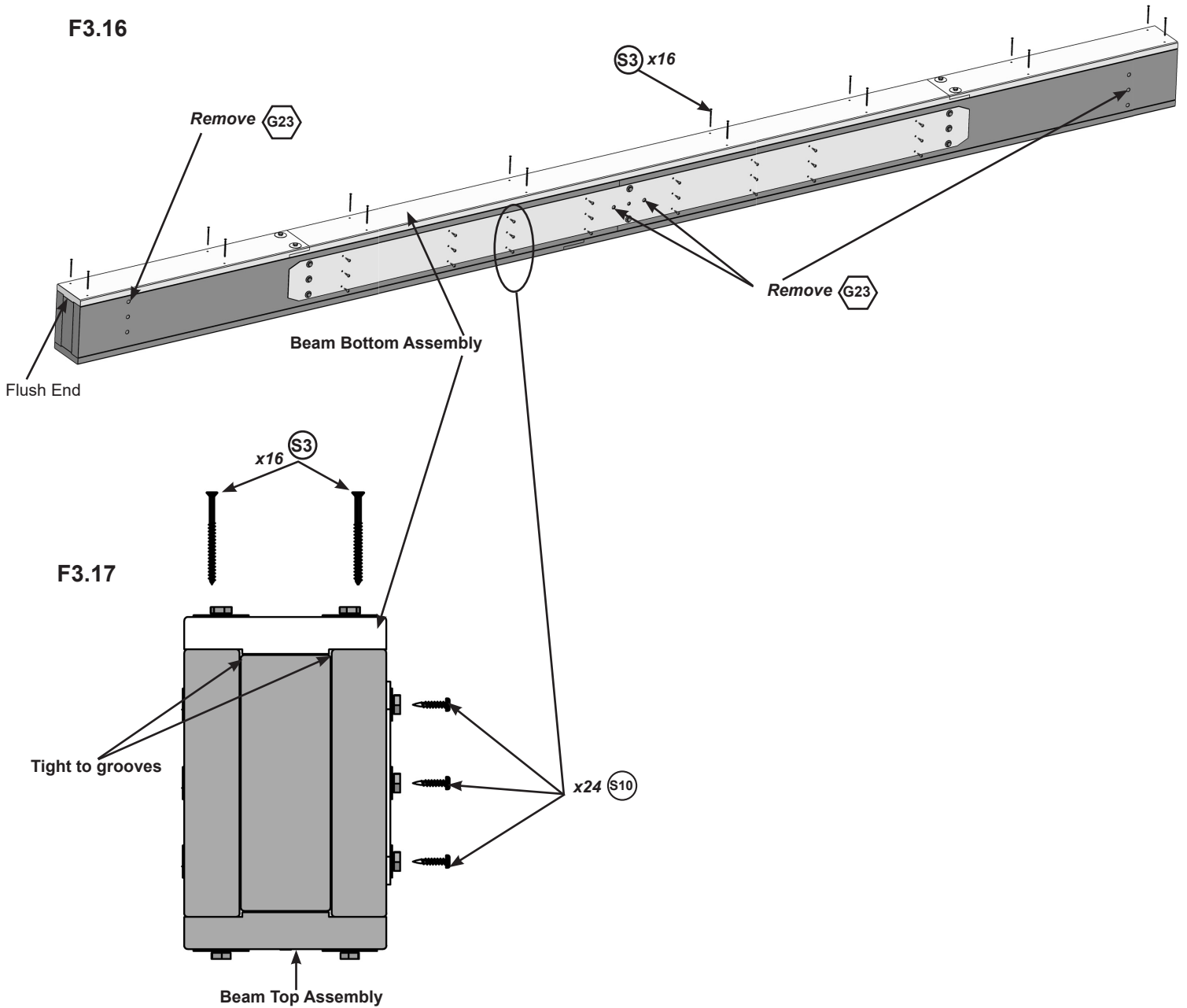

Hardware

48 x S10 #8 x 1" Pan Screw

32 x S3 #8 x 2-1/2" Wood Screw

Step 3: Long Beam Assembly Part 7

L: Fasten Side Beam Insert to Side Beam Assembly with one LS6 (with FW2) .
(F3.18, F3.19 and F3.20)

M: Repeat Steps A-L for a second Side Beam Assembly.

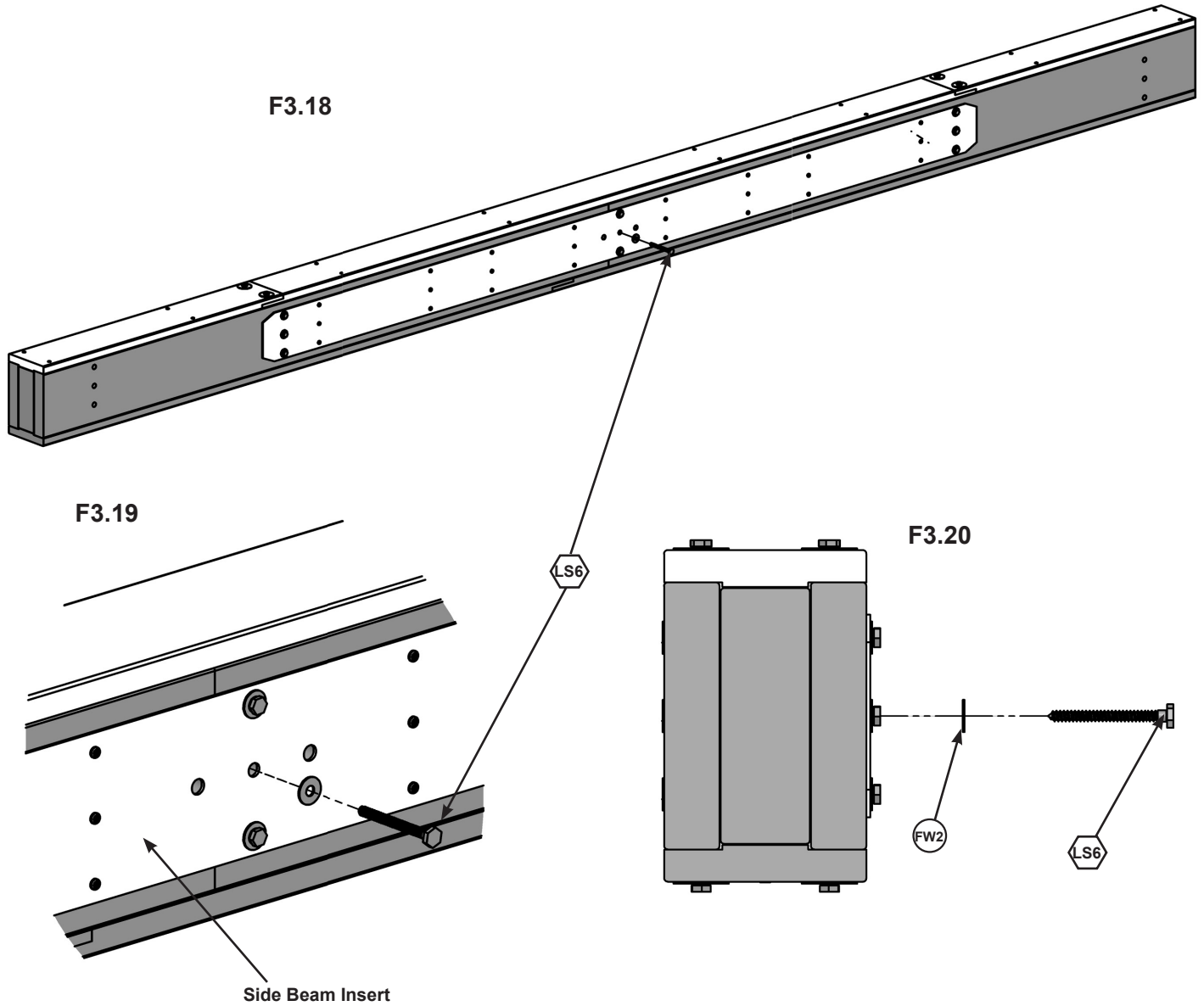

Hardware

2 x  5/16" x 3" Lag Screw

2 x  5/16" Flat Washer

Step 4: Short Beam Assemblies Part 1

A: Connect one (2047) to each end of one (1461) using two G2 (with LW2, FW12, and TN2) per end as shown in F4.1 and F4.2.

B: Connect one (2045) and one (2044) using two G2 (with LW2, FW12 and TN2) as shown in F4.1 and F4.2.

Align bolt holes in all pieces with 

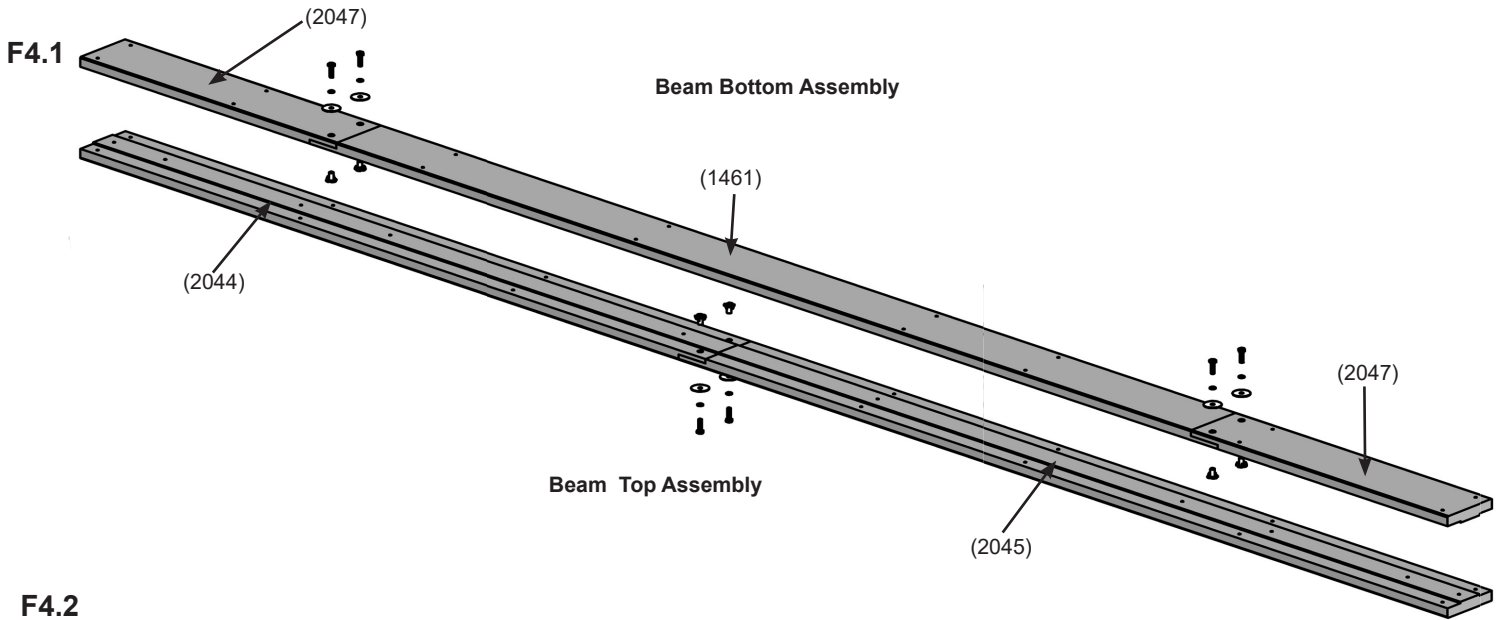

F4.2

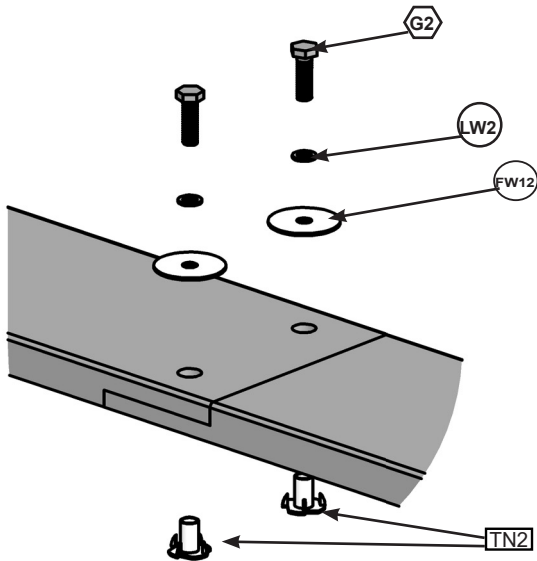

Wood Parts

- 2 x (1461) Beam Bottom Centre
- 2 x (2044) HB Top LT
- 2 x (2045) HB Top RT
- 4 x (2047) HB Bottom End

Hardware

- 12 x  5/16" x 1" Hex Bolt
- 12 x  1/4-5/16" Large Washer
- 12 x  5/16" T-Nut
- 12 x  5/16" Lock Washer

Step 4: Short Beam Assembly Part 2

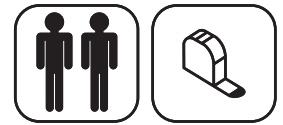

C: Install three TN2 by tapping into the long face of two (2043). Install two TN2 by tapping into the short face of (1495). Place the two (2043) with T-Nuts facing down at each end of (1495) with T-Nuts facing down. (F4.3 and F4.4)

D: Place two (2048) one at each end of the (1495) and two (1472) at a distance of 11-1/4" apart from each (2048). (F4.5 and F4.6)

E: Place one (1473) at the centre of the (1495). It should measure 27-1/2" to the end of each (1472). This will verify central position. (F4.5 and F4.6)

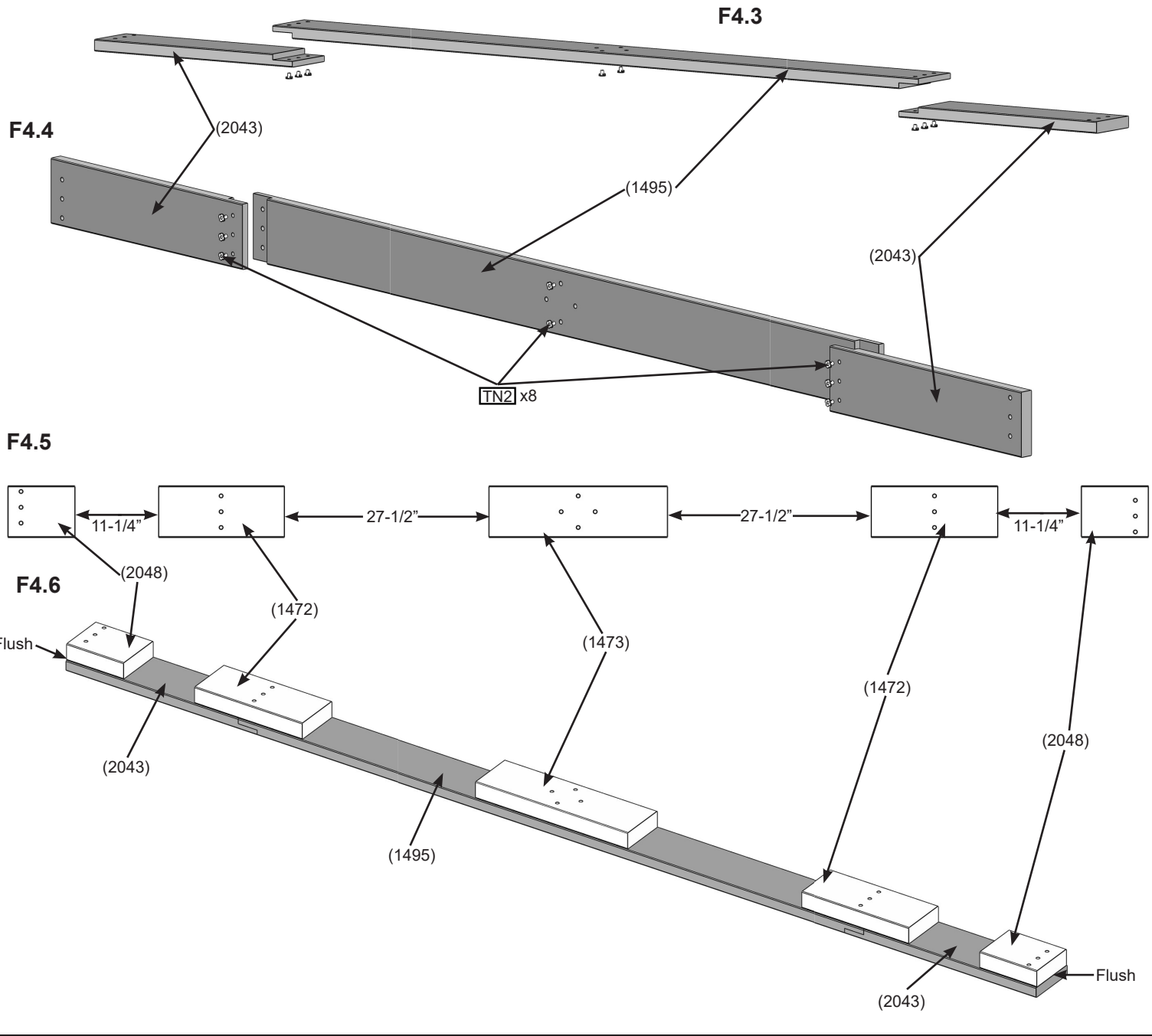

Wood Parts

- 4 x (2048) Beam Block 9"
- 4 x (1472) Beam Block 17"
- 2 x (1473) Beam Block 24"
- 2 x (1495) Beam Back Centre
- 4 x (2043) HB Back End

Hardware

- 16 x TN2 5/16" T-Nut

Step 4: Short Beam Assembly Part 3

F: Place one (2040) and one (2039) on top of the Beam Blocks from previous step. Align holes of the (2040) and (2039) to the holes on the outside faces of the Beam Blocks. Match the bolt holes in both beam assemblies and all Beam Blocks. (F4.7)

G: Place one Side Beam Insert on (2040) and (2039), align holes using six G23 through the bolt holes at each end and two G23 at the centre. (F4.8, F4.9 and F4.10)

F4.7

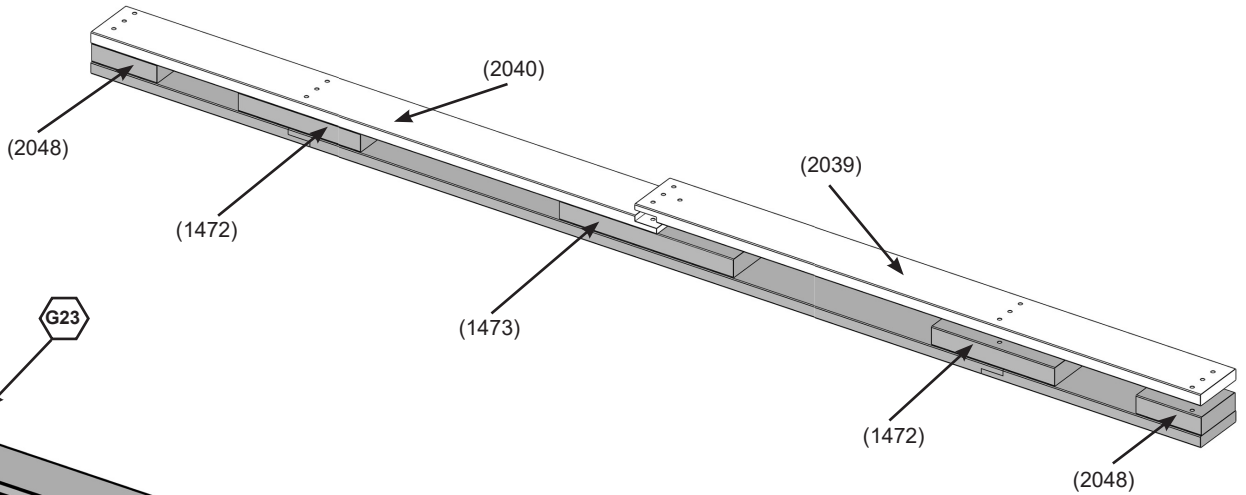

F4.8

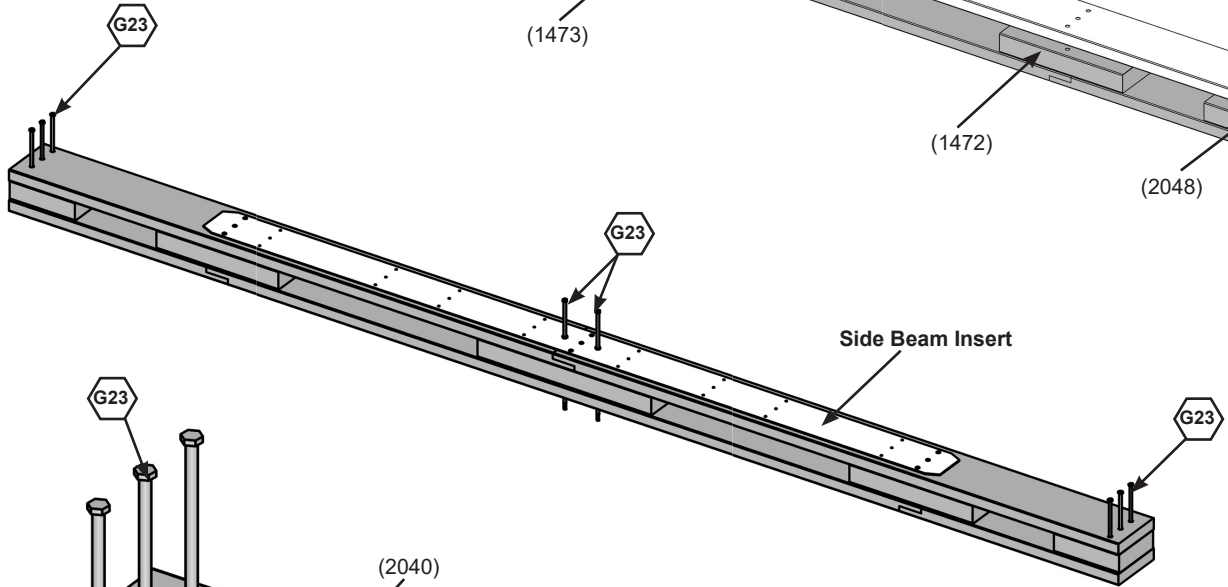

F4.9

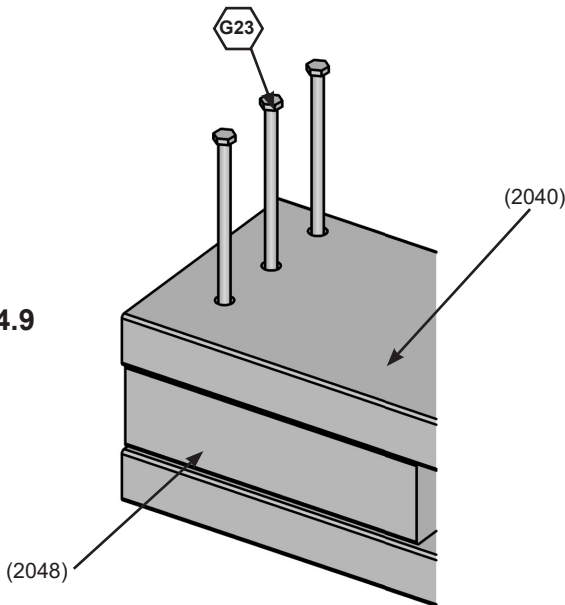

F4.10

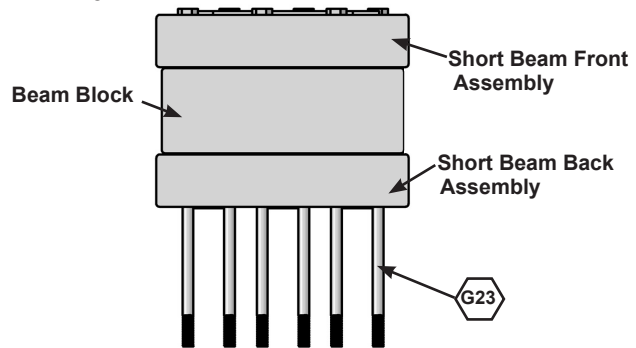

Wood Parts

- 2 x (2039) HB Front LT
- 2 x (2040) HB Front RT

Components

- 2 x Side Beam Insert

Hardware

- 8 x  3/8 x 9-3/4" Hex Bolt
(For placement purposes only)

Step 4: Short Beam Assembly Part 4

H: Connect Beam Assemblies, Beam Blocks and Beam Insert together with eight G35 (with LW2, and FW2). **The 5/16" t-nut has been previously installed in Part 2 of this Step.** (F4.11, F4.12 and F4.13). **Keep bolts loose.**

F4.11

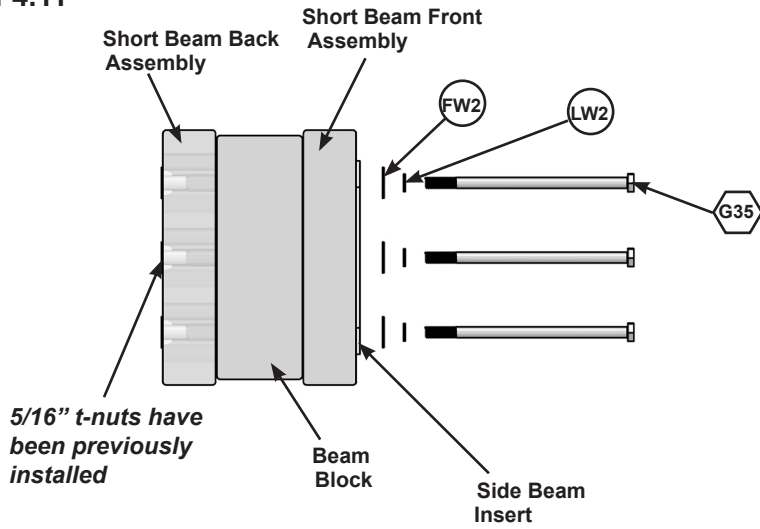

F4.12

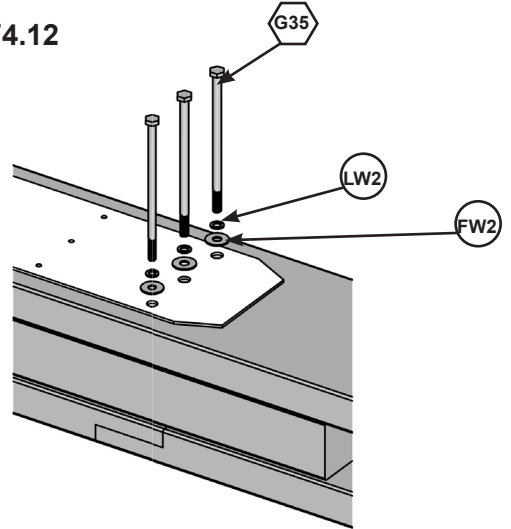

F4.13

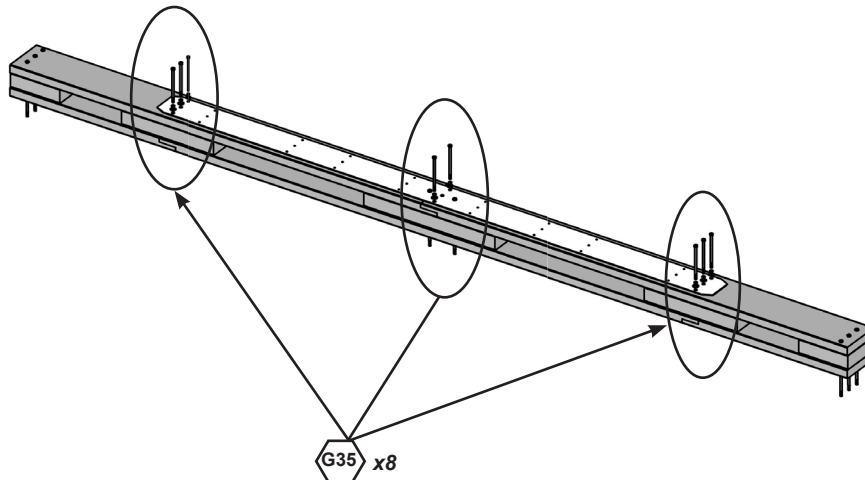

Hardware

16 x  5/16 x 5-3/4" Hex Bolt

16 x  5/16" Lock Washer

16 x  5/16" Flat Washer

Step 4: Short Beam Assembly Part 5



I: With a helper and the 3/8" Bolts still in place, flip the assembly up and place the Beam Top assembly from Part 1 so the groove sits tight and flush with the beam assembly then fasten with (26) S3. (F4.14 and F4.15)

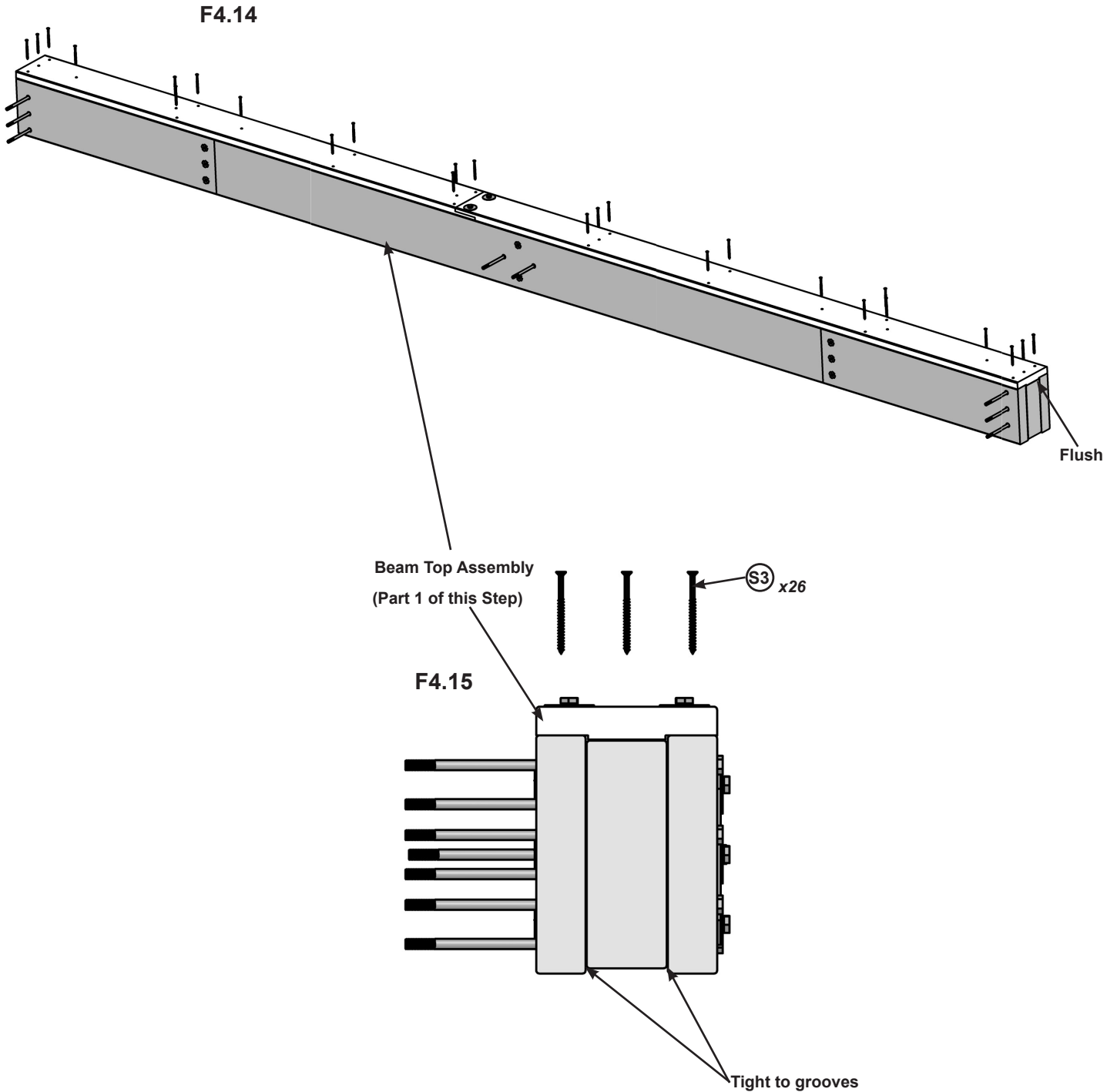

Hardware

52 x S3 #8 x 2-1/2" Wood Screw

Step 4: Short Beam Assembly Part 6

J: Flip the assembly over and place Beam Bottom Assembly from Part 1 so the groove sits tight and flush to the beam assemblies and fasten with (16) S3. (F4.16 and F4.17)

Remove G23 bolts from each end of this assembly.

K: Fasten Side Beam Insert to the beam with (24) S10. (F4.16 and F4.17)

Before continuing onto the next step, tighten all bolts

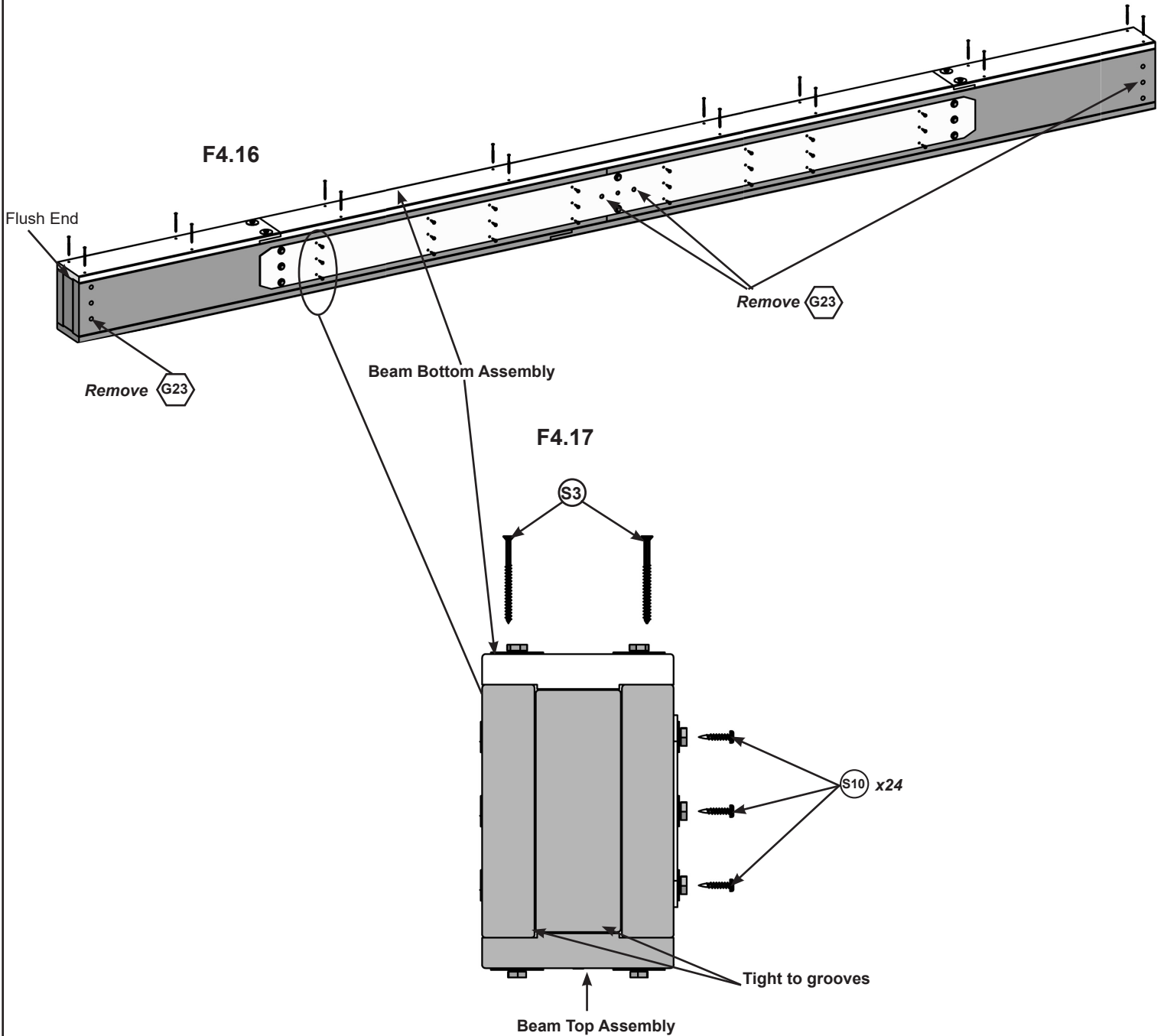

Hardware

48 x (S10) #8 x 1" Pan Screw

32 x (S3) #8 x 2-1/2" Wood Screw

Step 4: Short Beam Assembly Part 7

L: Fasten Side Beam Insert to Side Beam Assembly with one LS6 (with FW2) .
(F4.18, F4.19 and F4.20)

M: Repeat Steps A-L for a second Side Beam Assembly.

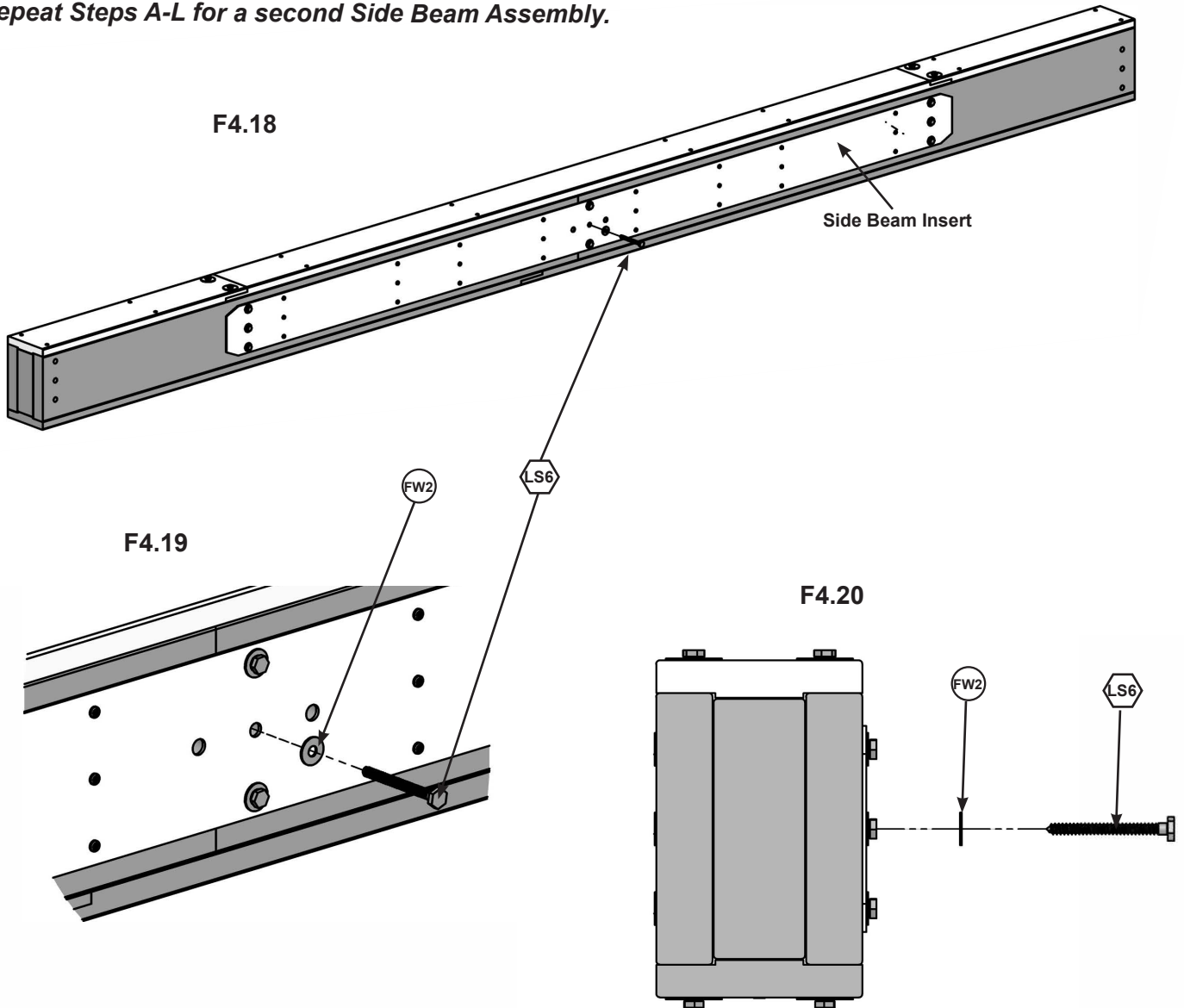

Hardware

2 x  5/16" x 3" Lag Screw

2 x  5/16" Flat Washer

Step 5: Frame Assembly and Anchoring Part 1

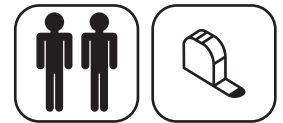

A: On a hard flat surface place one Long Beam Assembly against the outside of two Posts, flush to the tops and outside edge of post. **The beam sits in the notch out of the Post.** (F5.1 and F5.2)

B: Place Beam Corner Bracket on each end of the beam, so holes line up with the beam and post. (F5.1 and F5.3)

C: Attach with three G23 (with FW11 x 2 and LN3) per Post. The distance from the outside of one Post to the outside of the second Post should be 13' 8-1/2" (4.178m). (F5.1, F5.3 and F5.4)

D: Repeat with the other Long Beam Assembly connection to Post Assemblies.

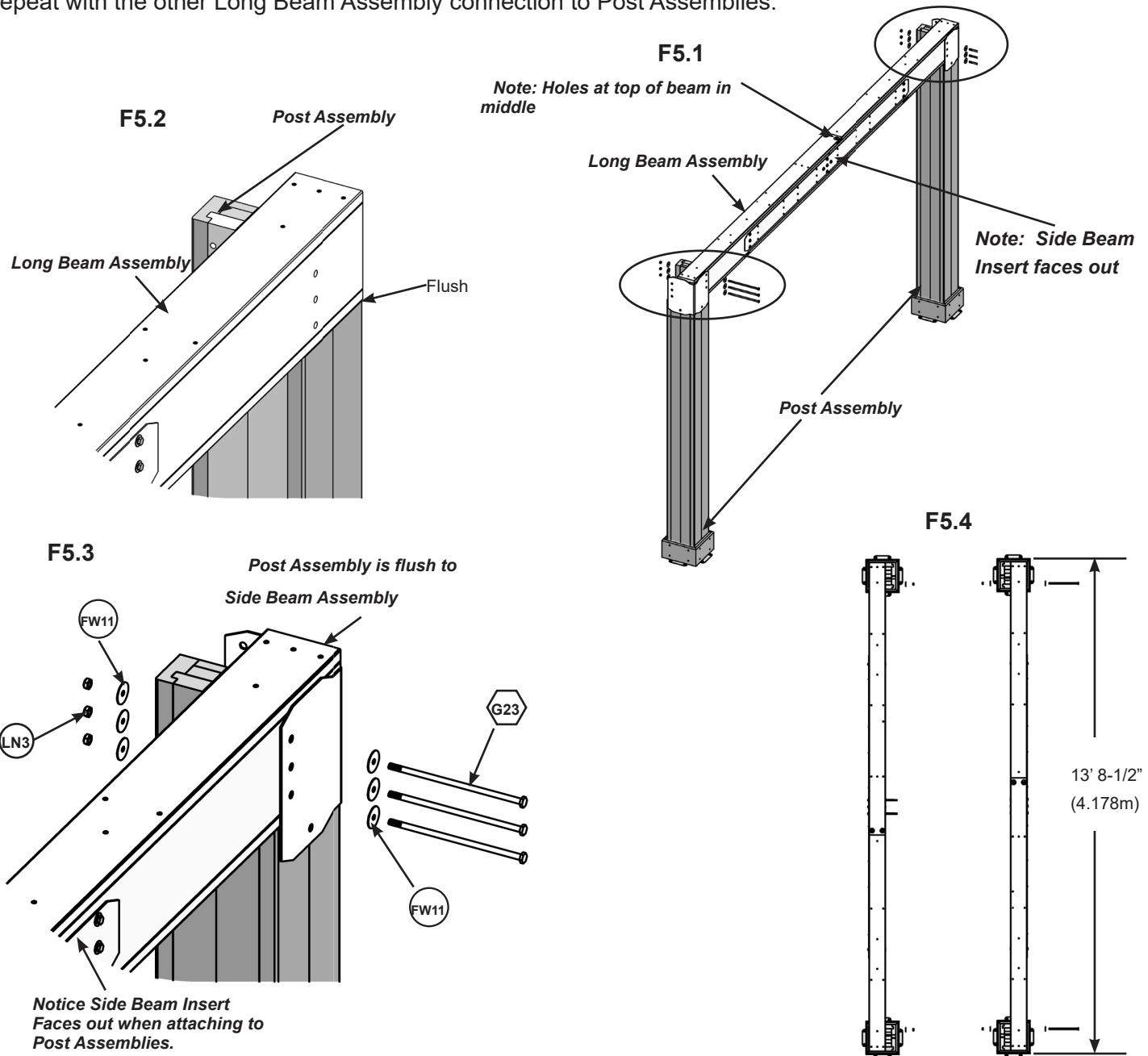

Components

4 x Beam Corner Bracket

Hardware

12 x 3/8 x 9-3/4" Hex Bolt

12 x 3/8" Lock Nut

24 x 3/8" Large Washer

Step 5: Frame Assembly and Anchoring Part 2

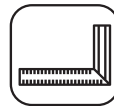

Note: Pre-drill all pilot holes using a 1/8" drill bit before installing Lag Screws.

E: Square the Beam to the Post then attach (1468) centred on Long Beam Assembly using four S21 per Gusset. (F5.5 and F5.6)

F: Attach one (1468) per Beam\Post corner joint using two LS9 (with FW2 x 2) per Gusset. (F5.5 and F5.6)

G: Fasten Beam Corner Bracket and Long Beam Assembly to each Post using one LS9 (with FW2). (F5.5 and F5.6)

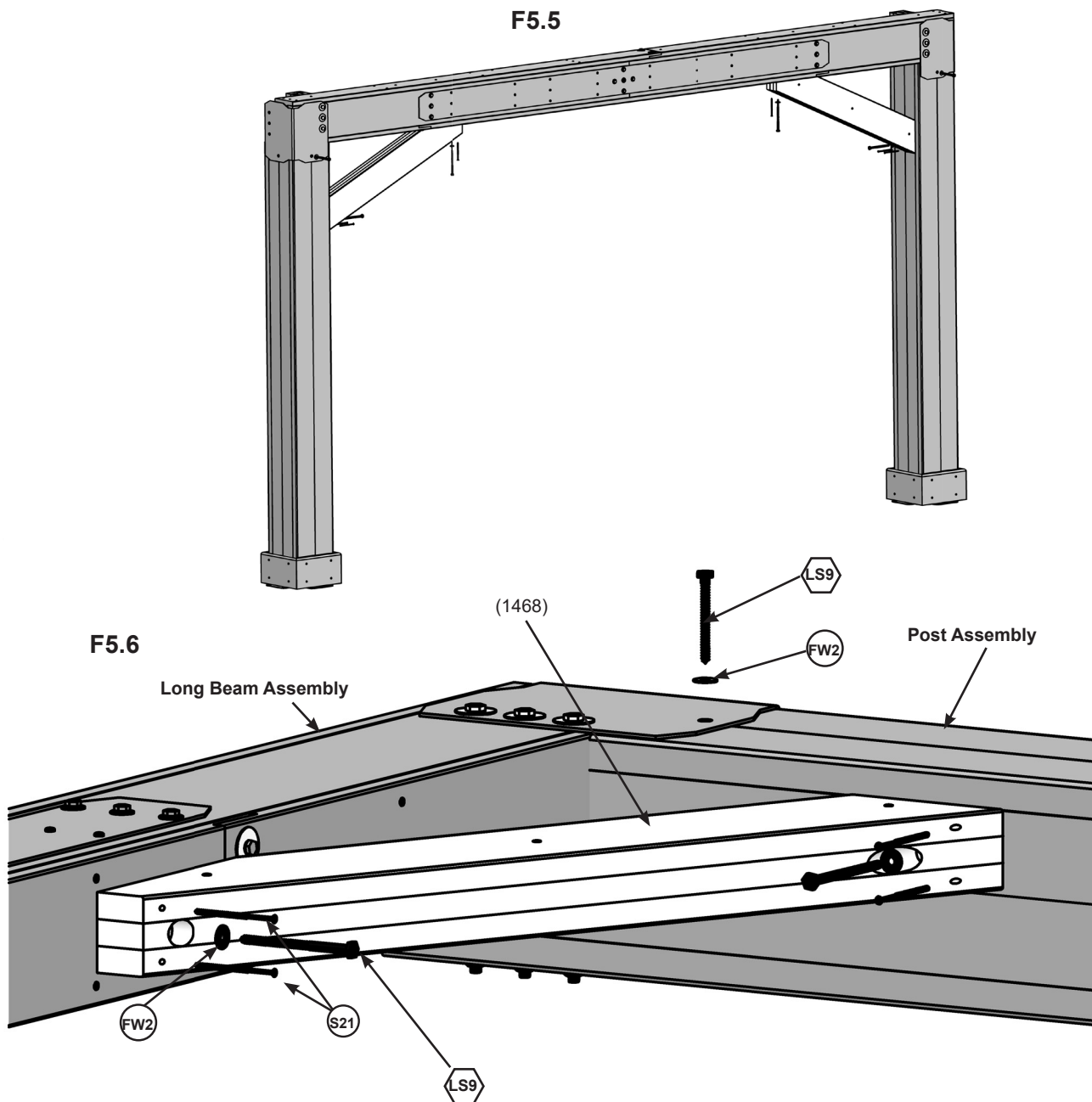

Wood Parts

4 x (1468) Gusset Side

Hardware

12 x (LS9) 5/16 x 4-3/4" Lag Screw

12 x (FW2) 5/16" Flat Washer

16 x (S21) #8 x 3-1/2" Wood Screw

Step 5: Frame Assembly and Anchoring Part 3

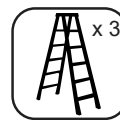

H: Move your Post/Beam Assembly to the final location. Make sure the ground is flat and level before continuing assembly.

I: With helpers stand up Post/Beam Assembly. Place one Short Beam Assembly on top of Post behind the Beam Corner Bracket with Side Beam Insert facing out and tight to Long Beam Assembly. **Note: the bolts are at the top of the Beam in the center.** Attach Beam to Post with three G23 (with FW11 x 2 and LN3) per Post. The distance from the outside of one Post to the outside of the second Post should be 13' 8-1/2" (F5.7). Continue until both Beam Assemblies are attached and the corners are tight together. (F5.7 and F5.8)

See F5.8 for accurate positioning of Posts.

J: Repeat above for other side.

F5.7

Note: Orientation of bolts

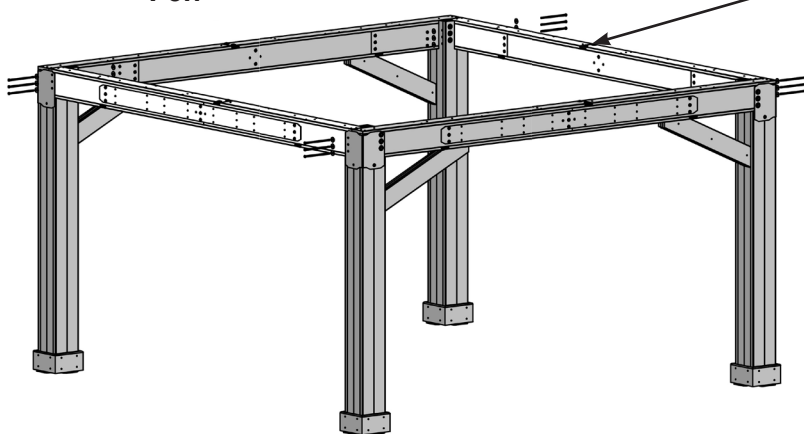

F5.8

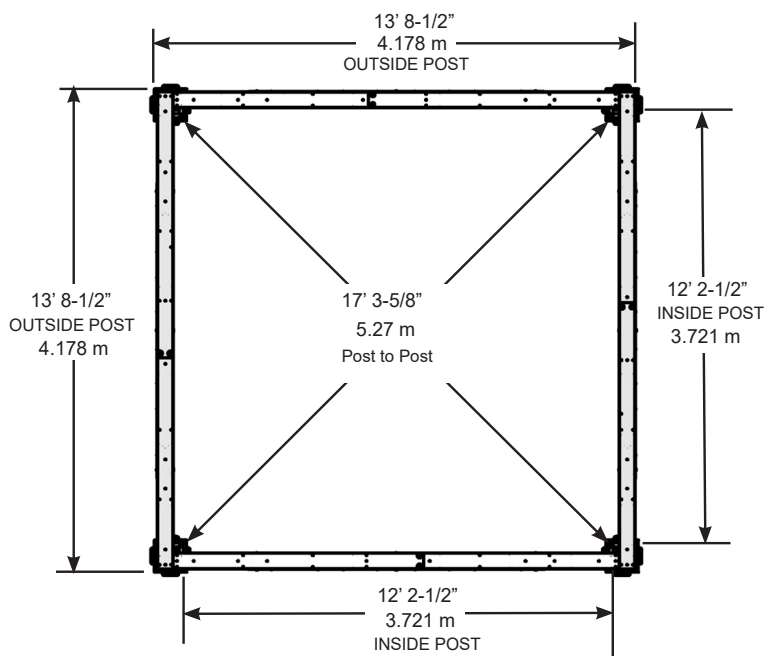

F5.9

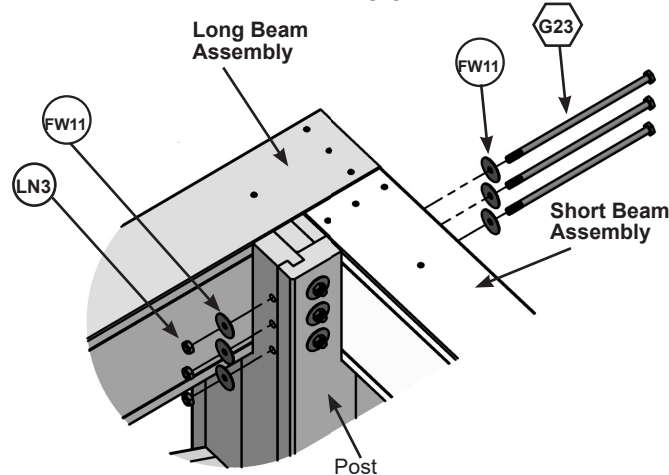

Hardware

12 x 3/8 x 9-3/4" Hex Bolt

12 x 3/8" Lock Nut

24 x 3/8" Large Washer

Step 5: Frame Assembly and Anchoring Part 4



Note: Pre-drill all pilot holes using a 1/8" drill bit before installing Lag Screws.

K: Make sure each corner is square and level then attach one (1468) Centre over Short Beam and to each Post Assembly with four S21 and two LS9 (with two FW2) as shown below. (F5.10 and F5.11) **Make sure assembly is square.**

L: Fasten Beam Corner Bracket and Short Beam Assembly to each Post using one LS9 (with FW2). (F5.10 and F5.11)

M: Depending on what you are placing the Gazebo on will determine how you anchor it to that surface. Please refer to pages 6 and 7 for installation examples.

Any hardware or extra materials for mounting will have to be purchased in advance.

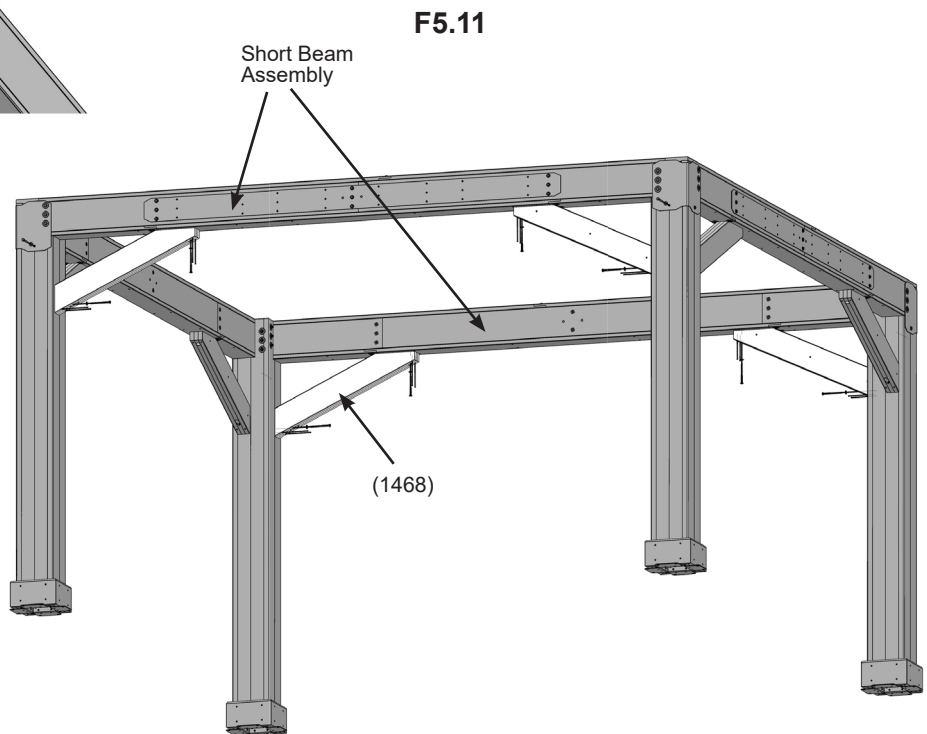
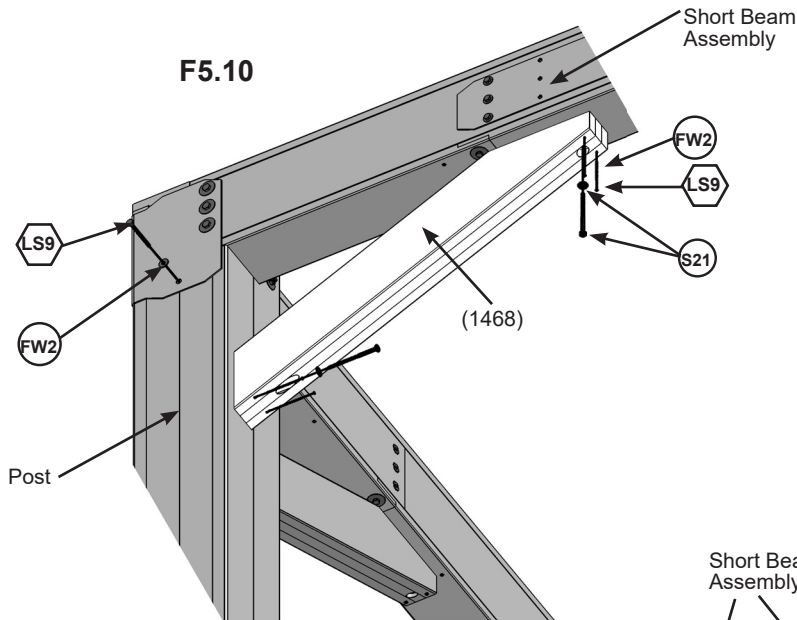

Wood Parts

4 x (1468) Gusset Side

Hardware

12 x 5/16 x 4-3/4" Lag Screw

12 x 5/16" Flat Washer

16 x #8 x 3-1/2" Wood Screw

Step 6: Roof Panel Assembly

Part 1

A: Tightly connect one (2592) to (2594), one (2591) to (2593) and one (2022) to (2023) using one G1 (with LW2, FW12 and TN2) per assembly. (F6.1, F6.2, F6.3, F6.4, F6.5, F6.6)

B: Repeat three more times for each assembly.

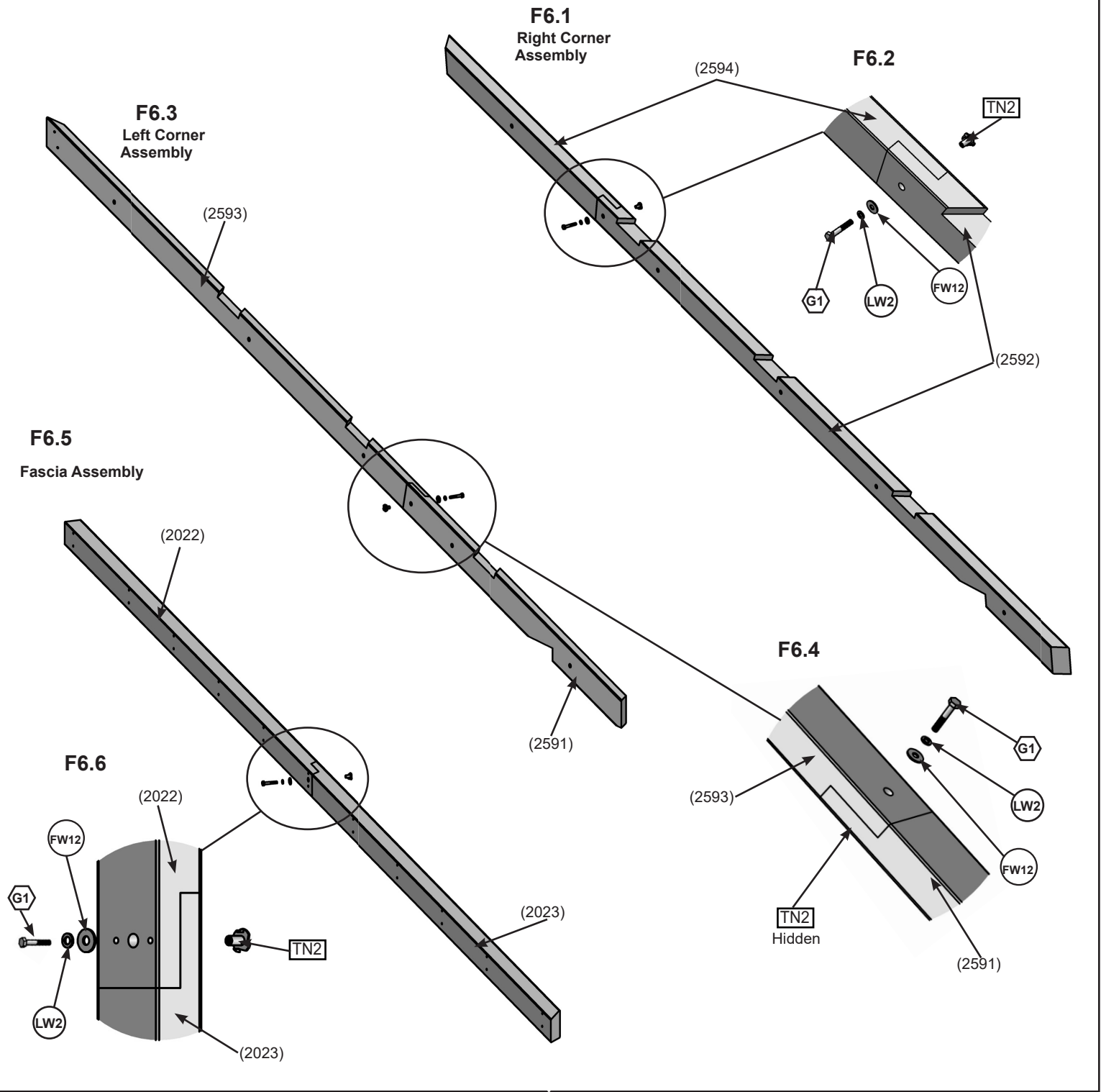

Wood Parts

- | | |
|---------------------------------|----------------------------------|
| 4 x (2022) Fascia End Left | 4 x (2592) Corner Rafter Right A |
| 4 x (2023) Fascia End Right | 4 x (2594) Corner Rafter Right B |
| 4 x (2591) Corner Rafter Left A | |
| 4 x (2593) Corner Rafter Left B | |

Hardware

- | | |
|-------------------------------------|---------------------------------------|
| 12 x TN2 5/16" T-Nut | 12 x G1 5/16 x 1-1/2" Hex Bolt |
| 12 x FW12 5/16" Large Washer | 12 x LW2 5/16" Lock Washer |

Step 6: Roof Panel Assembly

Part 2

C: Lay out the Left Corner and Right Corner Rafter Assemblies and attach to (2581) using two S3 per side (F6.7, F6.8, F6.9)

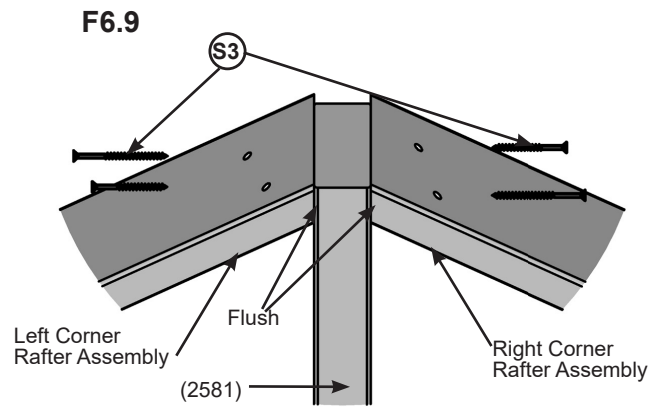
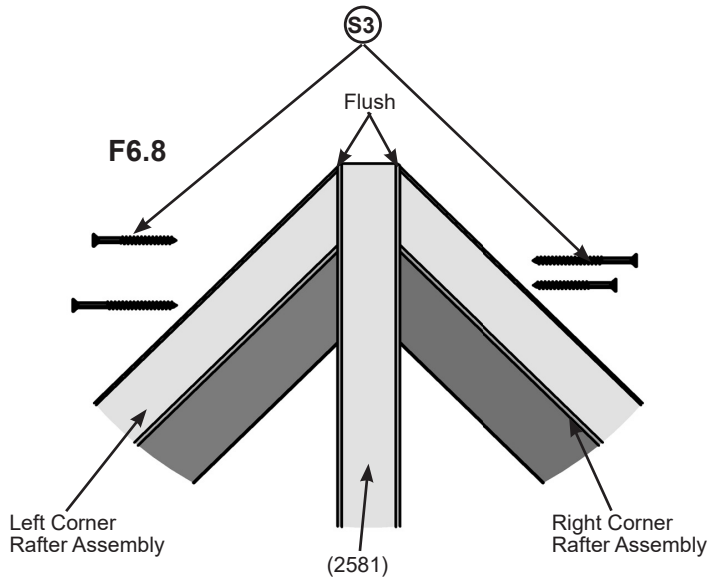
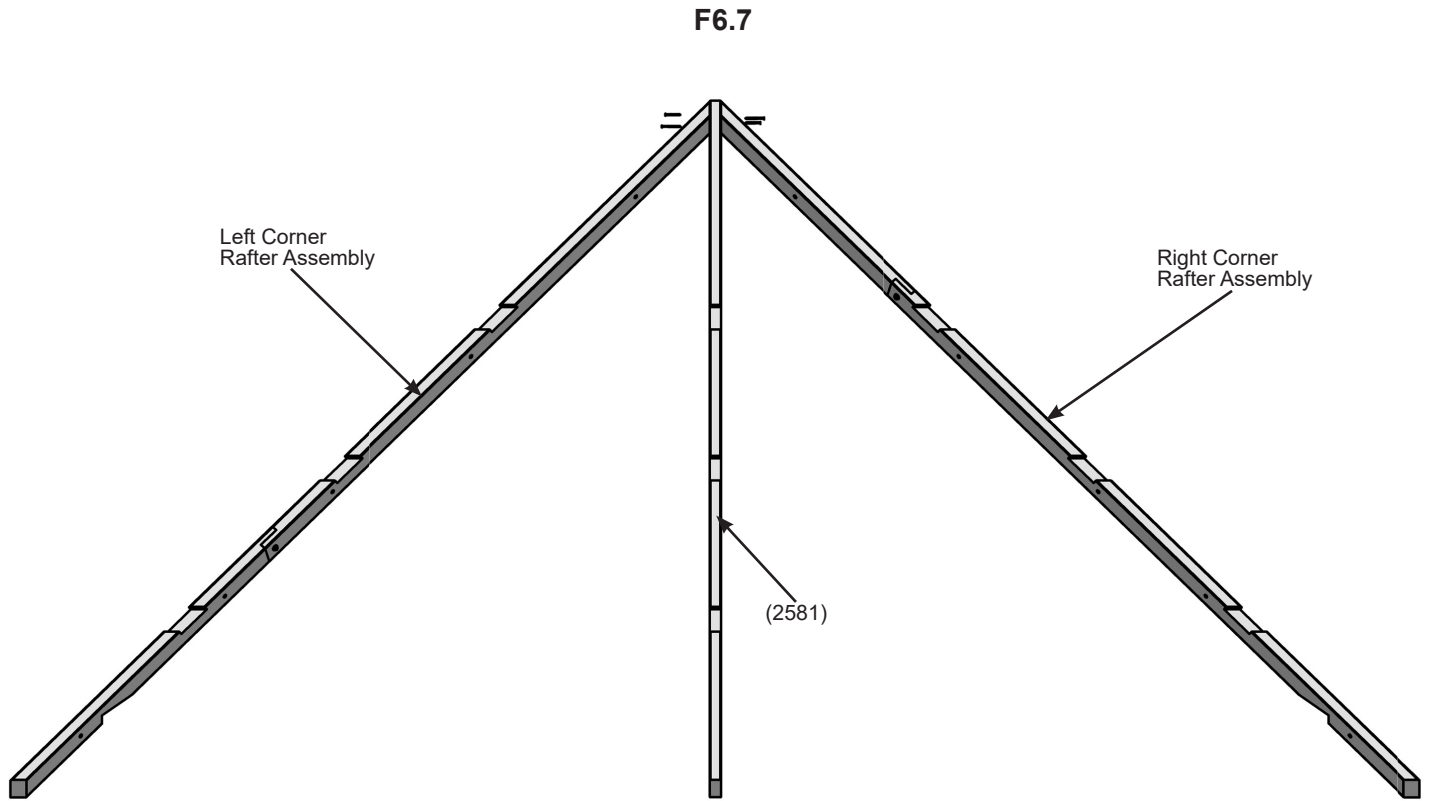

Wood Parts

4 x (2581) Rafter Center

Hardware

16 x **S3** #8 x 2-1/2" Wood Screw

Step 6: Roof Panel Assembly

Part 3

D: Place Fascia Beam Assembly from Part one, on the bottom of the Left Corner Rafter Assembly, Right Corner Rafter Assembly, and the (2581), so the sides are flush and attach using six S3. (F6.10, F6.11)

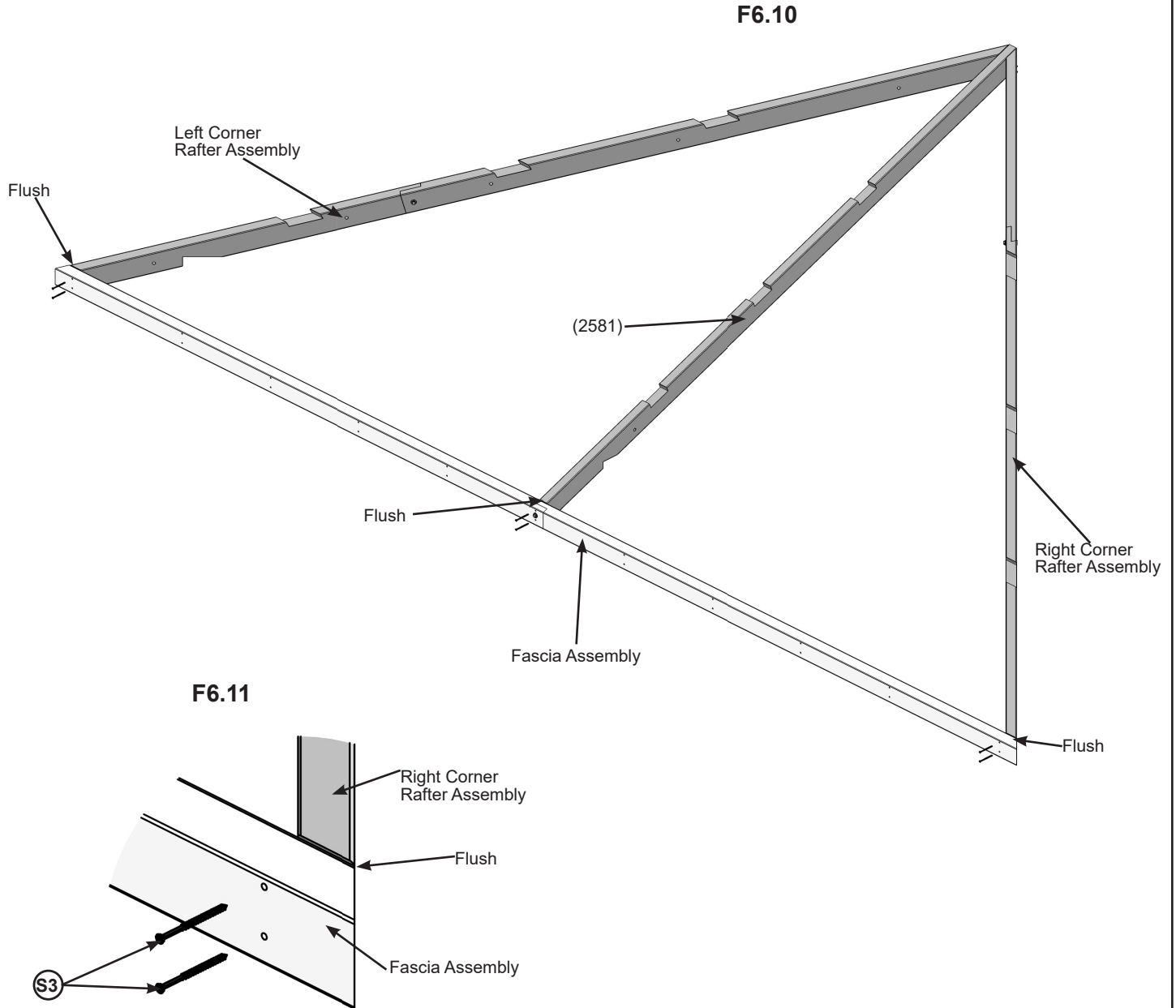

Hardware

24 x **S3** #8 x 2-1/2" Wood Screw

Step 6: Roof Panel Assembly

Part 4

E: Lay out all Rafters as shown in F6.12.

F: Place straps on top, in the grooves of the Rafters and attach using four S2 per Strap, making sure Straps are Flush to the edges of Corner Rafter Assemblies. (F6.12, F6.13 and F6.14)

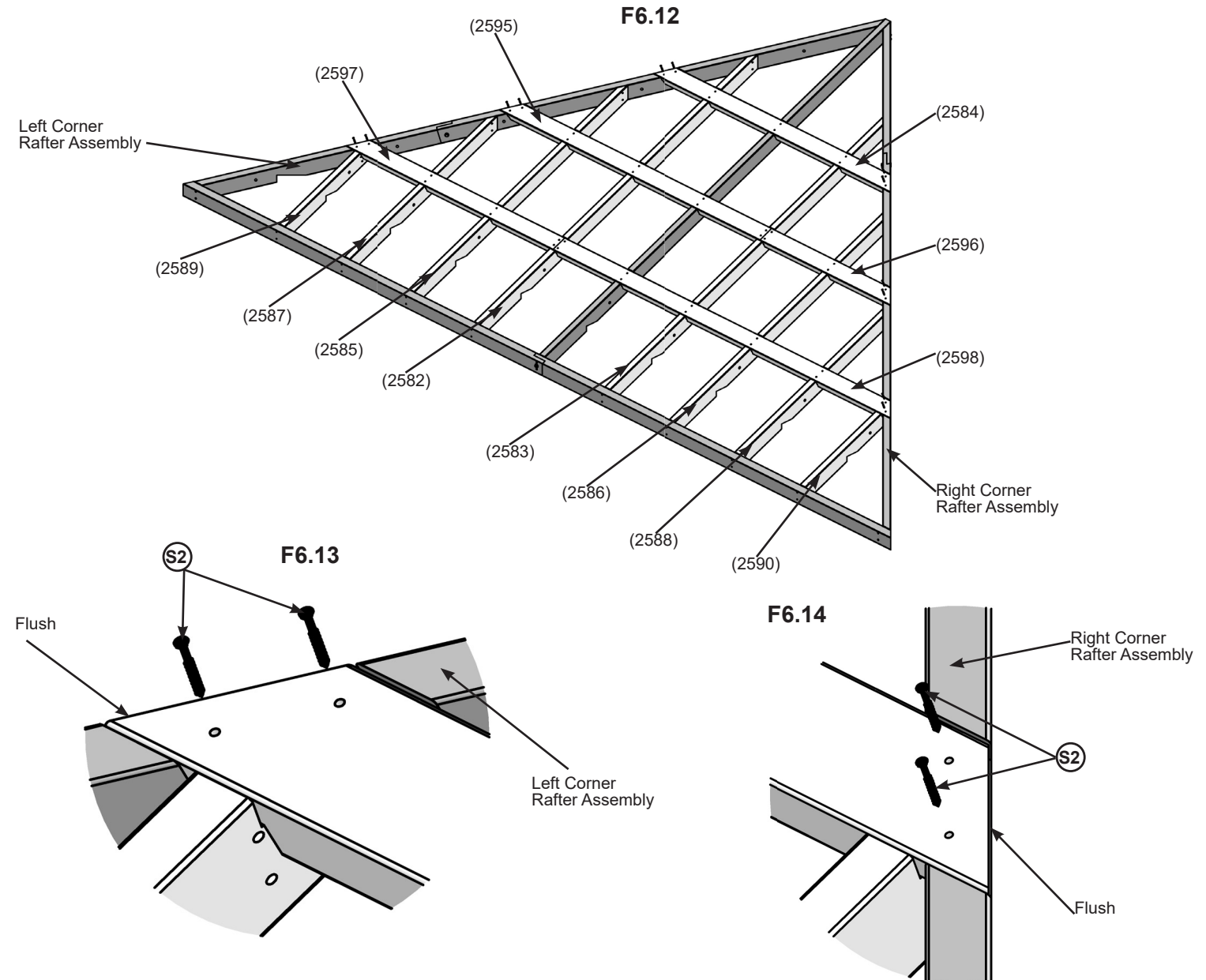

Wood Parts

4 x (2596) Strap Right Short	4 x (2584) Strap	4 x (2583) Rafter Right A
4 x (2597) Strap Left Short	4 x (2582) Rafter Left A	4 x (2586) Rafter Right B
4 x (2598) Strap Right Long	4 x (2585) Rafter Left B	4 x (2588) Rafter Right C
4 x (2595) Strap Left Long	4 x (2587) Rafter Left C	4 x (2590) Rafter Right D
	4 x (2589) Rafter Left D	

Hardware

48 x (S2) #8 x 1-1/2" Wood Screw

Step 6: Roof Panel Assembly

Part 5

G: Flush to the top of Fascia Assembly, center Rafter over pilot holes and attach using two S3 per Rafter. (F6.15, F6.16 and F6.17)

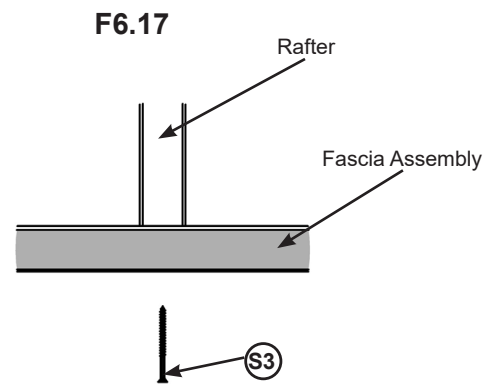
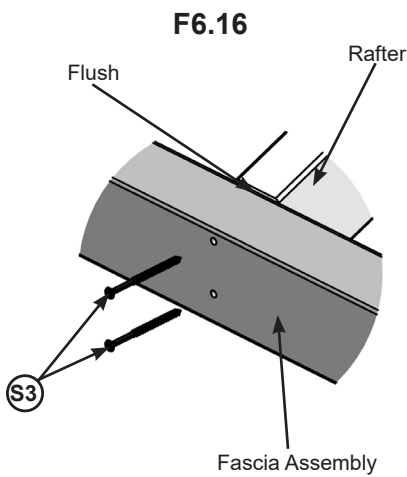
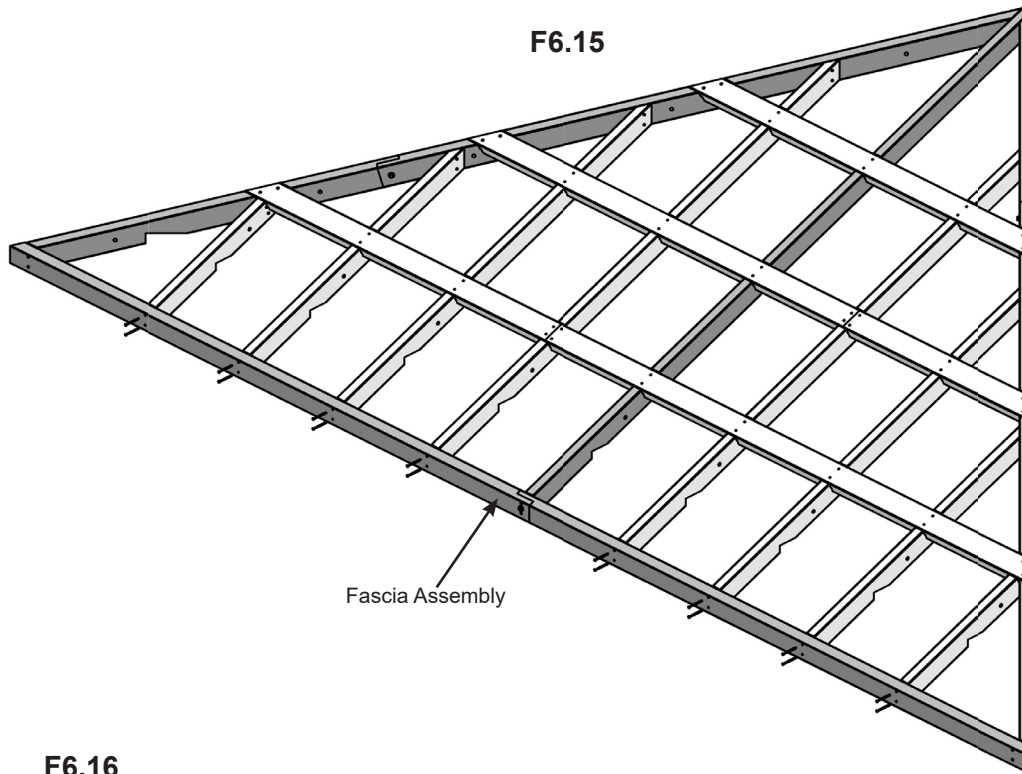

Hardware

64 x **S3** #8 x 2-1/2" Wood Screw

Step 6: Roof Panel Assembly

Part 6

H: Attach Rafters to Corner Rafter Assemblies using two S11 per Rafter. (F6.18, F6.19 and F6.20)

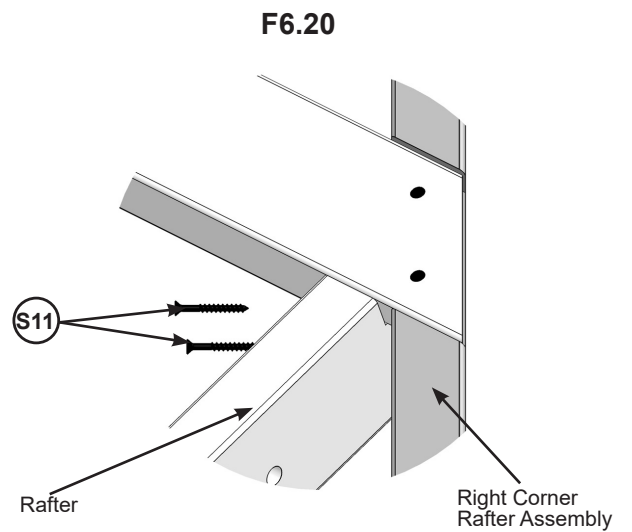
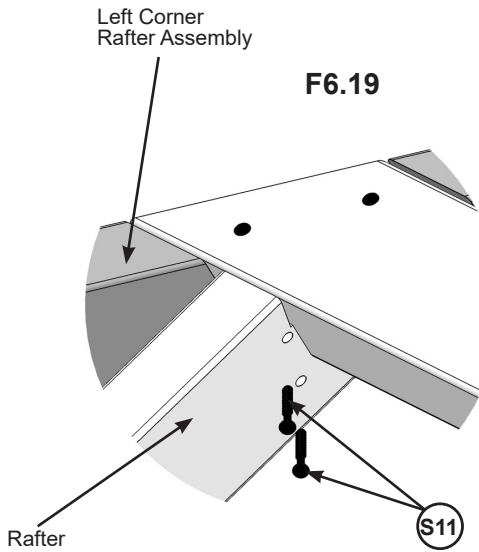
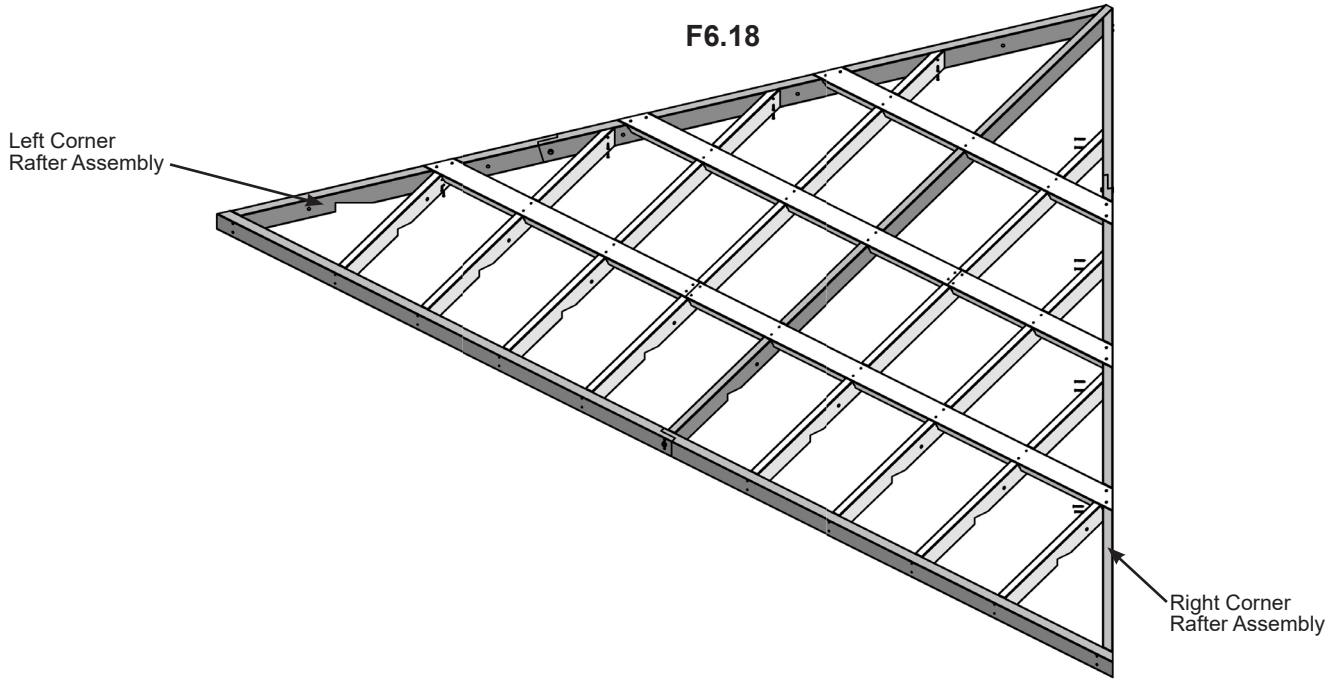

Hardware

64 x **S11** #8 x 2" Wood Screw

Step 6: Roof Panel Assembly

Part 7

I: Attach Straps to Rafters using (34) S2. The screws where the Straps meet are installed on an angle. (F6.21, F6.22 and F6.23)

J: Repeat steps C - I to create three more Roof Panel Assemblies.

F6.21

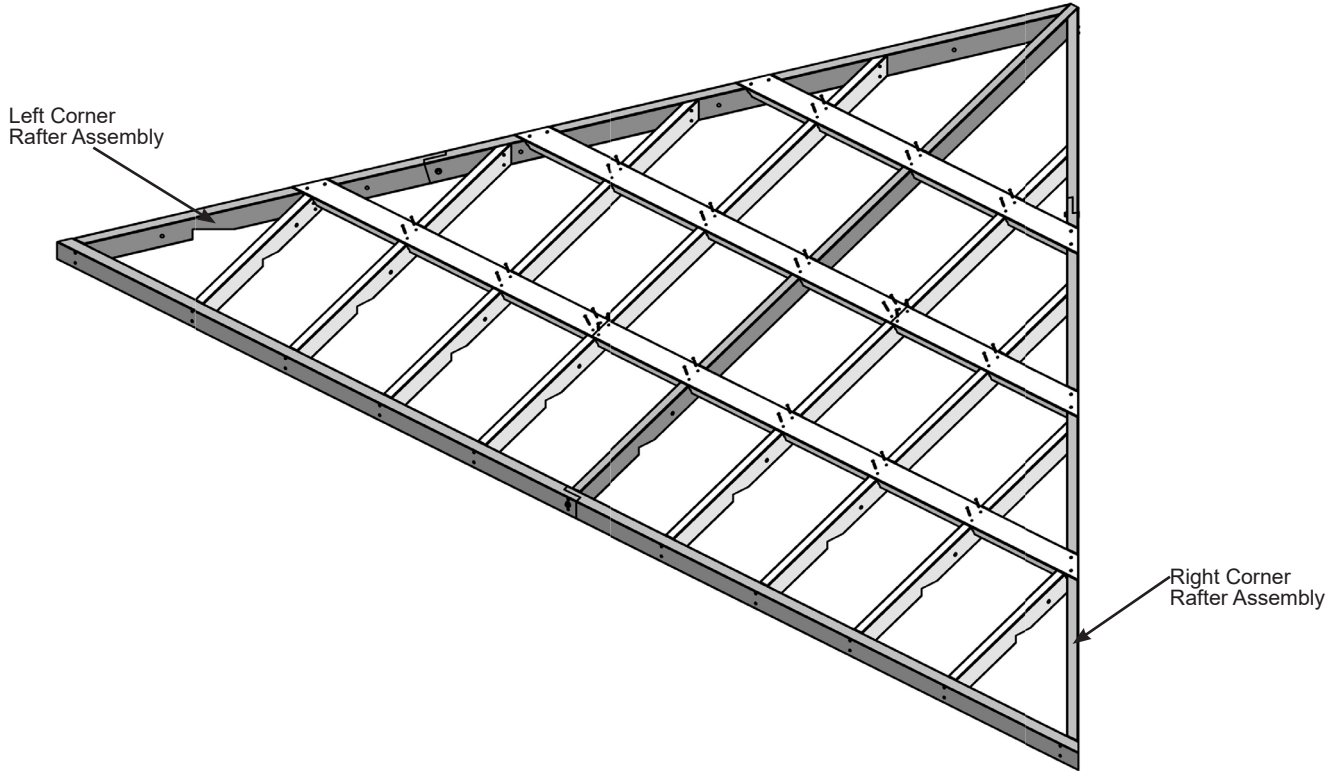

F6.22

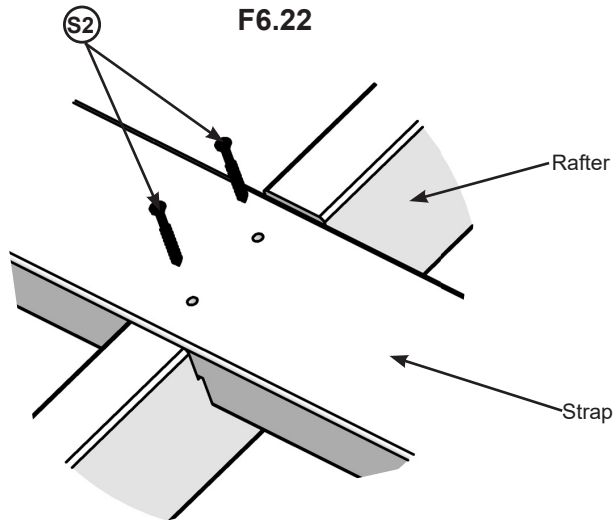

F6.23

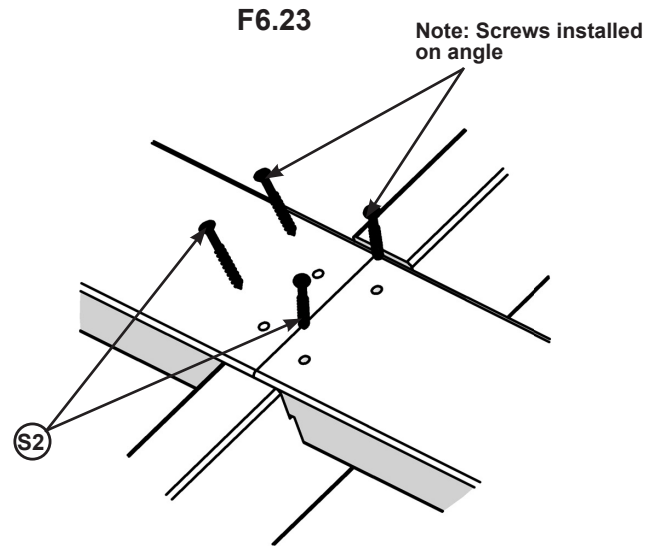

Hardware

136 x S2 #8 x 1-1/2" Wood Screw

Step 6: Roof Panel Assembly

Part 8

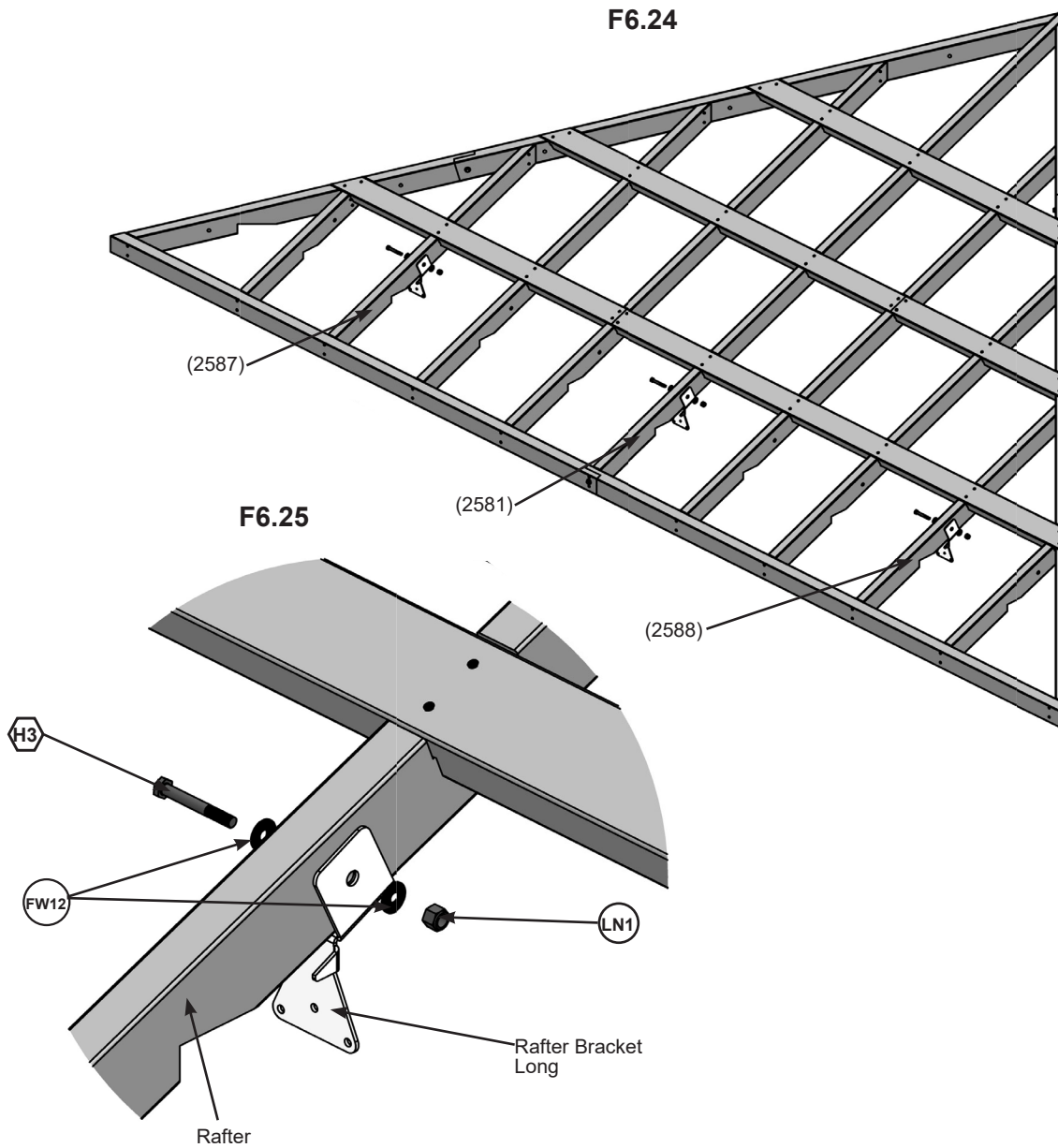

K: On three Roof Panel Assemblies, in the bottom holes of (2587), (2581) and (2588) loosely attach Rafter Bracket Long using one H3 (with FW12 x 2 and LN2) per bracket. (F6.24 and F6.25)



Components

9 x Rafter Bracket Long

Hardware

- 9 x  1/4 x 2-1/2" Hex Bolt
- 9 x  1/4" Lock Nut
- 18 x  1/4-5/16" Large Washer

Step 6: Roof Panel Assembly

Part 9

L: In the pre-drilled holes on the Left and Right Corner Assemblies, place Corner Bracket Rafters so the rounded edge is flush to the outside of the rafter and facing upwards. Attach each bracket using two LS5 (with FW2). Fully tighten each lag, then loosen each one by half a turn. Corner Rafter Brackets will be re-tightened later in the assembly. (F6.26, F6.27 and F6.28)

F6.26

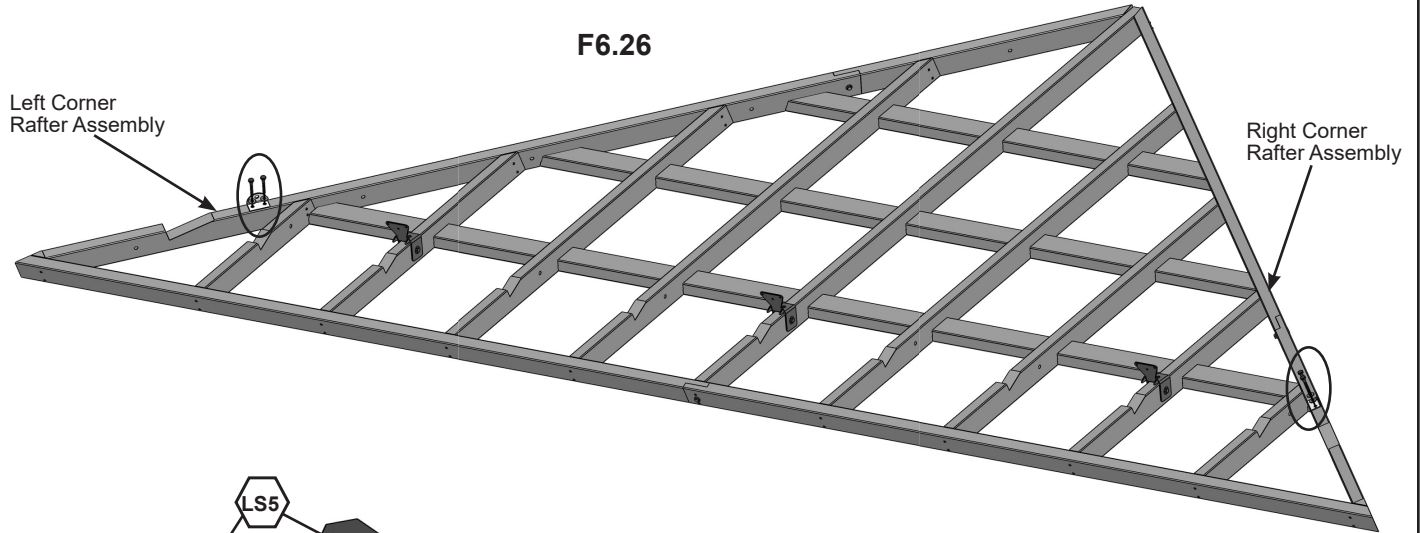

F6.27

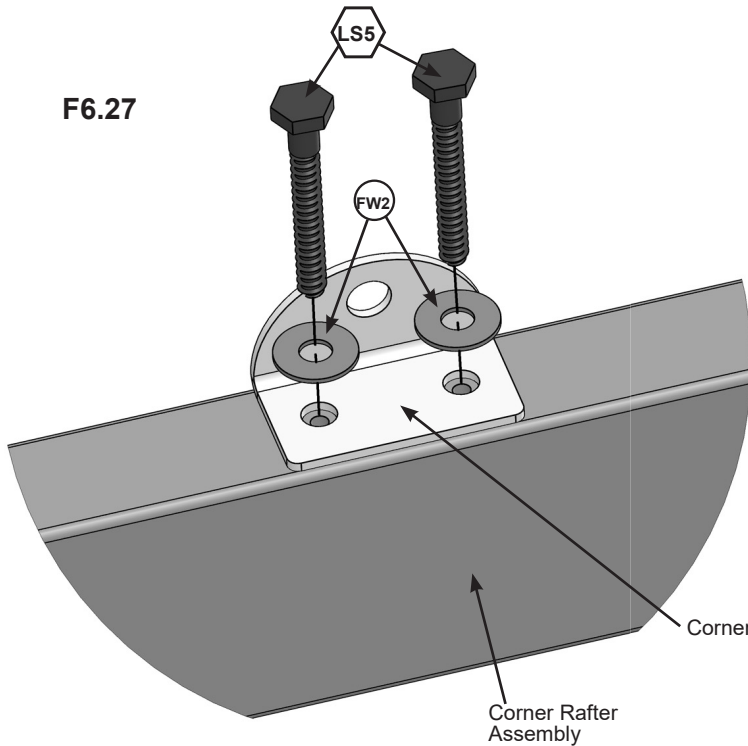

F6.28

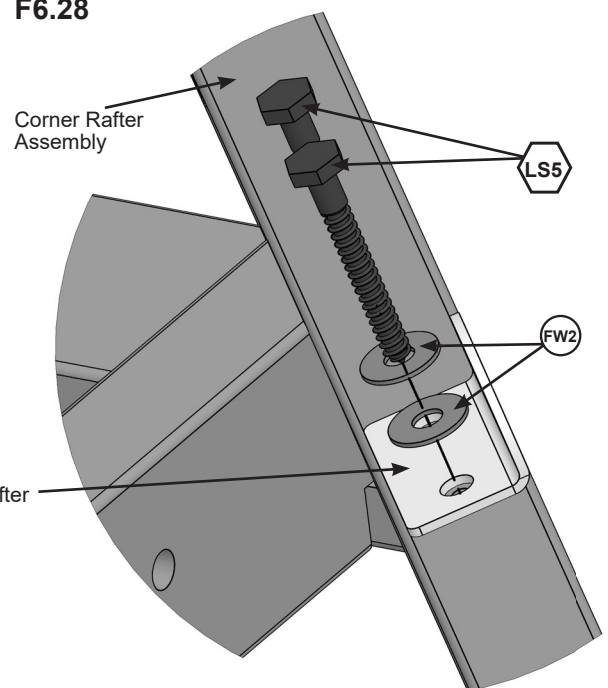

Components

8 x Corner Bracket Rafter

Hardware

16 x  5/16 x 2-1/2" Lag Screw

16 x  5/16" Flat Washer

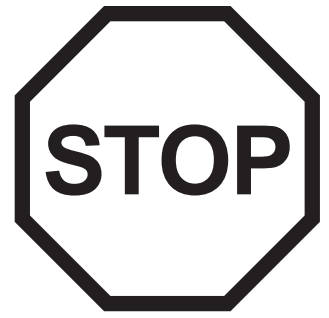
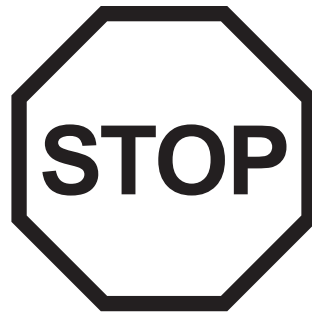
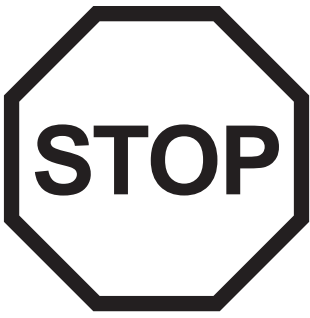

INSTALLING ROOFING MATERIAL

CAUTION!

Roofing material may have sharp edges! Wear gloves!

HANDLE WITH CARE!

Place roofing material on a non-abrasive surface before assembly as it can bend, dent and scratch easily.

**WARNING – DO NOT OVER TIGHTEN ROOFING SCREWS!
Over tightening screws will cause roofing material to crush.**

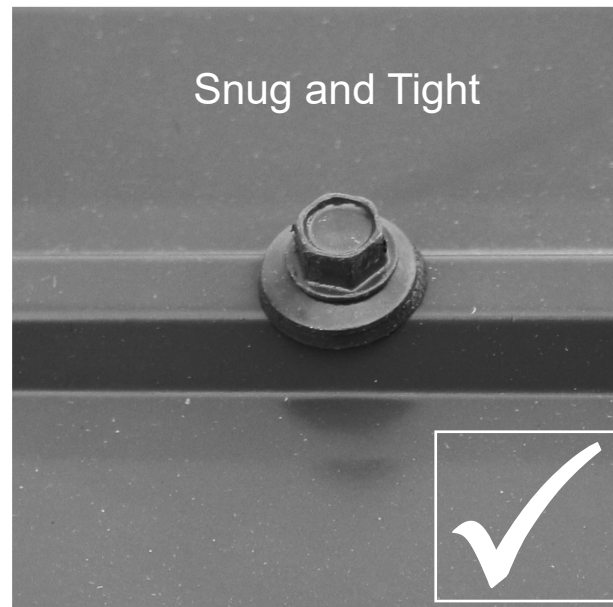

The roofing screws can easily crush the Roof Panels and Roof Edges when using a power drill. We recommend hand tightening the roofing screws so that they sit snug and tight to the roofing material.

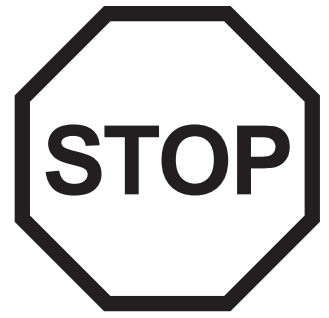
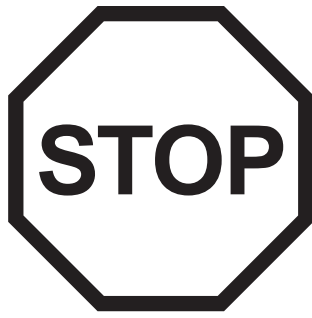
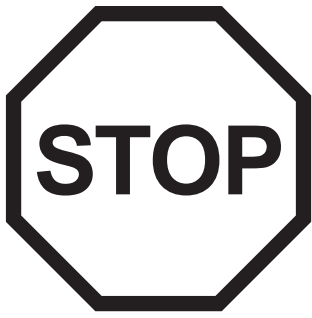

INSTALLING ROOFING MATERIAL

CAUTION!

Roofing material may have sharp edges! Wear gloves!

BE SURE TO REMOVE ALL PLASTIC COVERING, ON BOTH SIDES OF THE ALUMINUM PANELS AND TRIM, DIRECTLY BEFORE INSTALLING EACH PIECE. *(One side is clear and the other is blue, both must be removed.)*

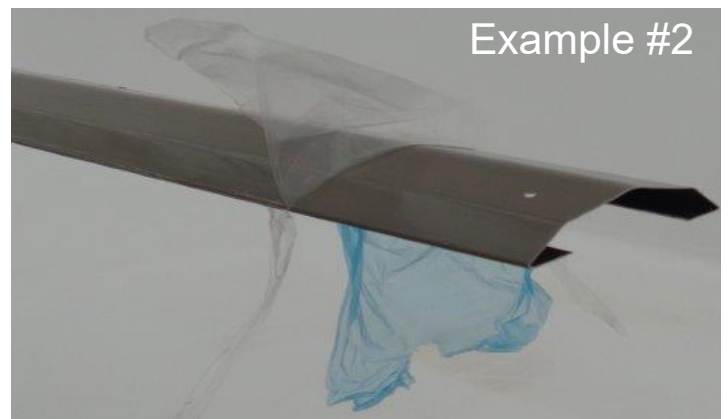
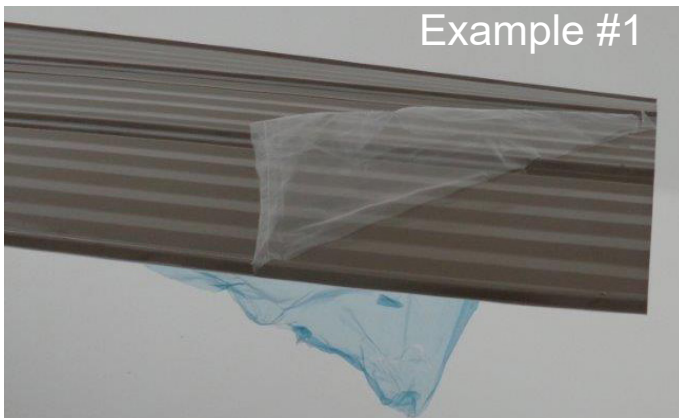

Step 7: Attach Roof Panels

Part 1

Important! Before starting this step be sure to refer back to pages 43 and 44 regarding correct installation and handling of roofing.

A: On one Roof Panel Frame place one Right Long Panel so it is flush to the Right Corner Rafter and a slight overhang at the bottom of the Fascia Beam Assembly. (F7.1)

B: Place one Right Mid Panel and one Right Short Panel beside the Right Long Panel so the panels overlap and screw holes line up and remain flush to the outside of the Right Corner Assembly. Repeat the other side for the Left Long Panel, Left Mid Panel and Left Short Panel. (F7.1 and F7.2)

C: Attach Panels to Roof Panel Frame using eight R0 as shown below. Be sure not to overtighten screws. (F7.1 and F7.2)

D: Repeat Steps A - C for all four Roof Panel Frames.

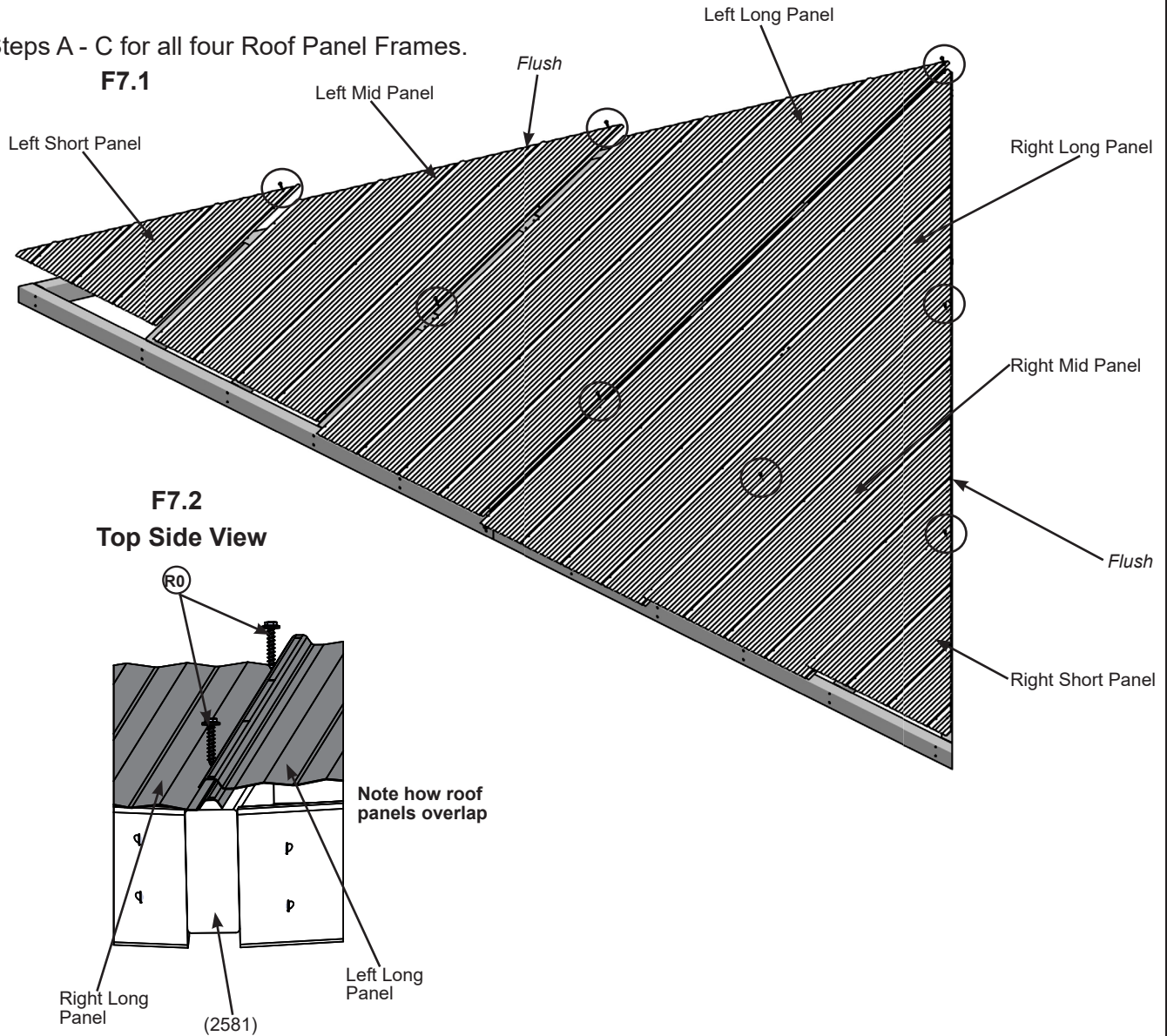

Roof Parts

- | | |
|----------------------|-----------------------|
| 4 x Left Short Panel | 4 x Right Mid Panel |
| 4 x Left Mid Panel | 4 x Right Short Panel |
| 4 x Left Long Panel | |
| 4 x Right Long Panel | |

Hardware

- 32 x  #8 x 1" Hex Roofing Screw

Step 7: Attach Roof Panels Part 2



E: Ensure panels are still flush to the edges and attach panels using (54) R0. (F7.3 and F7.4)

NOTE: Do not attach screws along bottom row

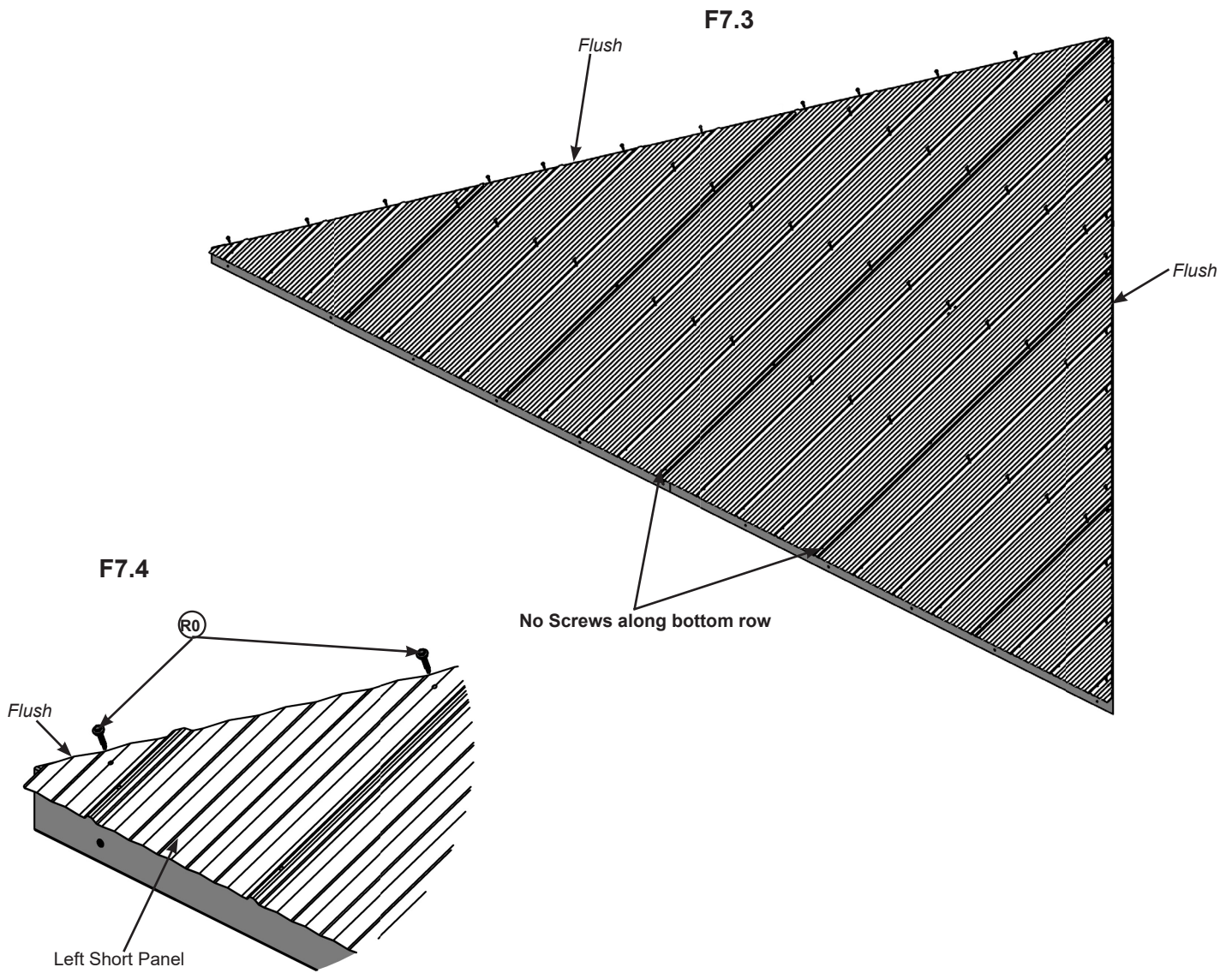

Hardware

216 x R0 #8 x 1" Hex Roofing Screw

Step 7: Attach Roof Panels Part 3

F: Place one Roof Edge Left and one Roof Edge Right on the bottom of each Roof Assembly so the ends are flush with the Fascia Beam Assembly and meet tight in the center. Attach both roof edges with (23) R0. (F7.5, F7.6, F7.7)

G: Repeat for remaining Roof Panel Frames.

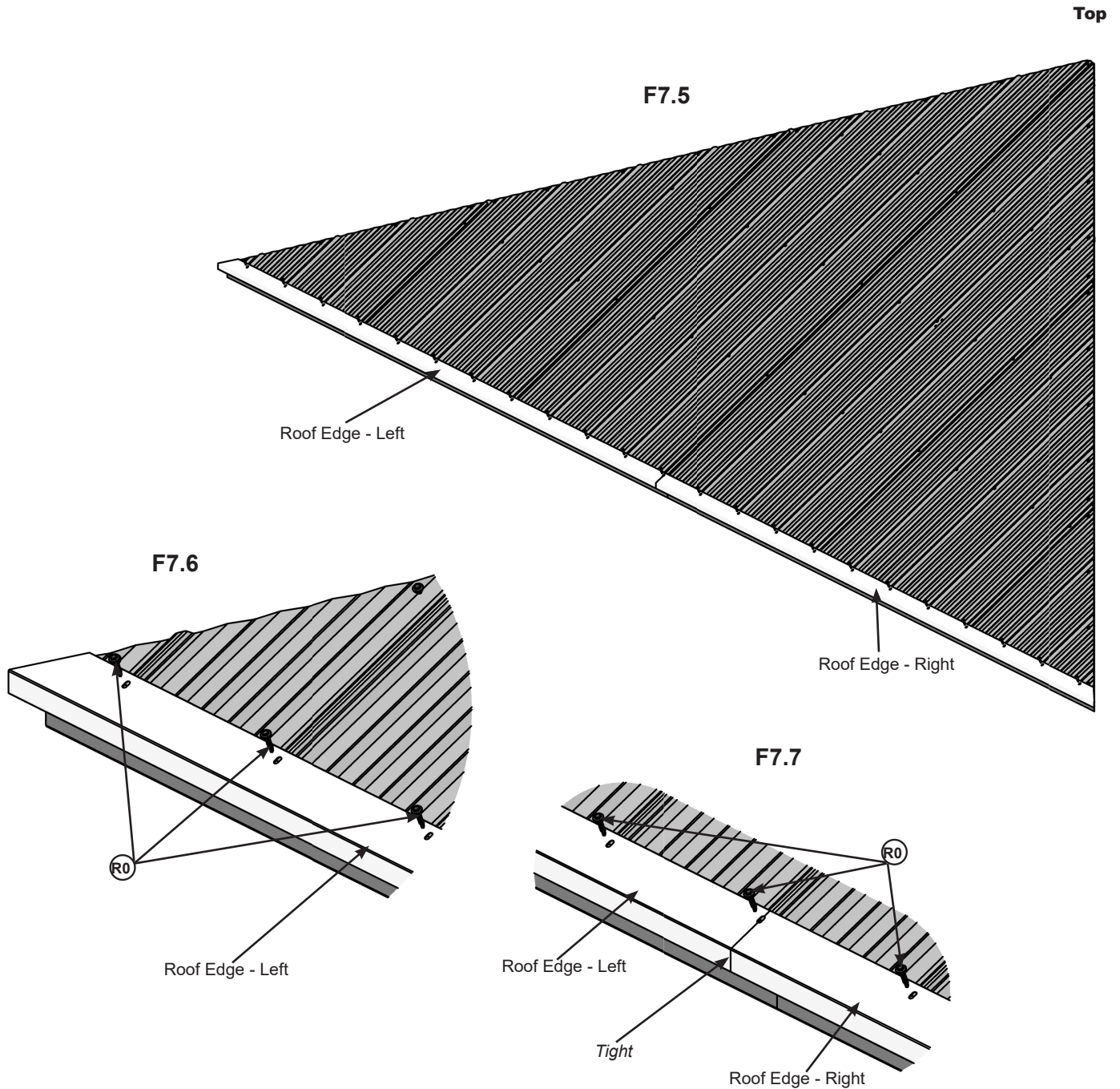

Components

4 x Roof Edge - Left
4 x Roof Edge - Right

Hardware

92 x (R0) #8 x 1" Hex Roofing Screw

Step 7: Attach Roof Panels Part 4



H: Place Weather Seal 1208 on the inside of each Ridge Clip Left, and Weather Seal 2275 on the inside of each Ridge Clip Right, then place a Ridge Clip Right and Ridge Clip Left on each side of Roof Panel so they cover the Roof Panel and the bottom edge is 4" (101.6mm) up from the bottom of Corner Rafter Assembly. Attach with eight S39 per side. (F7.8, F7.9, F7.10, and F7.11)

I: Repeat for remaining Roof Panel Frames. **Note placement of Ridge Clips**

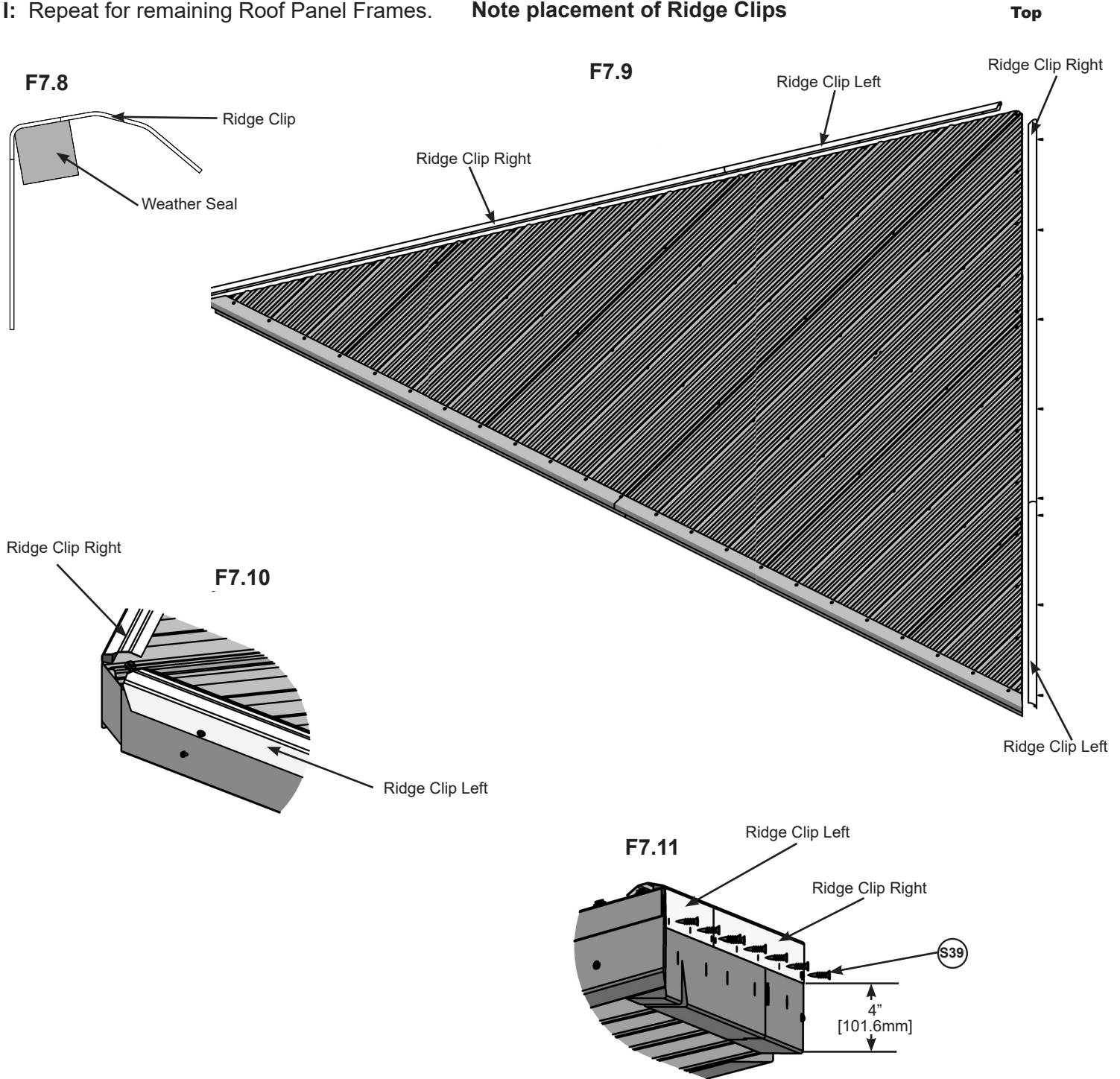

Components

8 x Ridge Clip Left
8 x Ridge Clip Right
8 x Weather Seal 1208
8 x Weather Seal 2275

Hardware

64 x S39 #7 x 3/4" Wood Screw

Step 8: Attach Roof Panels to Frame Part 1

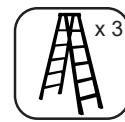

A: With four assemblers lift one Roof Panel Frame with Rafter Bracket Long installed, up and over the gazebo frame so notches in the rafters sit tight on the Beam Assemblies. (F8.1, F8.2)

B: Lift a second Roof Panel Frame with Rafter Bracket Long installed, up and over the gazebo frame so it rests on the Beam Assembly making sure Panel Frames are tight together and notches are tight to Beam Assemblies. **One assembler must remain on a ladder to hold Roof Panel Frame in place until secured.** (F8.3)

C: Loosely attach each Rafter Corner Assembly together with five G21 (with FW12 x 2 and LN2). (F8.3, F8.4 and F8.5)

F8.1

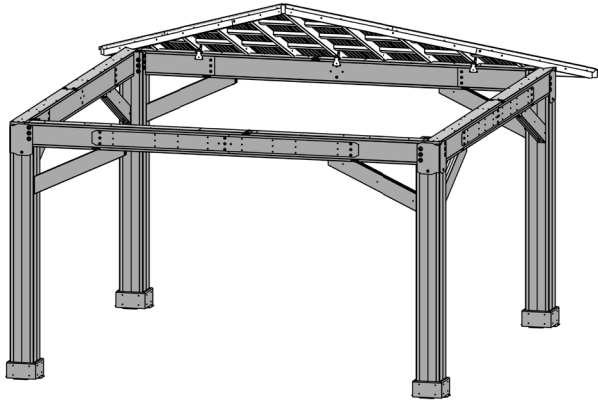

F8.3

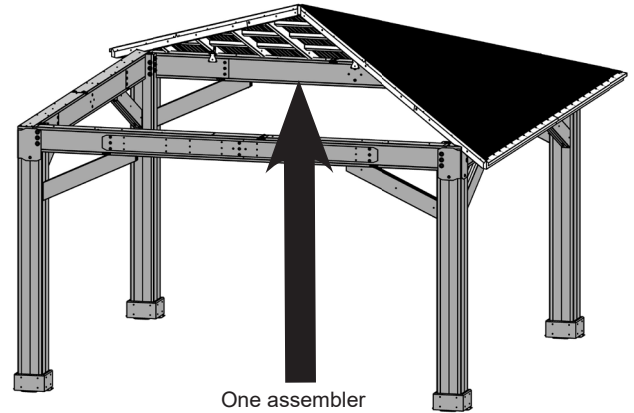

One assembler to support roof panel(s) at all times until secure

F8.4

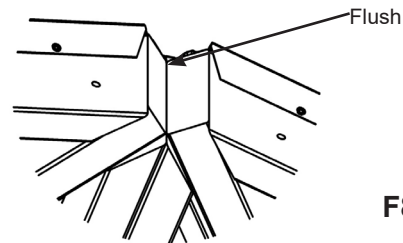

Flush

F8.2

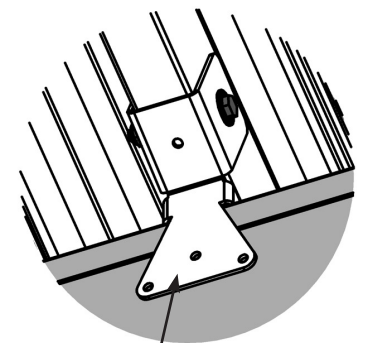

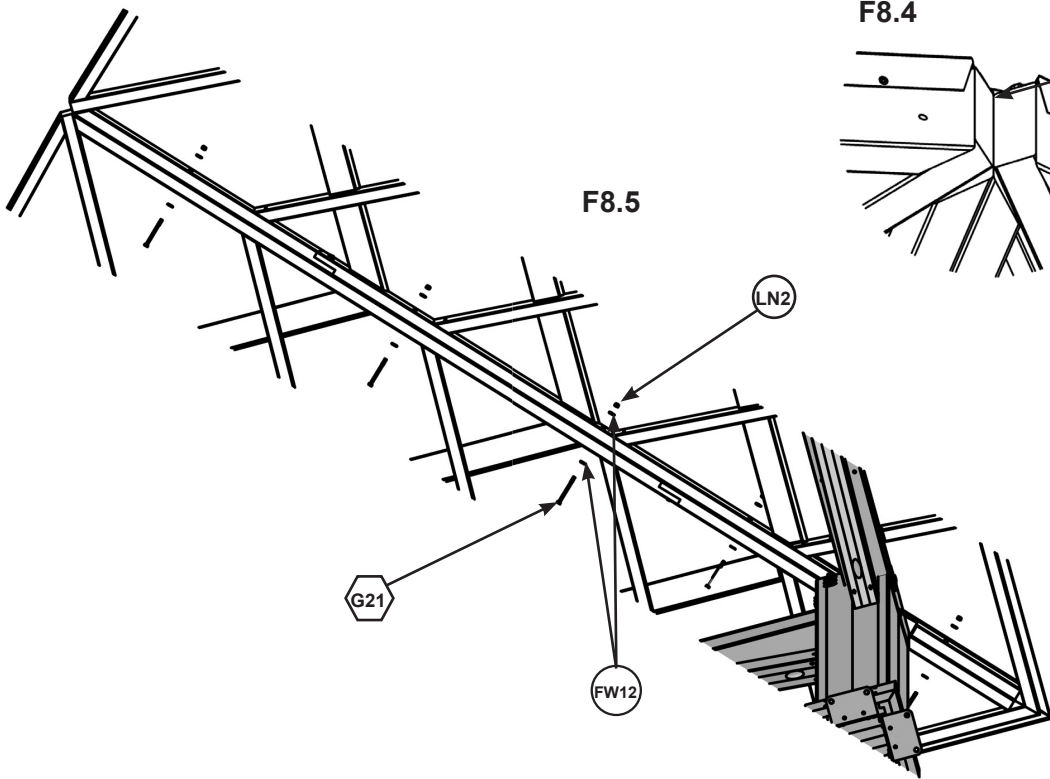

Rafter Bracket Long

F8.5



Hardware

- 5 x  5/16 x 3-3/4" Hex Bolt
- 5 x  5/16" Lock Nut
- 10 x  1/4-5/16" Large Washer

Step 8: Attach Roof Panels to Frame Part 2

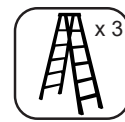

D: Lift a third Roof Panel Frame with Rafter Bracket Longs installed, up and over the gazebo frame taking care not to drag the Panel on the beams, so it rests on the Beam Assembly making sure Panel Frames are tight together and notches are tight to Beam Assemblies. Loosely attach each Rafter Corner Assembly together with five G1 (with FW12 x 2 and LN2). (F8.6, F8.7 and F8.8) **One assembler must remain on a ladder to hold Roof Panel Frame in place until secured.**

F8.6

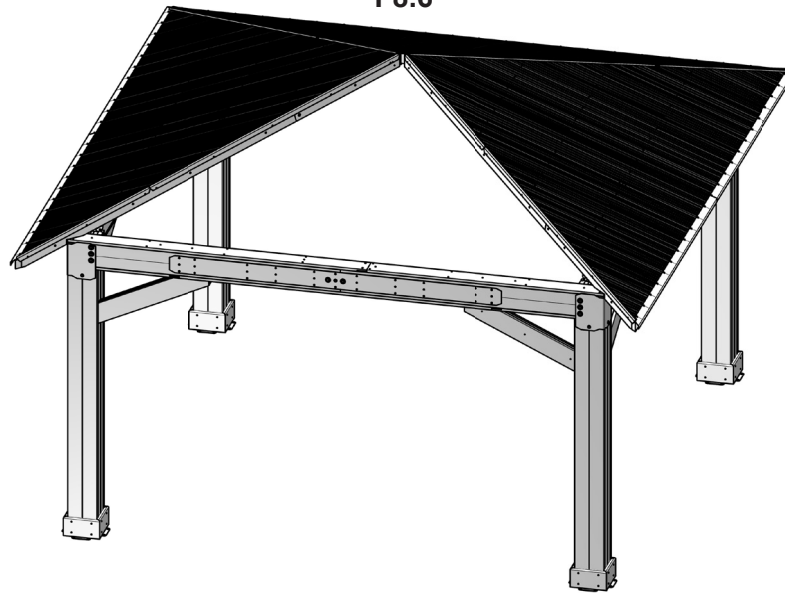

F8.7

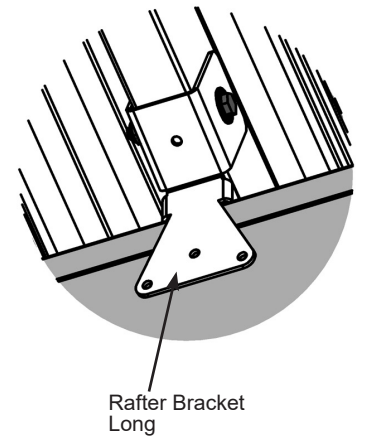

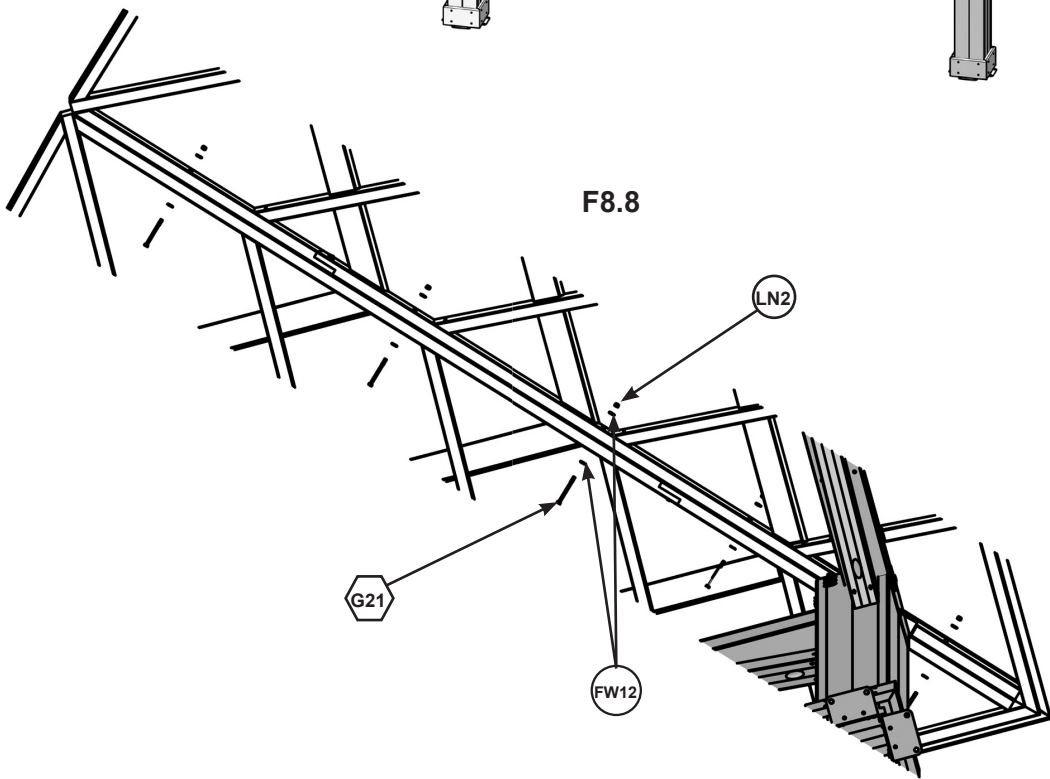

Rafter Bracket Long

F8.8



Hardware

- 5 x  5/16 x 3-3/4" Hex Bolt
- 5 x  5/16" Lock Nut
- 10 x  1/4-5/16" Large Washer

Step 8: Attach Roof Panels to Frame Part 3

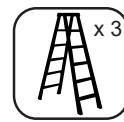

E: Install Roof Peak Assembly by inserting Carriage Bolt through the Contour Washer into the top of the Peak Cap into the Peak Post then the Spring Clip. **Spring clip holds the assembly together.** (F8.9)

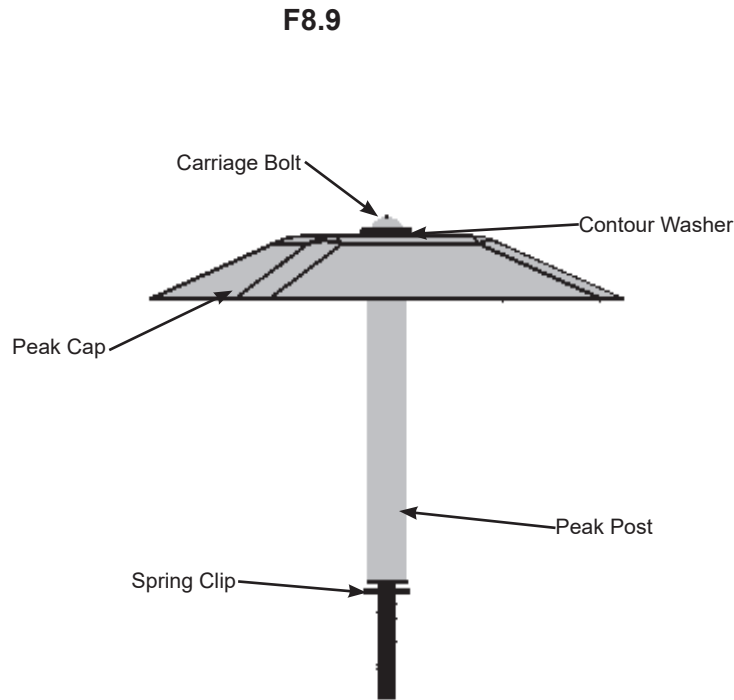

Components

- | | |
|--------------------|---------------|
| 1 x Roof Peak Set | 1 x Peak Cap |
| 1 x Carriage Bolt | |
| 1 x Spring Clip | 1 x Peak Post |
| 1 x Contour Washer | |

Step 8: Attach Roof Panels to Frame Part 4



F: Place the Post Block into the gap between the Roof Panels, then insert Roof Peak Assembly into the hole in the Post Block. Insert both Roof Peak Brackets through the carriage bolt then loosely attach using one WN1. (F8.10 and F8.11)

G: Loosely attach both Roof Peak Brackets to the rafter corner assembly in the slotted holes with two S10 as shown in F8.12. **Loosely attach hardware.** Tightening will occur at a later step. (F8.10, F8.11, F8.12 and F8.13)

F8.10

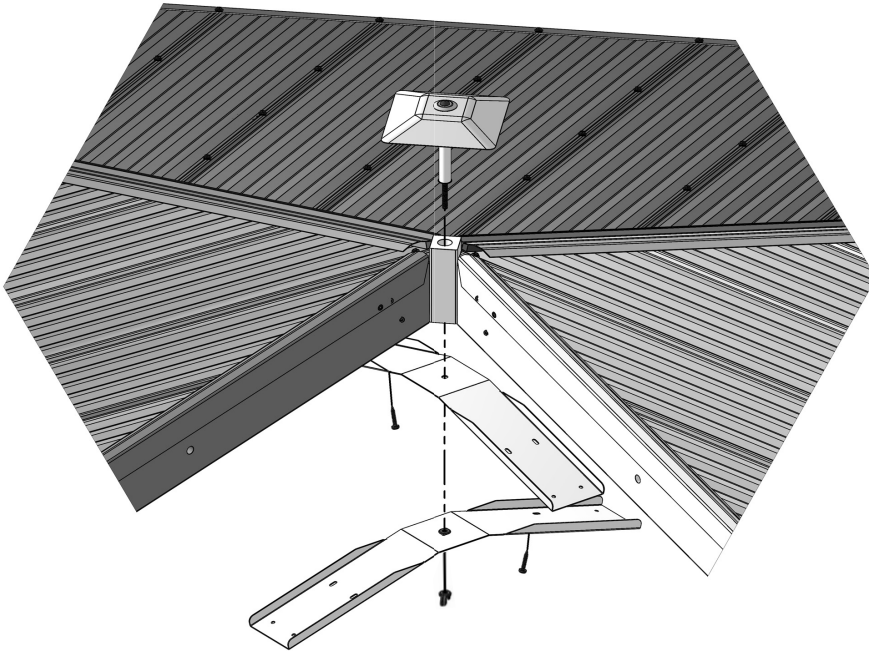

F8.11

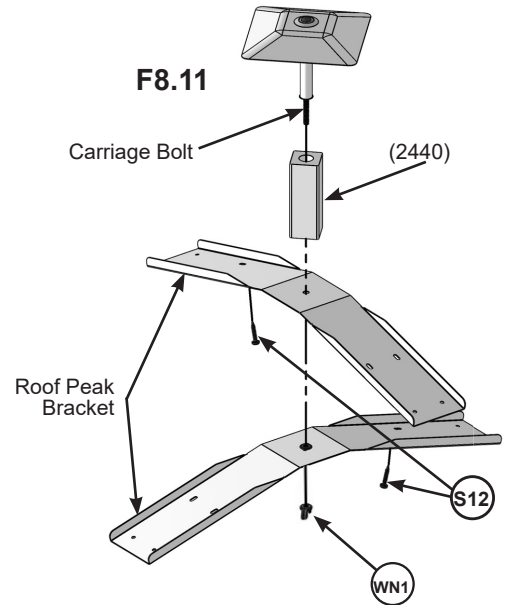

F8.13

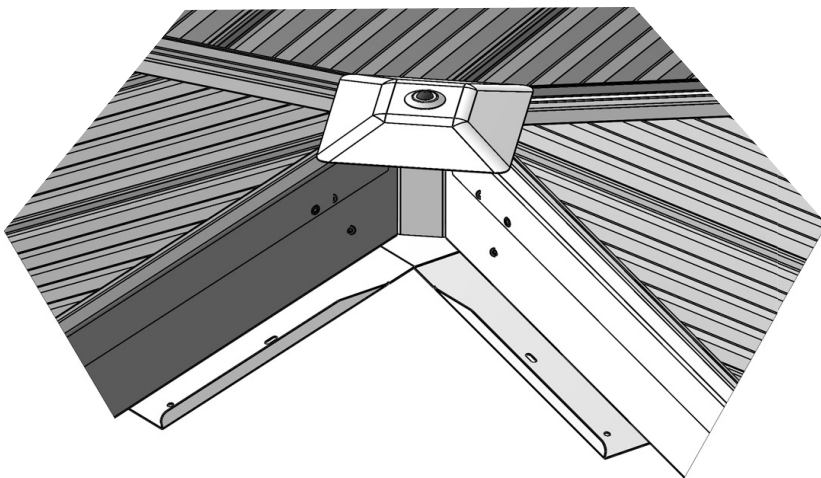

F8.12

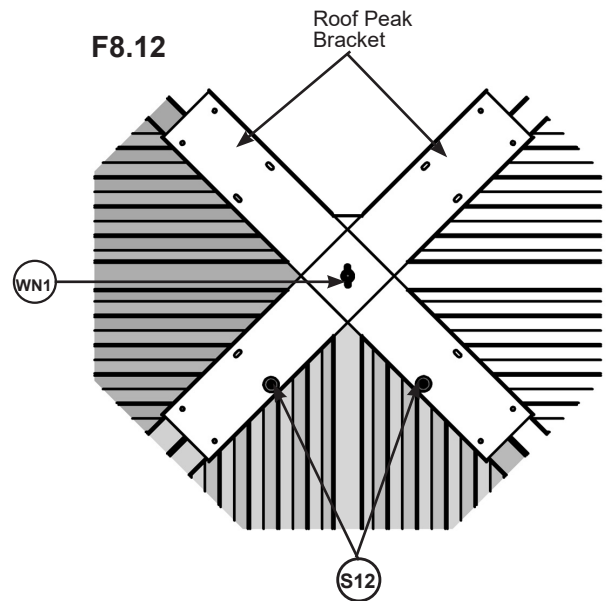

Wood Parts

1 x (2440) Post Block

Components

2 x Roof Peak Bracket

Hardware

1 x (WN1) Lock Wing Nut

2 x (S12) #10 x 1-1/4" Pan Screw

Step 8: Attach Roof Panels to Frame

Part 5

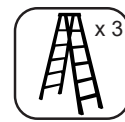

H: Lift last Roof Panel Assembly without Rafter Bracket Longs over Beam Assembly taking care not to drag the panel on the beams. Panel fits under the Peak Cap, push up on Carriage Bolt to lift Peak Cap. The centre of the other panels may have to be pushed up to fit fourth panel. (F8.13, F8.14)

I: Check that the Peak Cap is lined up with Rafter Corners.

J: Starting at the bottom and working up loosely connect Roof Panel Assemblies through the Rafter Corner Assembly together with five G21 (with FW12 x 2 and LN2) per side. To align bolt holes, the helper on the centre ladder may have to push up in the centre of the panels and others make sure corners are aligned. Tighten bolts when all twenty have been installed. (F8.15 and F8.16)

Rafter Corners Assemblies should be aligned with Posts.

F8.13

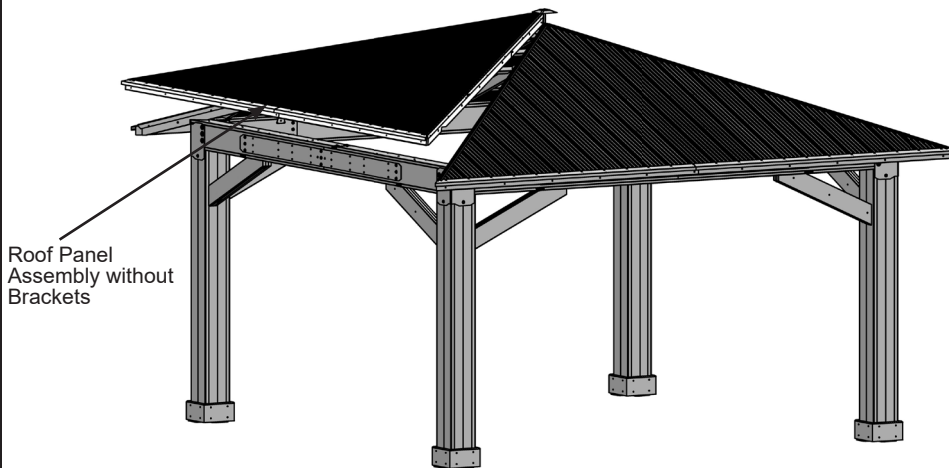
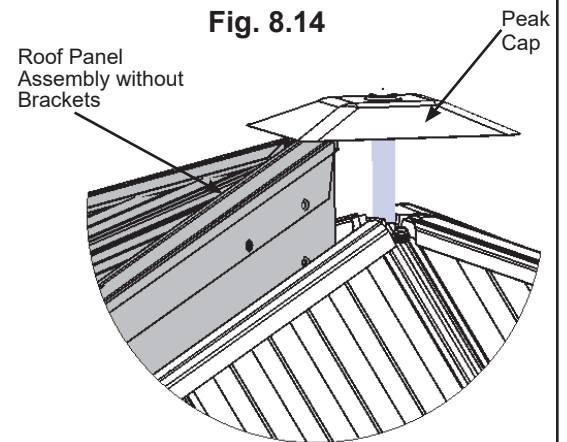
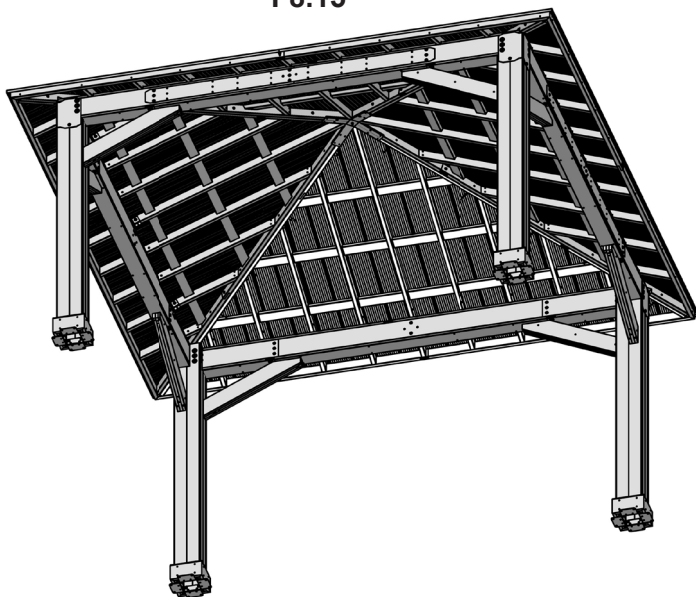

Fig. 8.14



F8.15



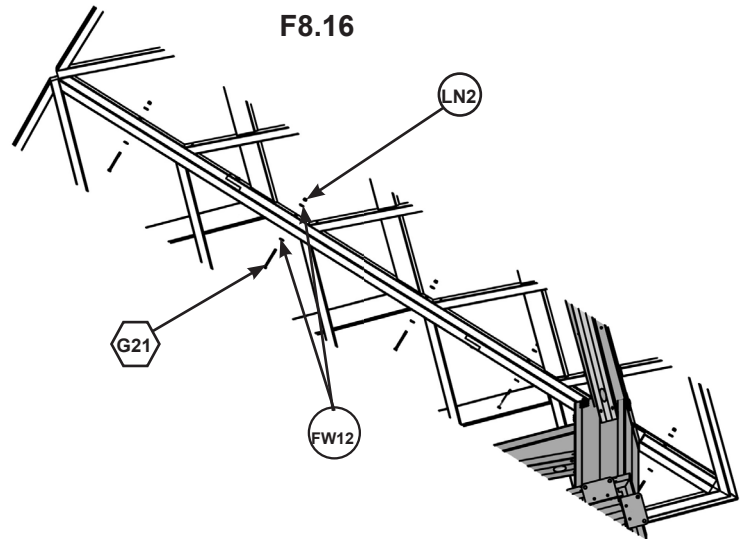

F8.16



Hardware

10 x  5/16 x 3-3/4" Hex Bolt

10 x  5/16" Lock Nut

20 x  1/4-5/16" Large Washer

Step 8: Attach Roof Panels to Frame Part 6

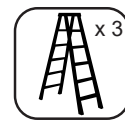

K: For the final roof panel assembly, use one H3 (with FW12 x 2 and LN1) per bracket to loosely attach one Roof Bracket Long to each rafter through the bolt hole located at the bottom of the rafter. (F8.17 and F8.18)

F8.17

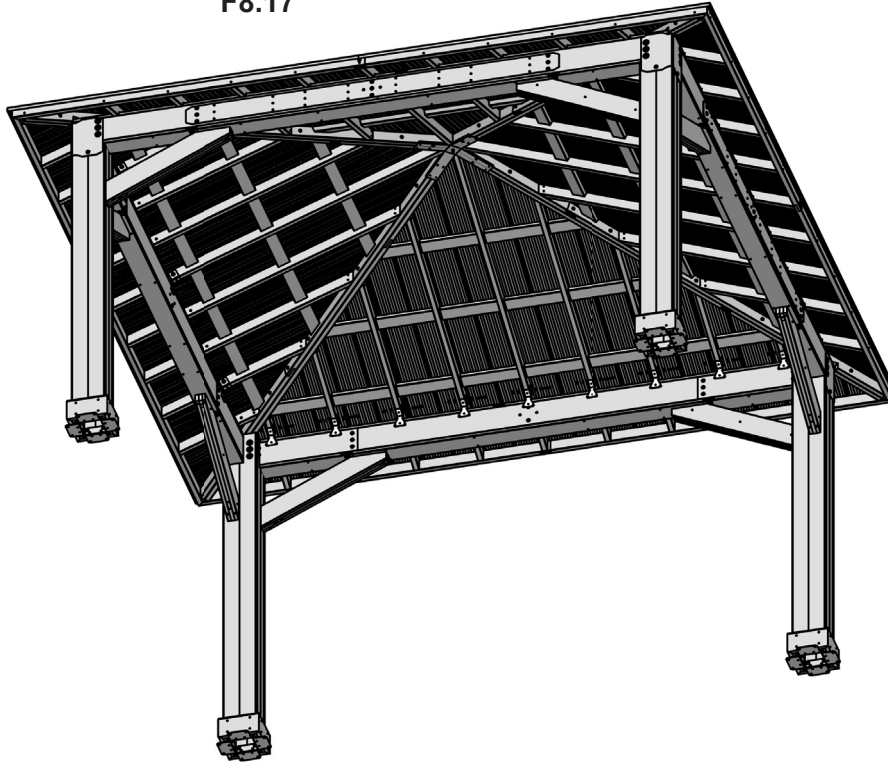

F8.18

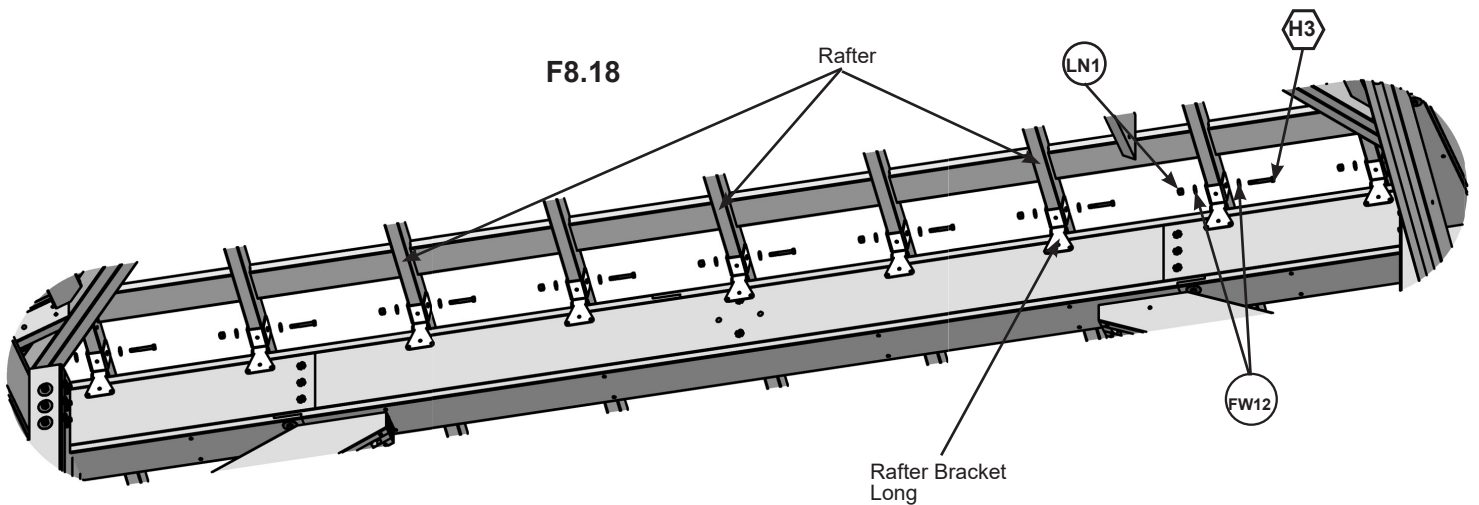

Components

9 x Rafter Bracket Long

Hardware

9 x H3 1/4 x 2-1/2" Hex Bolt

9 x LN1 1/4" Lock Nut

18 x FW12 1/4-5/16" Large Washer

Step 8: Attach Roof Panels to Frame Part 7



L: On the remaining three Roof Panel Assemblies, through the bolt hole at the bottom of the rafters, loosely attach one Roof Bracket Long to each rafter with one H3 (with FW12 x 2 and LN1) per bracket. (F8.19 and F8.20)

F8.19

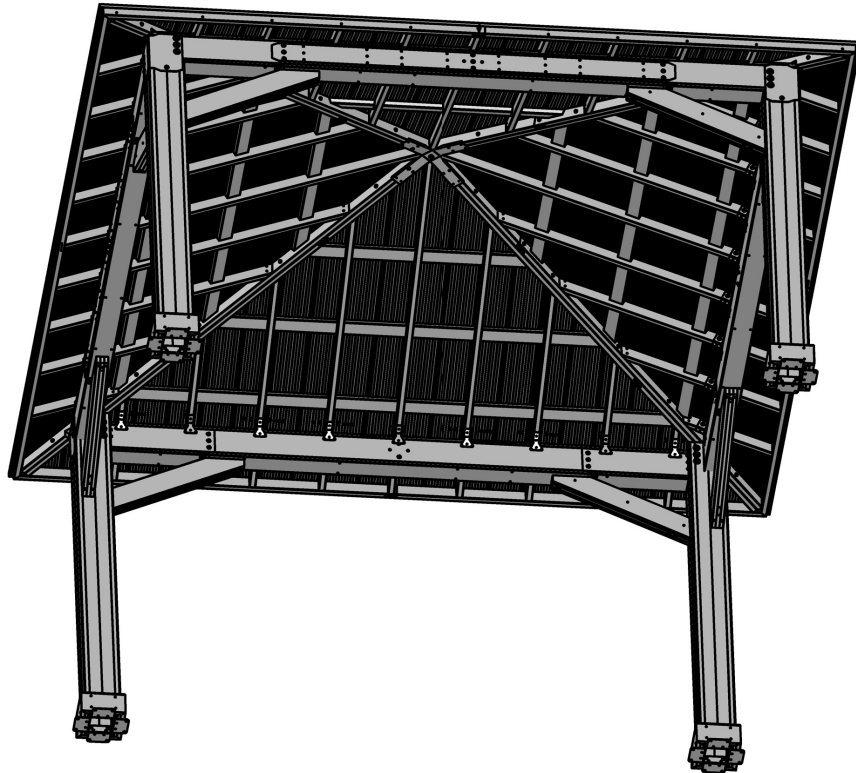

F8.20

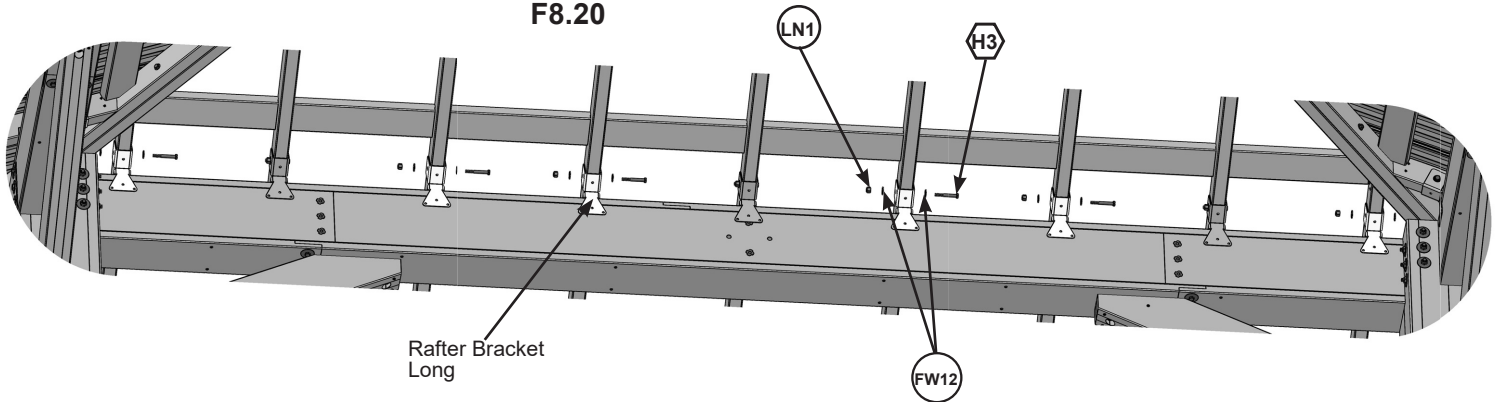

Rafter Bracket Long

Components

18 x Rafter Bracket Long

Hardware

18 x  1/4 x 2-1/2" Hex Bolt

18 x  1/4" Lock Nut

36 x  1/4-5/16" Large Washer

Step 8: Attach Roof Panels to Frame Part 8



M: On top of each Post, place a Corner Bracket Post so the Corner Bracket Rafters fit between the space in the bracket and the bolt holes line up. Loosely attach all brackets together with one G2 (with FW2 x 2 and LN2) per bracket. (F8.21 and F8.22)

F8.21

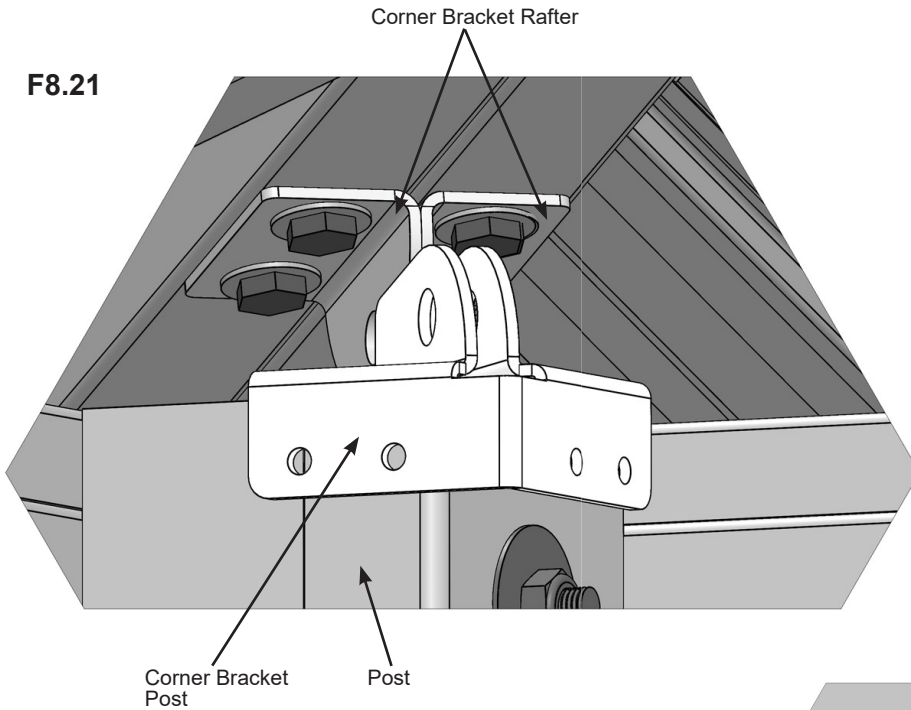

F8.22

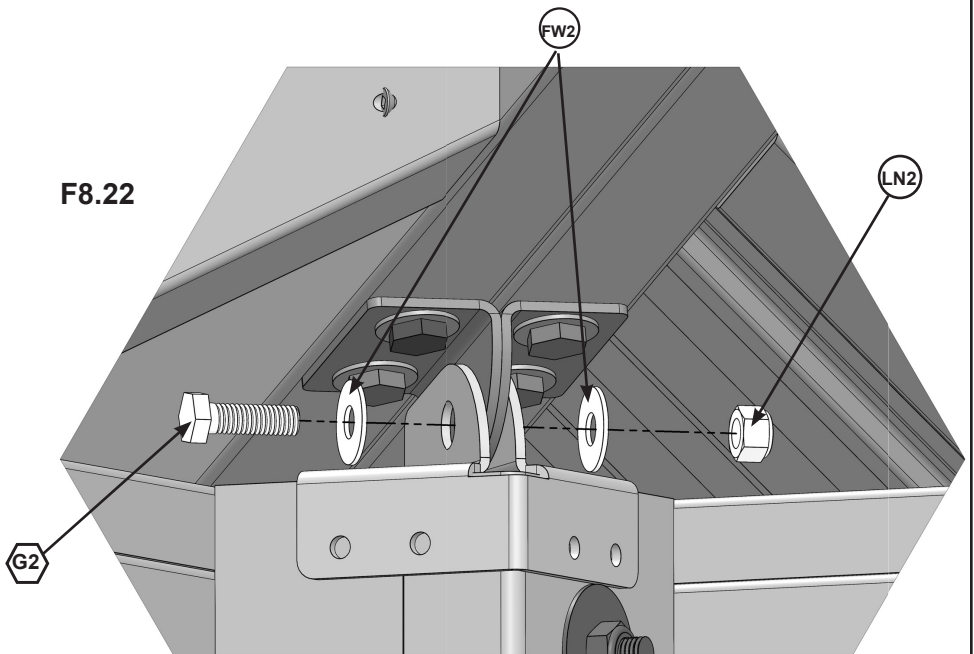

Components

4 x Corner Bracket Post

Hardware

4 x  5/16 x 1" Hex Bolt

4 x  5/16" Lock Nut

8 x  5/16" Flat Washer

Step 8: Attach Roof Panels to Frame Part 9



N: Check that the Corner Bracket Posts are tight to the top and sides, then attach each bracket with four S12.
(F8.23)

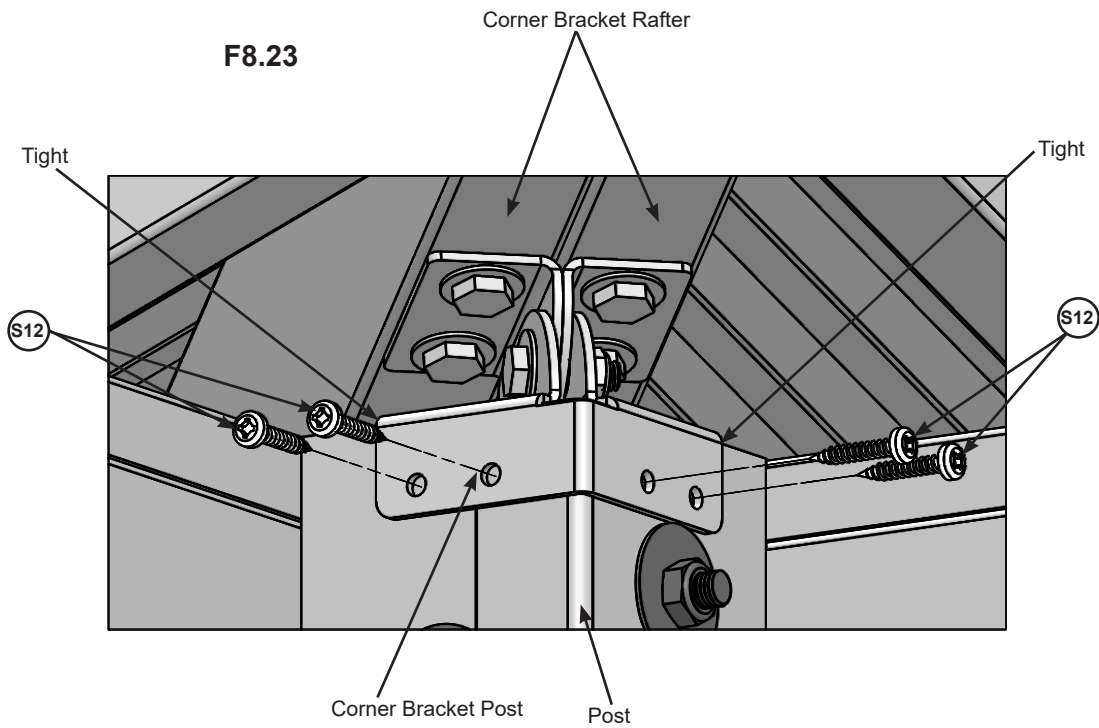

Hardware

16 x  #10 x 1-1/4" Pan Screw

Step 8: Attach Roof Panels to Frame

Part 10



O: Adjust the panels by pushing them up from the outside and inside so the notch in each Rafter is close to the Short Beam Assemblies and Long Beam Assemblies. Once in place, fasten each Rafter Bracket Long with four S12 per bracket. (F8.24, F8.25 and F8.26)

Once screws are installed tighten all bolts in Rafter Bracket Longs.

F8.26

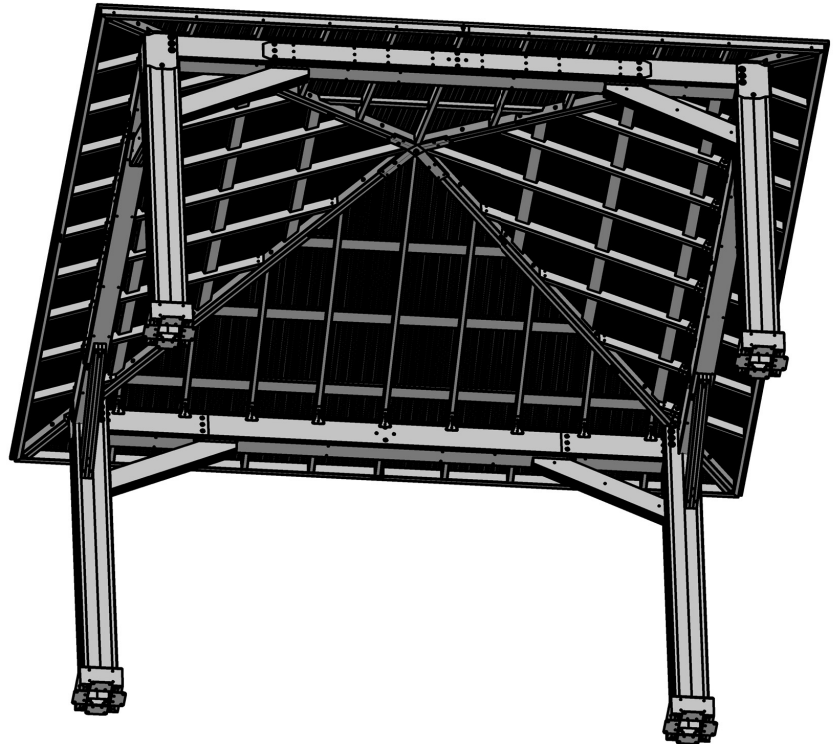

F8.25

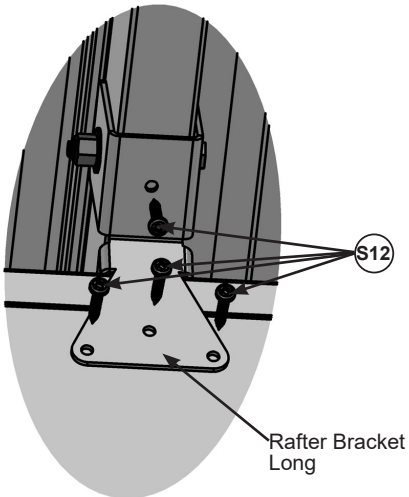

F8.24

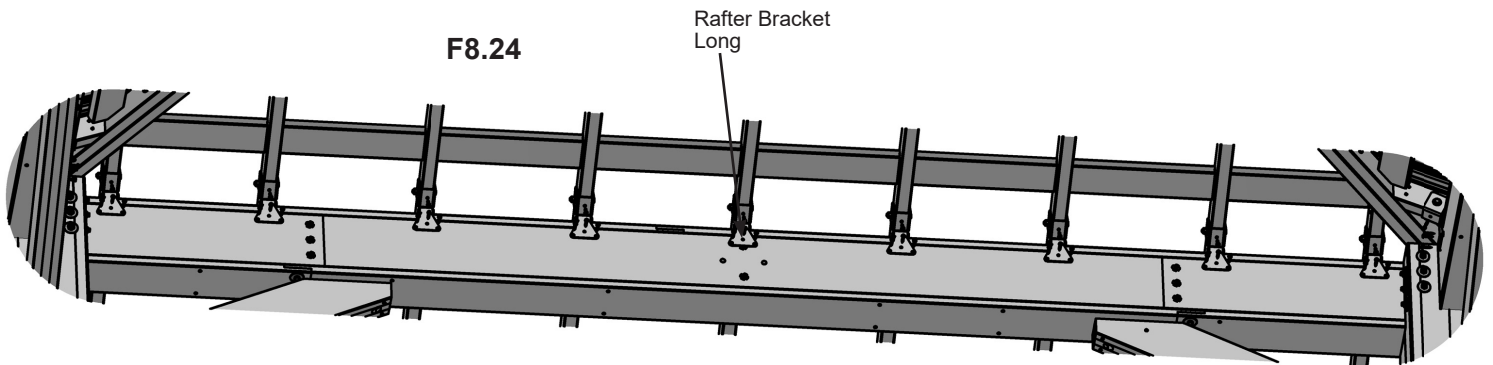

Hardware

144 x  #10 x 1-1/4" Pan Screw

Step 9: Attach Roof Peak Brackets



A: On the Roof Peak Brackets, tighten the two screws then attach the Corner Rafter Assemblies in the remaining holes using (14) S12. Tighten the WN1 Lock Wing Nut. (F9.1 and F9.2)

F9.1



F9.2

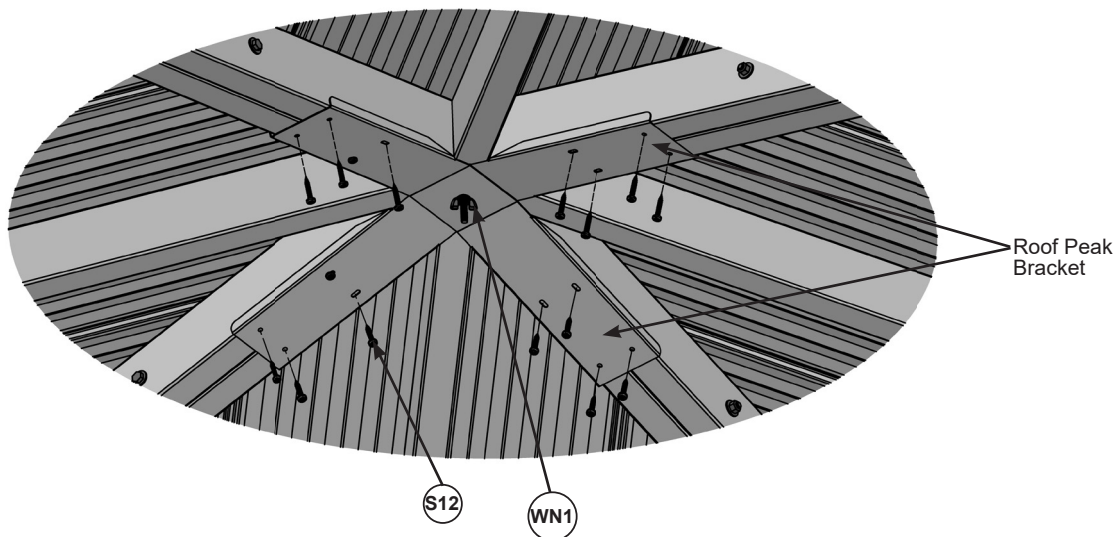

Hardware

14 x **S12** #10 x 1-1/4" Pan Screw

Step 10: Tighten Bolts in Corner Bracket Assembly



A: Tighten all bolts and lags in the Corner Bracket Assemblies in all 4 corners. (F10.1 and F10.2)

F10.1

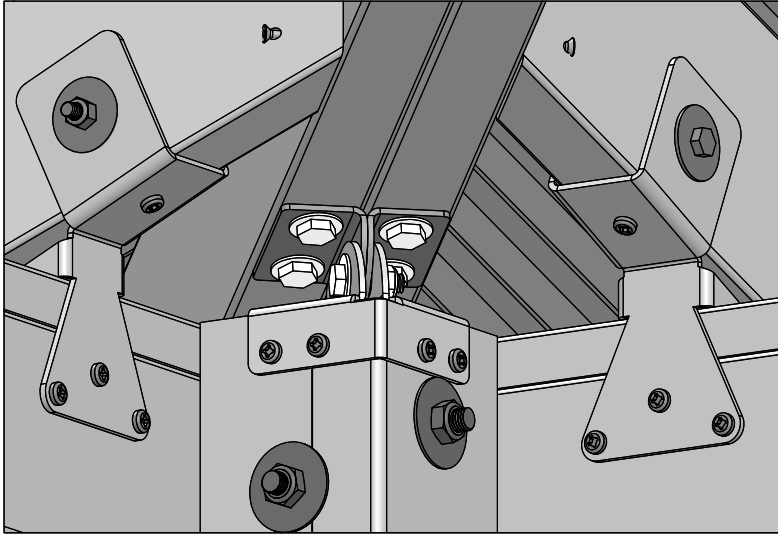

F10.2

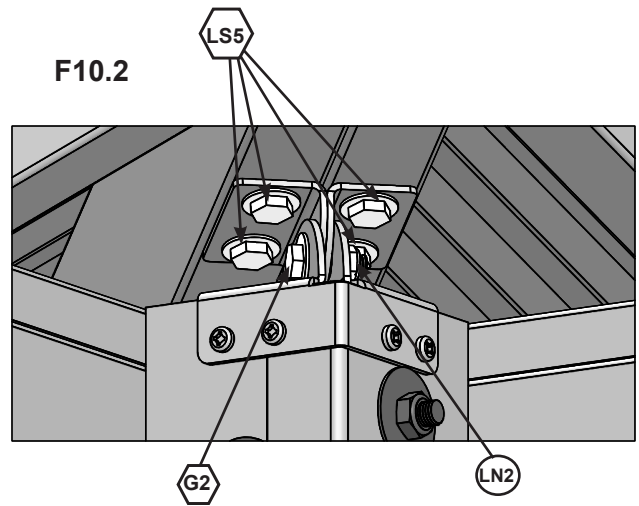

Step 11: Attach Corner Caps



A: Place one Corner Cap at each corner, push up to ensure the bottom is tight to the bottom of the fascia, then attach with four SM0 per Corner Cap. (F11.1 and F11.2)

F11.1

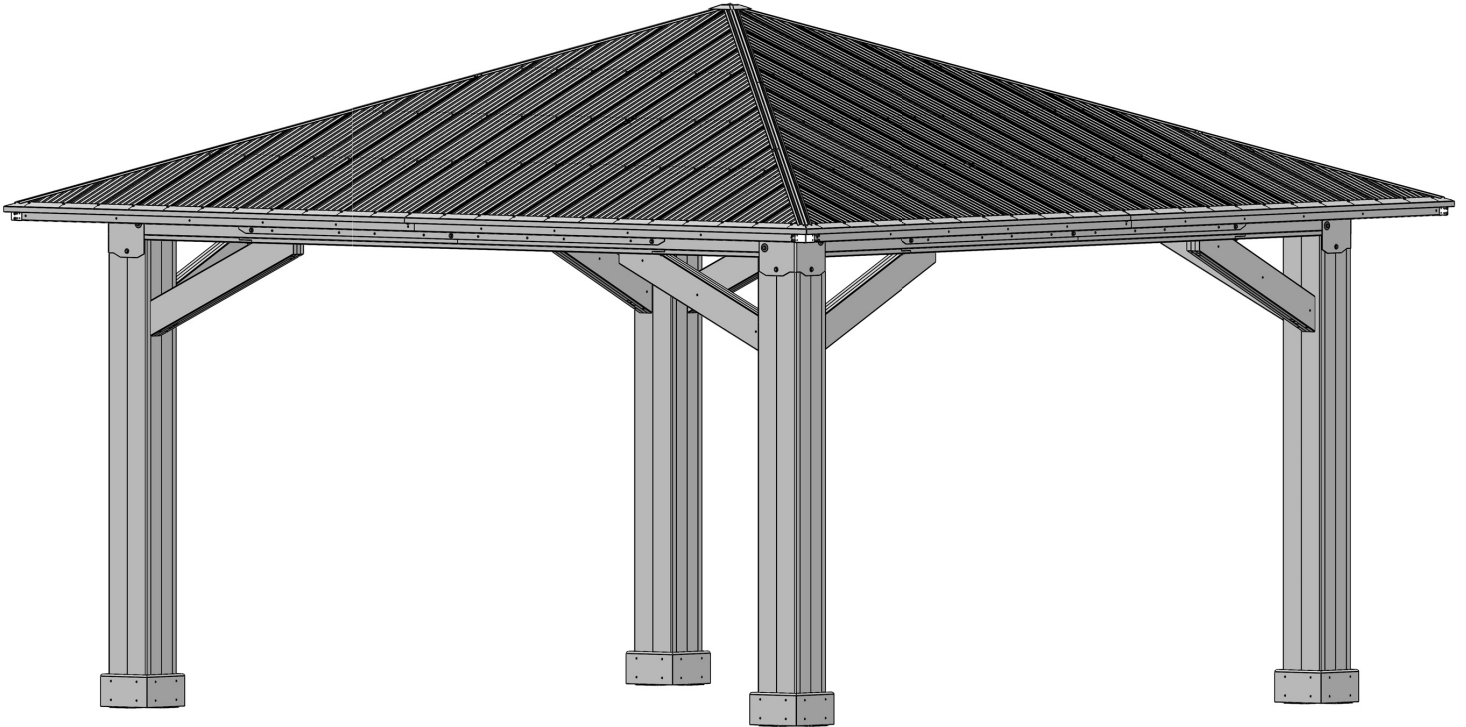

F11.2

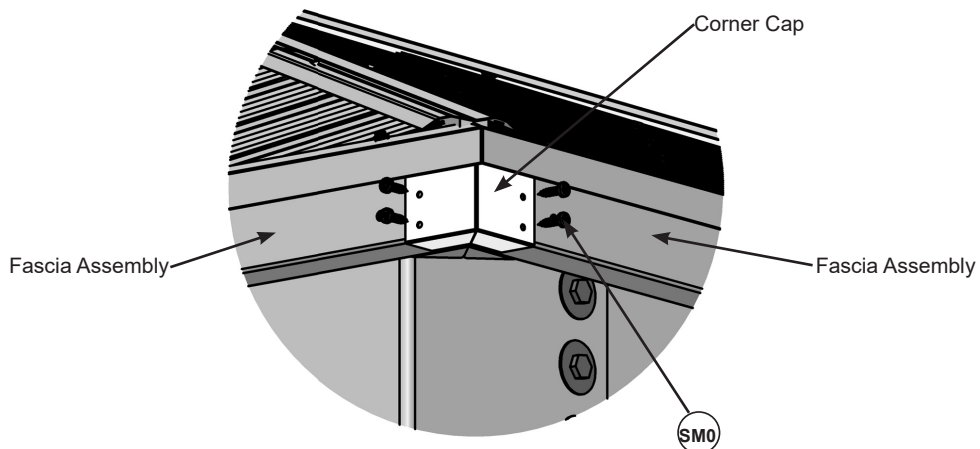

Components

4 x Corner Cap

Hardware

16 x **SM0** #8 x 3/4" Sheet Metal Screw

Step 12: Attach Ridge Caps



A: At each corner, slide one Ridge Cap Long over the Ridge Clips. Make sure to slide the cap from the bottom up, with the cut end leading. (F12.1 and F12.2)

B: Slide Ridge Cap Short over the Ridge Clips leading with the insert end to push the Ridge Cap Long to the top, lifting Peak Cap Assembly so Ridge Cap Long fits under. Attach with two SM0 per Ridge Cap set. (F12.1, F12.2, F12.3 and F12.4)

F12.1

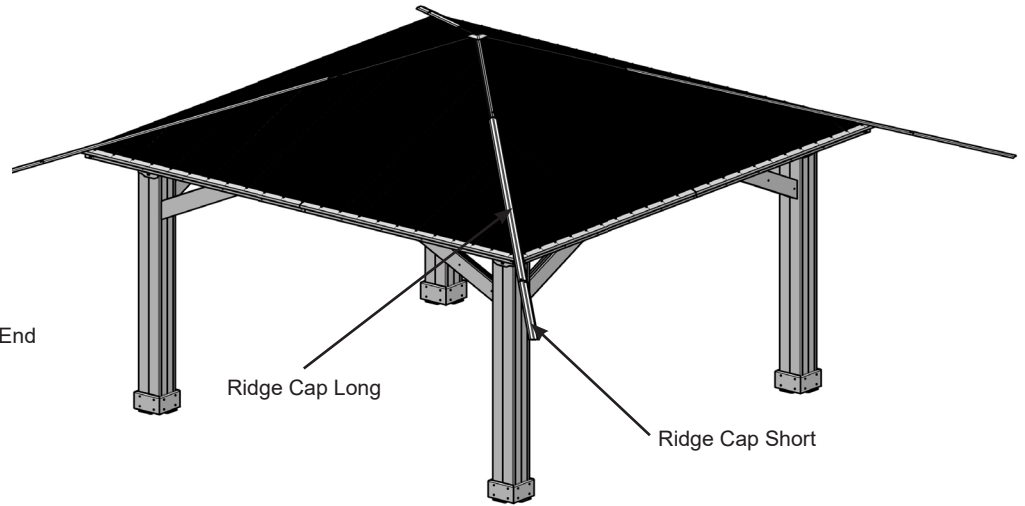

F12.3

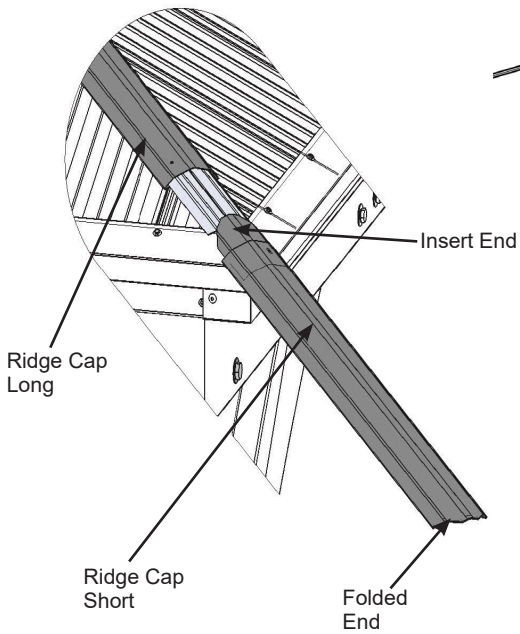

F12.2

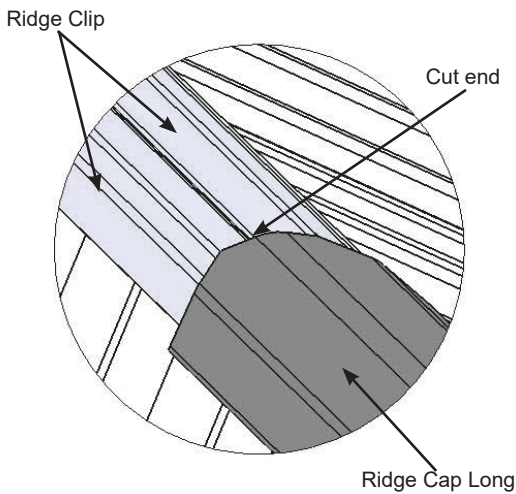

F12.4

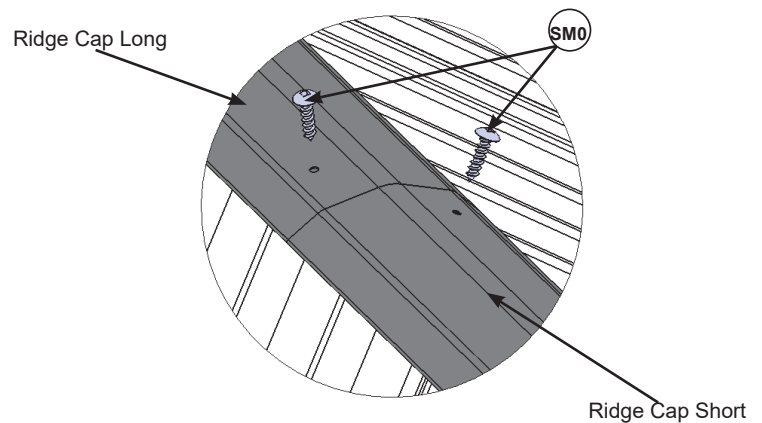

Components

- 4 x Ridge Cap Long
- 4 x Ridge Cap Short

Hardware

- 8 x **SM0** #8 x 3/4" Sheet Metal Screw

Step 13: Center Truss Assembly Part 1

A: Place two Horizontal Truss A's and two Horizontal Truss B's in the notch out of the Truss Bottom Bracket as shown in F13.1, F13.2 and F13.3.

Note bracket orientation on Horizontal Trusses

F13.1

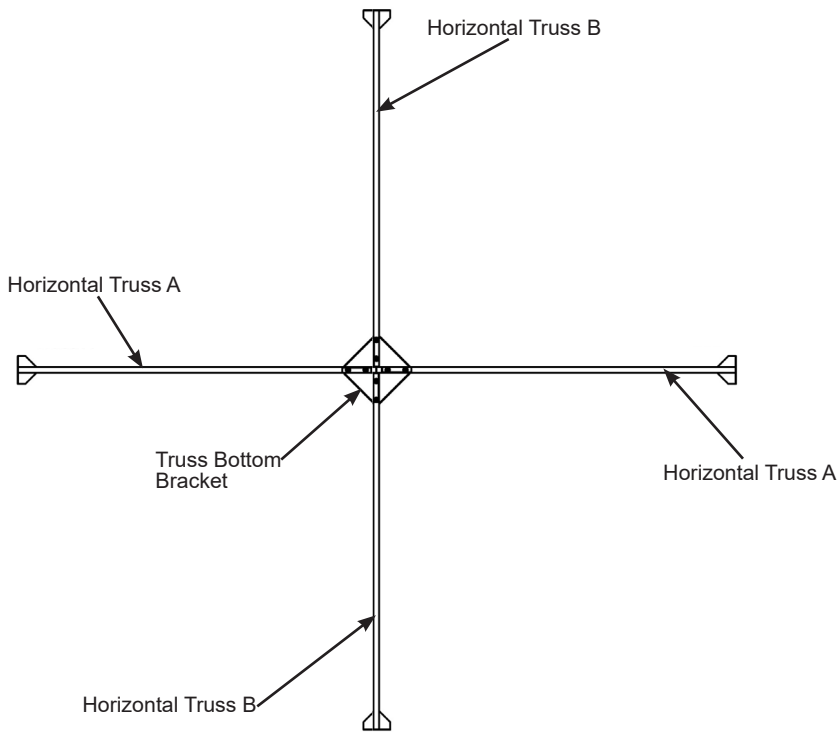

F13.2

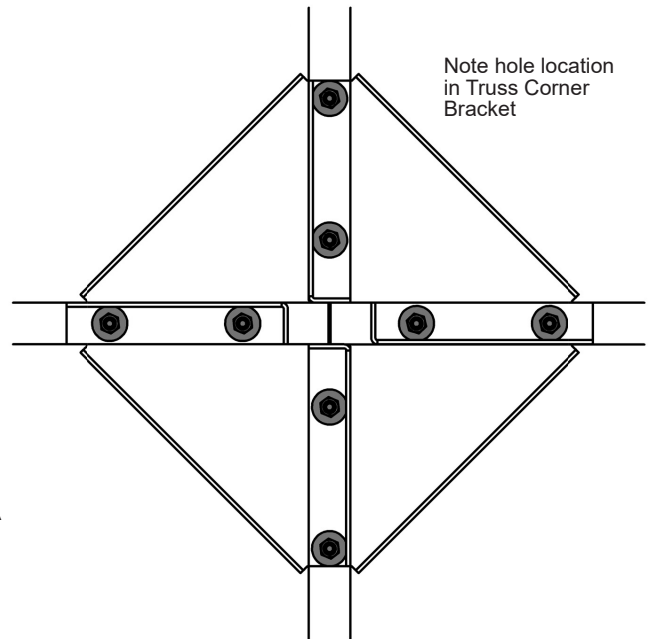

F13.3

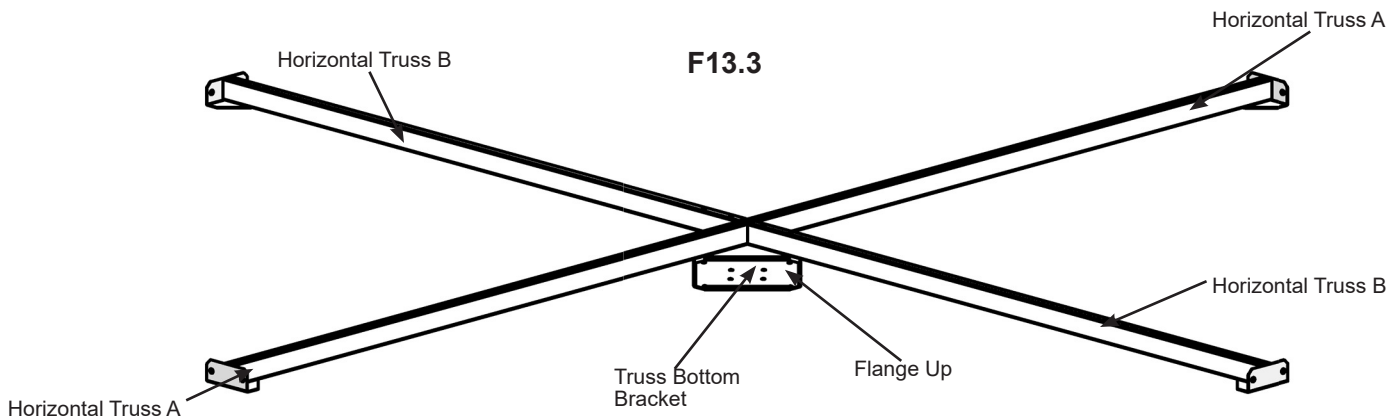

Components

- 1 x Truss Bottom Bracket
- 2 x Horizontal Truss A
- 2 x Horizontal Truss B

Step 13: Center Truss Assembly

Part 2

B: Take one Truss Corner Bracket and attach it loosely to each Horizontal Truss through the Truss Bottom Bracket using two G31 (with FW2 x 2 and LN2) per Truss Corner Bracket (F13.4 and F13.5)

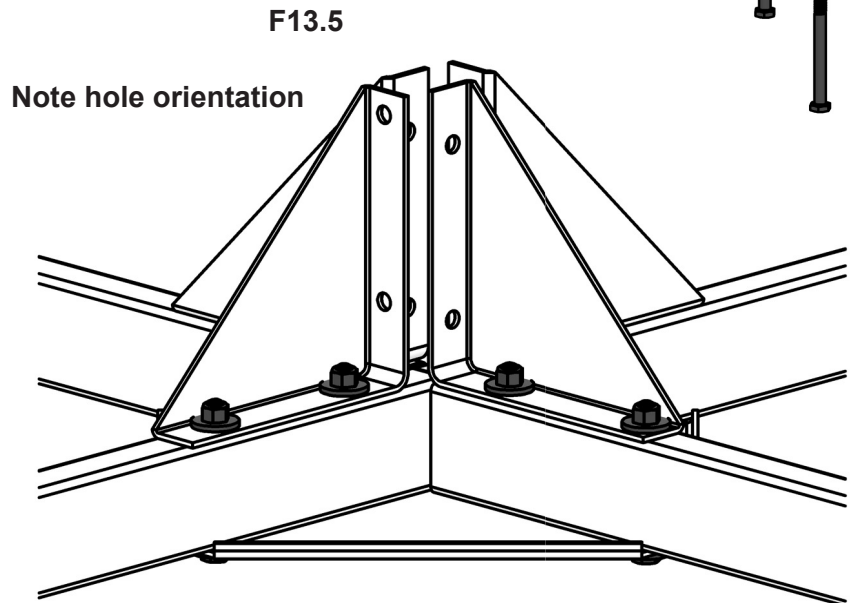
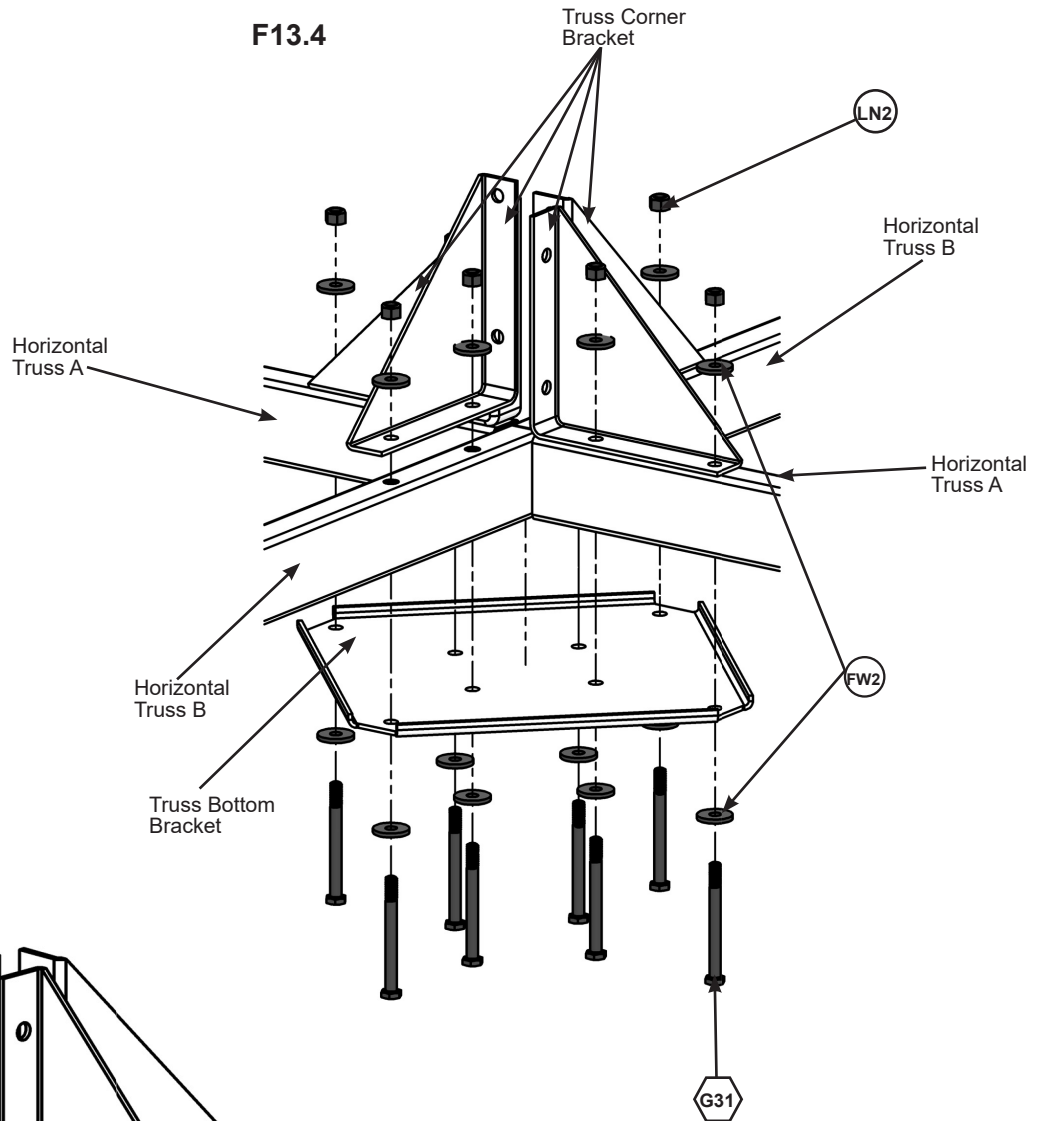

Components

4 x Truss Corner Bracket

Hardware

8 x  5/16 x 3-1/4" Hex Bolt

8 x  5/16" Lock Nut

16 x  5/16" Flat Washer

Step 13: Center Truss Assembly Part 3

C: Place Truss Tie Vertical inside Truss Corner Brackets so holes are aligned. Attach Truss Vertical Tie to Truss Corner Brackets using two G31 (with FW2 x 2 and LN2) and two G8 (with FW2 x 2 and LN2). (F13.6 and F13.7)



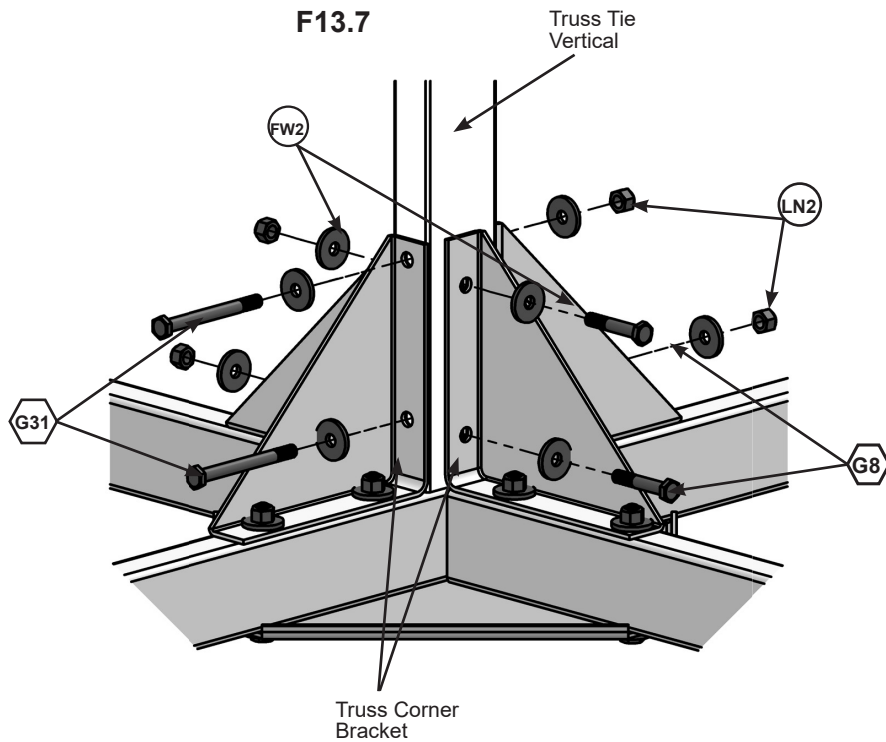
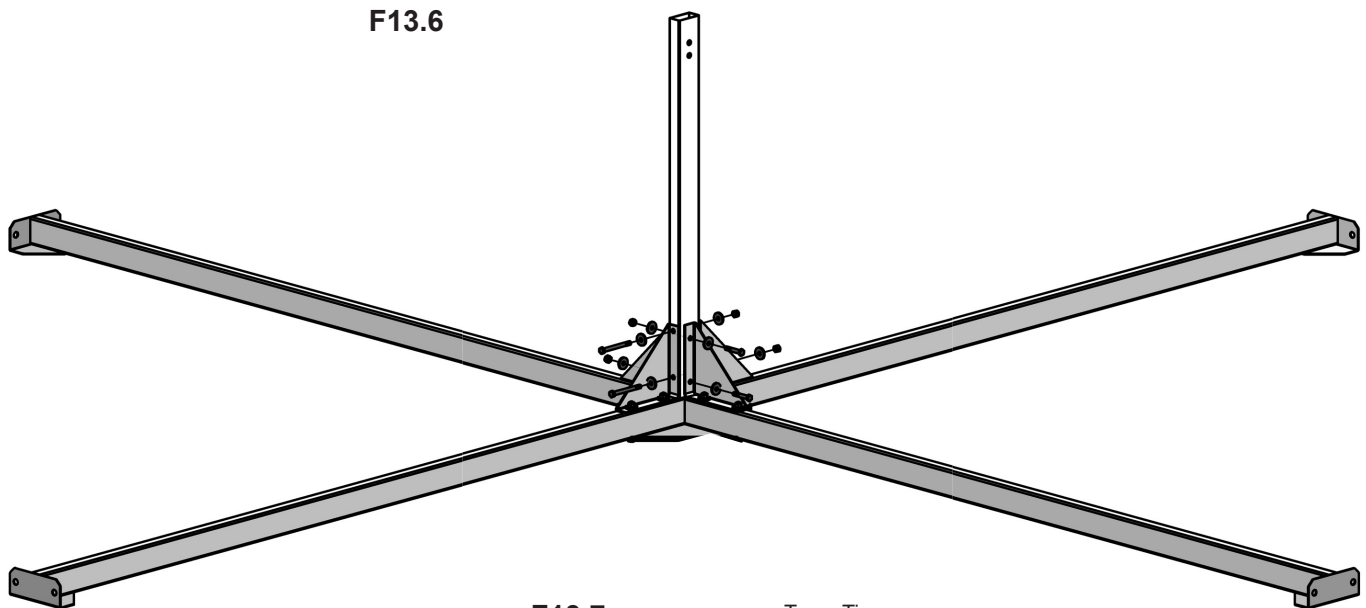

D: Tighten all bolts.



Components

1 x Truss Tie Vertical

Hardware

2 x  5/16 x 3-1/4" Hex Bolt	2 x  5/16 x 2" Hex Bolt
8 x  5/16" Flat Washer	4 x  5/16" Lock Nut

Step 13: Center Truss Assembly Part 4

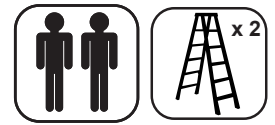

E: Using two G24 (with FW2 x 2 and LN2) connect Center Truss Assembly to each Beam Assembly at the center. (F13.8, F13.9 and F13.10)

F: Attach one Truss Rafter Tie on each side of Truss Tie Vertical using two G37 (with FW2 x 2 and LN2). (F13.8 and F13.10)

G: Attach Truss Rafter Tie to (2581) using four S12 per bracket. (F13.8 and F13.10)

F13.8

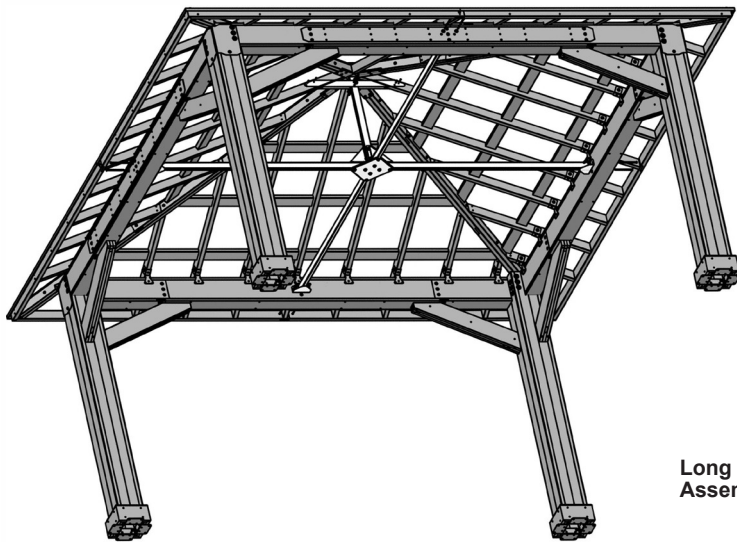

F13.9

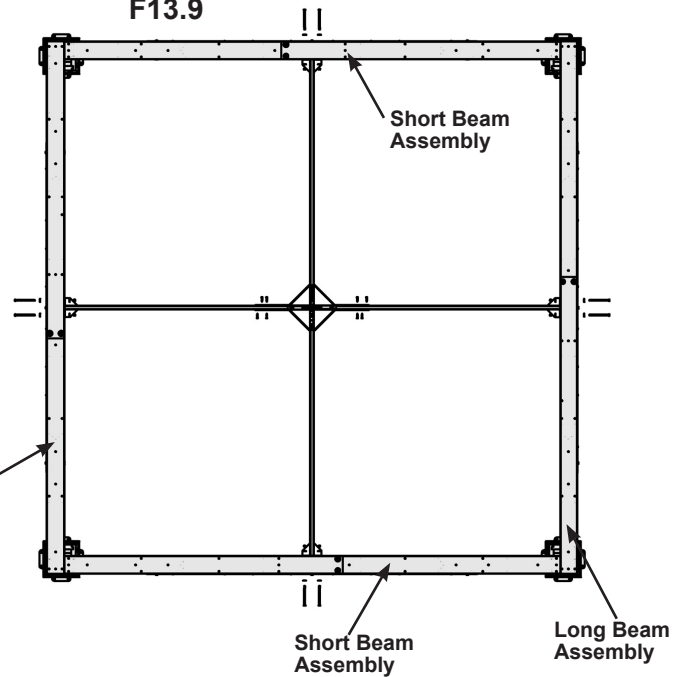

F13.10

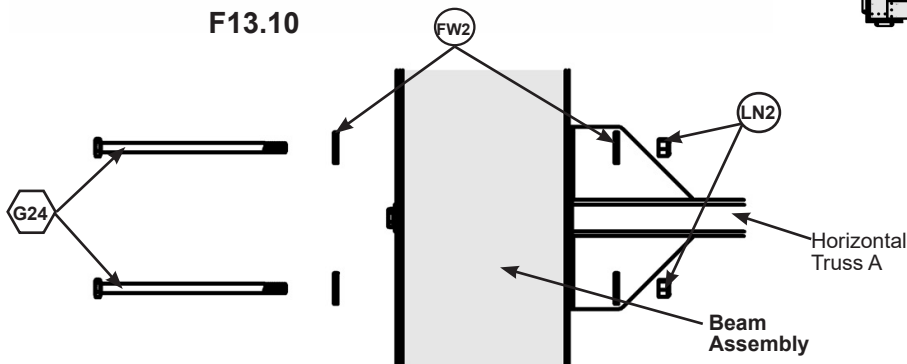

F13.11

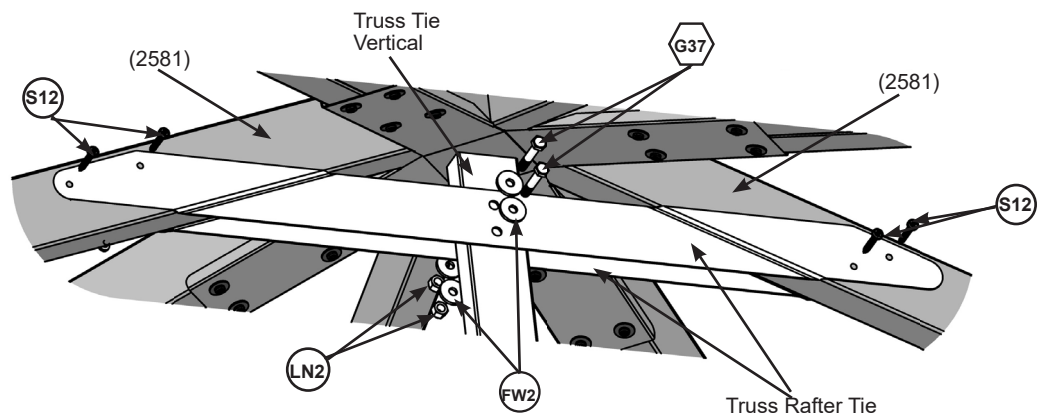

Components

2 x Truss Rafter Tie

Hardware

8 x G24	5/16 x 6-1/4" Hex Bolt	2 x G37	5/16 x 1-3/4" Hex Bolt
10 x S12	#10 x 1-1/4" Pan Screw	10 x LN2	5/16" Lock Nut
		20 x FW2	5/16" Flat Washer

Step 14: Attach Plaque and Hooks



A: Attach Gazebo ID Plaque to a prominent location on your Gazebo with two S10. This provides warnings concerning safety and important contact information. (F14.1 and F14.2)

B: Two 50 mm Hooks are included with this unit for attaching wiring. They can be placed anywhere along the Rafters as needed. Pre-drill with a 1/8" drill bit before installing. (F14.3 and F14.4)

F14.1

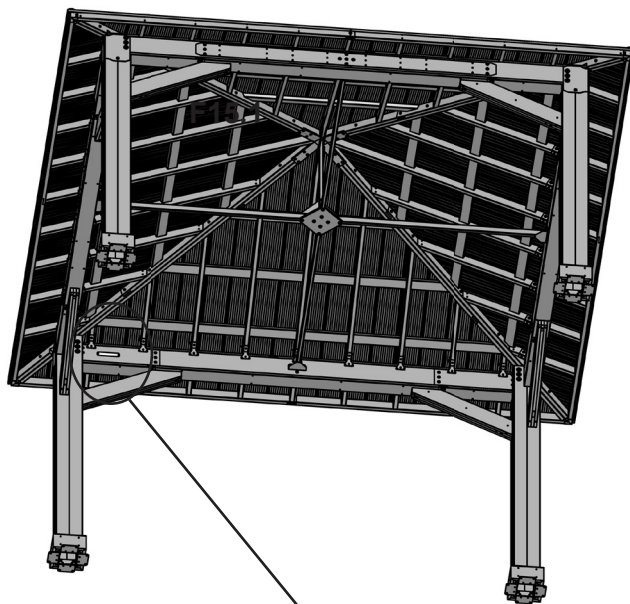

F14.4

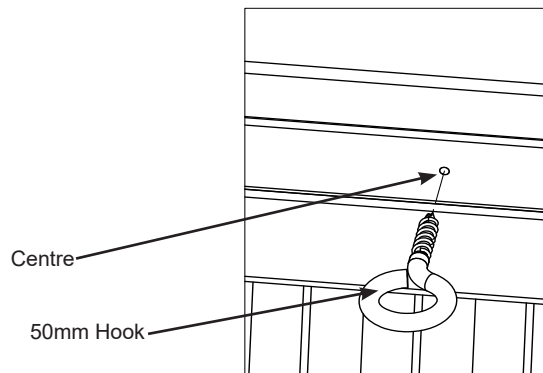

F14.3

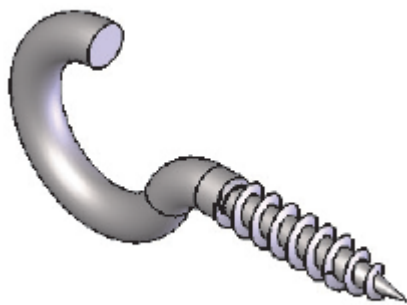

F14.2

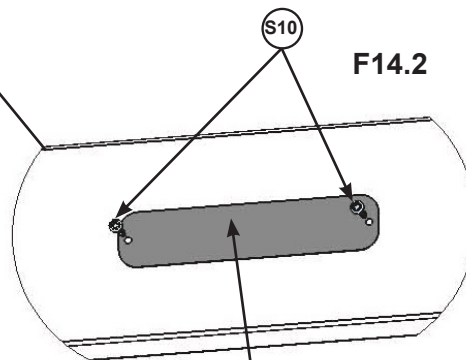

Note: We have provided two 50 mm hooks for optional use to hold in place any wires if required. These hooks are not designed to hold any heavy products such as lights, flower pots, etc.

Components

1 x Gazebo ID Plaque
2 x 50mm Hook

Hardware

2 x S10 #8 x 1" Pan Screw



Yardistry® 375 Sligo Road West, P.O. Box 10, Mount Forest, ON Canada N0G 2L1

Distributed by:
Costco Wholesale Corporation
P.O. Box 34535
Seattle, WA 98124-1535
USA
1-800-774-2678
www.costco.com

Costco Wholesale Canada Ltd.*
415 W. Hunt Club Road
Ottawa, Ontario
K2E 1C5, Canada
1-800-463-3783
www.costco.ca
* faisant affaire au Québec sous
le nom les Entrepôts Costco

Importado por:
Importadora Primex S.A. de C.V.
Blvd. Magnocentro No. 4
San Fernando La Herradura
Huixquilucan, Estado de México
C.P. 52765
RFC: IPR-930907-S70
(55)-5246-5500
www.costco.com.mx

Costco Wholesale Australia Pty Ltd
17-21 Parramatta Road
Lidcombe NSW 2141
Australia
www.costco.com.au

Costco Wholesale UK Ltd /
Costco Online UK Ltd
Hartspring Lane
Watford, Herts
WD25 8JS
United Kingdom
01923 213113
www.costco.co.uk

Costco Wholesale Spain S.L.U.
Polígono Empresarial Los Gavilanes
C/ Agustín de Betancourt, 17
28906 Getafe (Madrid) España
NIF: B86509460
900 111 155
www.costco.es

Costco Wholesale Iceland ehf.
Kauptún 3-7, 210 Gardabaer
Iceland
www.costco.is

Costco France
1 avenue de Bréhat
91140 Villebon-sur-Yvette
France
01 80 45 01 10
www.costco.fr

Costco Wholesale Japan Ltd.
2 Kakuchi, 2 Gaiku, Kaneda-Nishi
361 Urakura, Kisarazu shi
Chiba, 292-0007 Japan
0570-200-800
www.costco.co.jp

Costco Wholesale Korea, Ltd.
40, Iljik-ro
Gwangmyeong-si
Gyeonggi-do, 14347, Korea
1899-9900
www.costco.co.kr

Costco Wholesale New Zealand Limited
2 Gunton Drive
Westgate
Auckland 0814
New Zealand
www.costco.co.nz

Costco (China) Investment Co., Ltd.
Room 01 Mezzanine
No. 5178, Kang Xin Highway
Pudong New District
Shanghai
China 201315
+86-21-6257-7065

Costco Wholesale Sweden AB
Box 614
114 11 Stockholm
Sweden
www.costco.se

MADE IN CHINA / FABRIQUÉ EN CHINE / HECHO EN CHINA



Customer Registration Card - Carte d'inscription du client - Tarjeta de Registro del Cliente

First Name - Prénom - Primer Nombre	Initial - Initiale - Inicial	Last Name - Nom de famille - Apellido

Street - Rue - Calle	PO Box - Boîte postale - Casilla postal	Apt. No. - App.

City - Ville - Ciudad	State/Province - État/Province - Estado/Provincia

ZIP/Postal Code - ZIP/Code postal - Código Postal	Country - Pays - País

E-mail Address - Adresse courriel - Dirección de E-mail	Telephone Number - N° de téléphone - No. de Teléfono

Model Name - Nom du modèle - Nombre del Modelo	Model Number (from front cover) - N° du modèle (page de couverture) - Número de Modelo (de la portada)

Date of Purchase - Date d'achat - Fecha de Compra (mm/dd/yyyy) (mm/jj/aaaa) (mm/dd/aaaa)	Place of Purchase - Lieu d'achat - Comprado a

Comments - Commentaires - Comentarios :

Mail To - Envoyer par courrier à - Enviar por Correo a:

Yardistry
375 Sligo Road West, PO Box 10
Mount Forest, Ontario, Canada, N0G 2L0
Attention: Consumer Relations
À l'attention de : Service à la clientèle
Atención a: Servicio de Atención al Cliente

Online Registration - Enregistrement en ligne - Registro online:

www.yardistrystructures.com/warranty

1.888.509.4382

Hours/ Heures/ Horas: 8:30 am - 5:00 pm EST
(excl. holidays/ hors jours fériés/ excepto los días festivos)

Teléfono no Válido en México

English and French Spoken / Anglais et français parlés / Inglés y francés hablado

Yardistry would like to say "Thank you" for your time and feedback.

Yardistry aimerait vous remercier d'avoir pris le temps de répondre au sondage.

Yardistry quiere "Agradecerle" por su tiempo y su opinión.