

# 3.7 m (12.1 ft) x 4.3 m (14.1 ft) YARDISTRY GAZEBO

## Installation and Operating Instructions – YM12983X

ITM. / ART. 1713420



IMPORTANT, RETAIN FOR FUTURE REFERENCE: READ CAREFULLY  
THIS ITEM IS INTENDED FOR OUTDOOR DOMESTIC USE ONLY.  
NOT FOR COMMERCIAL USE.

Revised 03-11-2026

# YARDISTRY®

Yardistry – North America  
Toll Free Customer Support:  
1.888.509.4382

Mon - Fri, 8:30 am - 5:00 pm EST  
(excl. holidays)

English and French Spoken

For extended hours see our website:

[www.yardistrystructures.com](http://www.yardistrystructures.com)  
[info@yardistrystructures.com](mailto:info@yardistrystructures.com)

Patents Pending

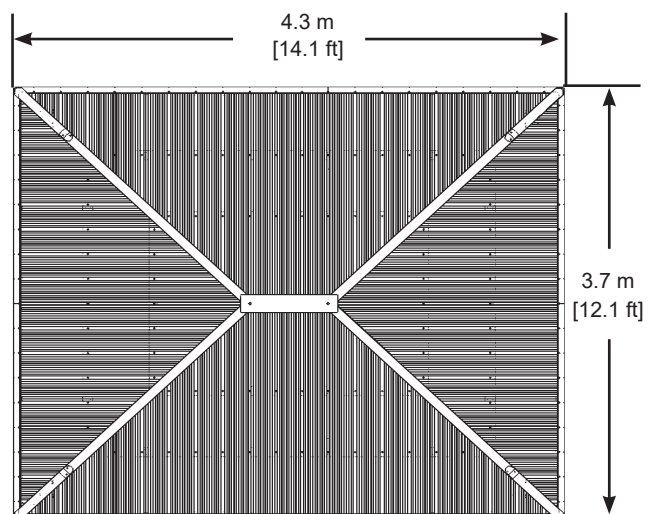

HEIGHT: 3.1 m / 10.1 ft

## **Important Safety Notice!**

Yardistry components are intended for privacy, decorative and ornamental use only.

### **Product is NOT INTENDED for the following:**

- A safety barrier to prevent unsupervised access to pools, hot tubs, spas or ponds.
- As load bearing support for a building, structure, heavy objects or swings.
- Used in structures that trap wind, rain or snow that would create extra load on the product.

### **Accumulated snow must be removed from roof.**

**DO NOT** climb or walk on roof for any reason.

**Permanent structures may require a building permit.** As the purchaser and/or installer of this product you are advised to consult local planning, zoning and building inspection departments for guidance on applicable building codes and/or zoning requirements.

**Wood is NOT flame retardant and will burn.** Grills, fire pits and chimineas are a fire hazard if placed too close to a Yardistry structure. Consult user's manual of the grill, fire pit or chiminea for safe distances from combustible materials.

**Wear gloves to avoid injury** from possible sharp edges of individual elements before assembly.

**During installation, follow all safety warnings provided with your tools and use OSHA approved safety glasses.** Some structures may require two or more people to install safely.

**Check for underground utilities before digging or driving stakes into the ground!**

**During assembly it is important to closely follow the instructions.** Complete the assembly on a solid, level surface and follow the instructions to square up, level and anchor the structure. This will reduce the gaps at wood connections during assembly.

## **General Information**

**General Information:** Wood components are manufactured with premium outdoor lumber (*C. lanceolata*) which is protected with factory applied water-based stain. Knots, small checks (cracks) and weathering are naturally occurring and do not affect the strength of the product. Annual application of a water-based water repellent sealant or stain is important and will help reduce weathering and checks.

**[www.yardistrystructures.com](http://www.yardistrystructures.com)**

Questions?

Call toll free or write us at:

1 (888) 509-4382

[support@yardistrystructures.com](mailto:support@yardistrystructures.com)

Regular Hours: Mon - Fri, 8:30 am - 5:00 pm EST  
(excl. holidays)

English and French Spoken

(For extended hours see our website)

[www.yardistrystructures.com](http://www.yardistrystructures.com)

Patents Pending

# Limited Warranty

Yardistry warrants that this product is free from defect in materials and workmanship for a period of one (1) year from the original date of purchase. In addition, for any product with lumber, all lumber is warranted for five (5) years against rot and decay. This warranty applies to the original owner and registrant and is non-transferable.

Regular maintenance is required to assure the integrity of your product and is a requirement of the warranty. This warranty does not cover any inspection costs.

## **This Limited Warranty does not cover:**

- Labor for replacement of any defective item(s);
- Incidental or consequential damages;
- Cosmetic defects which do not affect performance or integrity;
- Vandalism; improper use or installation; acts of nature, including but not limited to wind, storms, hail, floods, excessive water exposure;
- Minor twisting, warping, checking or any other natural occurring properties of wood that do not affect performance or integrity.

Yardistry products have been designed for safety and quality. Any modifications made to the original product could damage the structural integrity of the product leading to failure and possible injury. Yardistry cannot assume any responsibility for modified products. Furthermore, modification voids any and all warranties.

**This product is warranted for RESIDENTIAL USE ONLY. Yardistry disclaims all other representations and warranties of any kind, express or implied.**

*This Warranty gives you specific legal rights. You may have other rights as well which vary from state to state or province to province. This warranty excludes all consequential damages, however, some states/provinces do not allow the limitation or exclusion of consequential damages, and therefore this limitation may not apply to you.*

AUSTRALIA: Our goods come with guarantees that cannot be excluded under the Australian Consumer Law. You are entitled to a replacement or refund for a major failure and for compensation for any other reasonably foreseeable loss or damage. You are also entitled to have the goods repaired or replaced if the goods fail to be of acceptable quality and the failure does not amount to a major failure.

# Instructions for Proper Maintenance

Your Yardistry structure is designed and constructed of quality materials. As with all outdoor products it will weather and wear. To maximize the enjoyment, safety and life of your structure it is important that you, the owner, properly maintain it.

## HARDWARE:

- Check metal parts for rust. If found, sand and repaint using a non-lead paint complying with 16 CFR 1303.
- Inspect and tighten all hardware after completion of assembly; after first month of use; and then annually. Do not over-tighten as to cause crushing and splintering of wood.
- Check for sharp edges or protruding screw threads, add washers if required.

## WOOD PARTS:

- Applying a water repellent or stain (water-based) on a yearly basis is important maintenance to maintain maximum life and performance of the product.
- Check all wood members for deterioration, structural damage and splintering. Sand down splinters and replace deteriorated wood members. As with all wood, some checking and small cracks in grain is normal.
- Some gapping may occur at some wood connections.

## Assembly Guides

### Tools Required (not included):

- |                              |                    |                              |
|------------------------------|--------------------|------------------------------|
| • Tape Measure               | • 8 ft Step Ladder | • 6 ft Step Ladder x 2       |
| • Carpenters Level           | • Safety Glasses   | • Square                     |
| • Standard or Cordless Drill | • Adult Helper     | • Ratchet                    |
| • Claw Hammer                | • Safety Gloves    | • 7/16", 1/2" & 9/16" Socket |
| • 7/16", 1/2" & 9/16" Wrench | • Hard Hat         |                              |

### Symbols:

Throughout these instructions symbols are provided in the top, right-hand corner of the page.



- Use Help, where this is shown, 2, 3 or 4 people are required to safely complete this step. To avoid injury or damage to the assembly make sure to get some help.



- Use a measuring tape to assure proper location



- Pre-drill a pilot hole before fastening screw or lag to prevent splitting of wood.

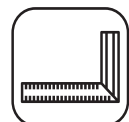

- Check that assembly is square before tightening bolts



- Check that the assembly is level



- One or more ladders are required to safely complete this step.

**If you dispose of your Yardistry structure:** Please disassemble and dispose of your unit so that it does not create any unreasonable hazards at the time it is discarded. Be sure to follow your local waste ordinances.

## Assembly Tips

Following are some helpful tips to make the assembly process smooth and efficient.

### PRE-ASSEMBLIES:

(i.e. Post and Beam Assemblies, Roof Rafter Assembly, etc)

- Work on a raised, solid and flat surface such as a table or saw horse.
- Keep all connections flush where shown in the instructions.
- When assembling the beams keep parts flat, straight and snug when connecting.

### METAL PARTS:

- Roofing material may have sharp edges, wear safety gloves.
- Remove all plastic covering, on both sides of the metal panels, directly before installing each piece.
- If film is difficult to remove, spray a mixture of dish soap and water continuously between the film and the panel and peel back slowly.
- Place roofing material on a non-abrasive surface before and after assembly as it can bend, dent and scratch easily.
- The roofing screws can easily crush the roof panels and roof edges when using a power drill. We recommend hand tightening the roofing screws so they sit snug and tight to the roofing material.

# Permanent Installation Examples

**Note: It is critically important you start with square, solid and level footings, concrete pad or deck to attach your Gazebo.**

We supply Post Mounts with this structure which gives you the flexibility to permanently install your structure to a pre-existing or new wood or concrete surface.

- The hardware to attach the Post Mount to the structure is included.
- The hardware to mount the structure permanently will need to be purchased separately at your local hardware store.

If you are mounting to concrete footers see below for the correct locations and placement. Please double check for possibility of any underground utilities such as gas, telephone, cable or sprinkler lines.

Following are some examples of how to mount the structure to wood or concrete surfaces.

Refer to your local building and city codes, ordinances, neighborhood covenants, or height restrictions regarding this type of structure for guidance on acceptable installation requirements.

## Concrete Footer

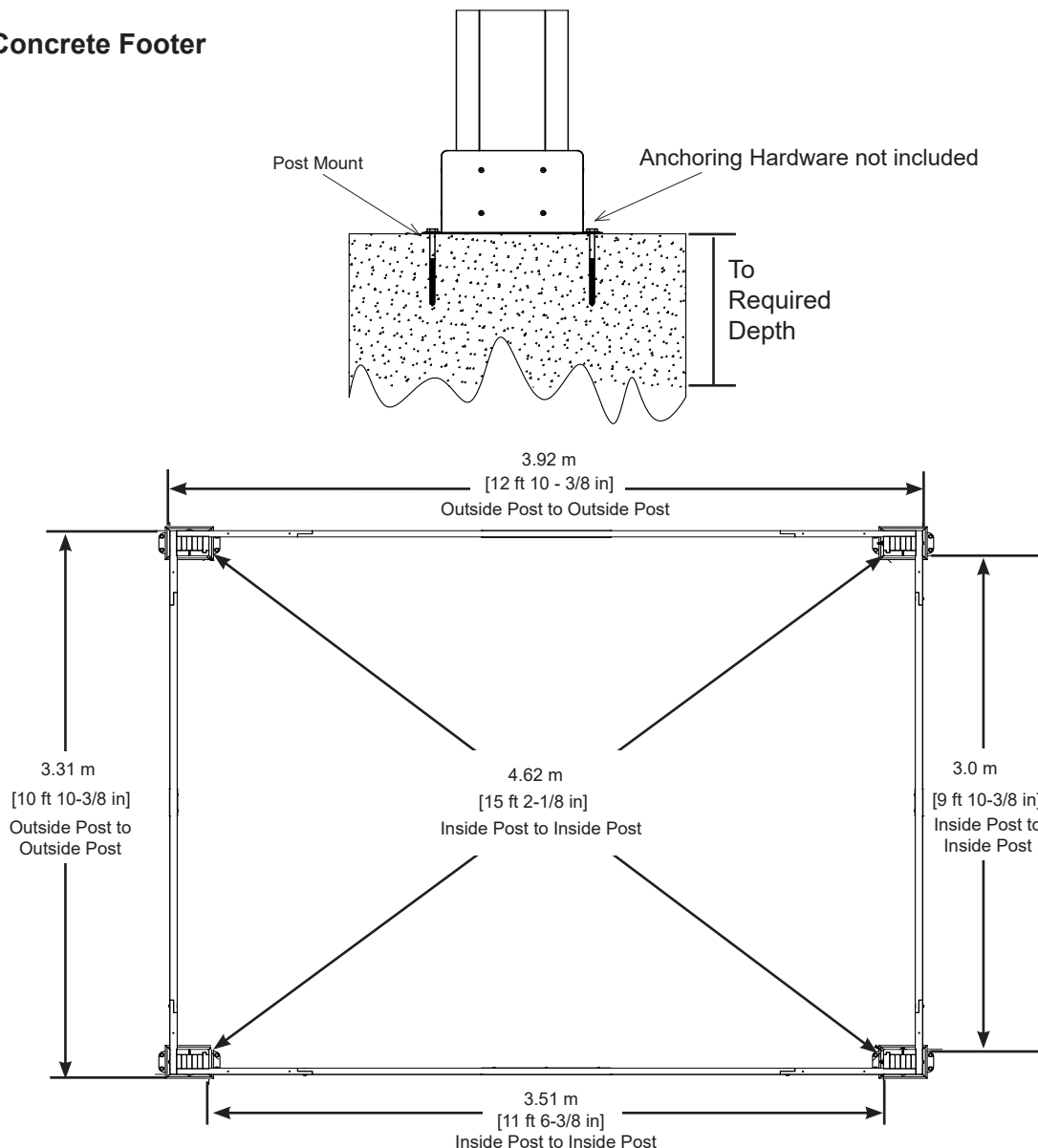

# Permanent Installation Examples cont.

**Concrete Patio [min. 3.61 m x 4.22 m (11 ft 10-3/8 in x 13 ft 10-3/8 in)]  
with 15.24 cm (6 in) clearance on all sides**

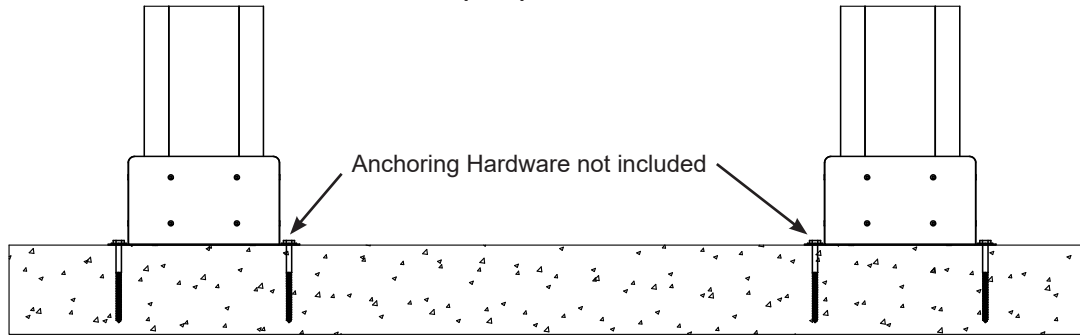

**Wood Deck [min. 3.61 m x 4.22 m (11 ft 10-3/8 in x 13 ft 10-3/8 in)]  
with 15.24 cm (6 in) clearance on all sides**

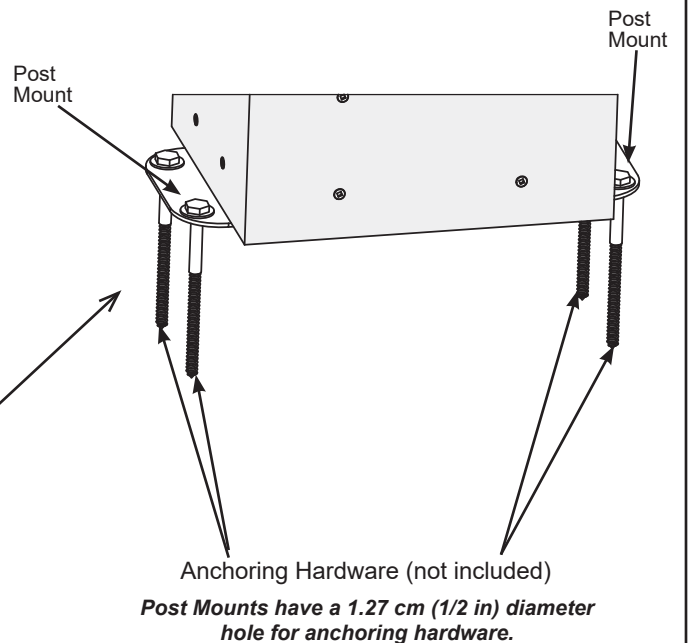
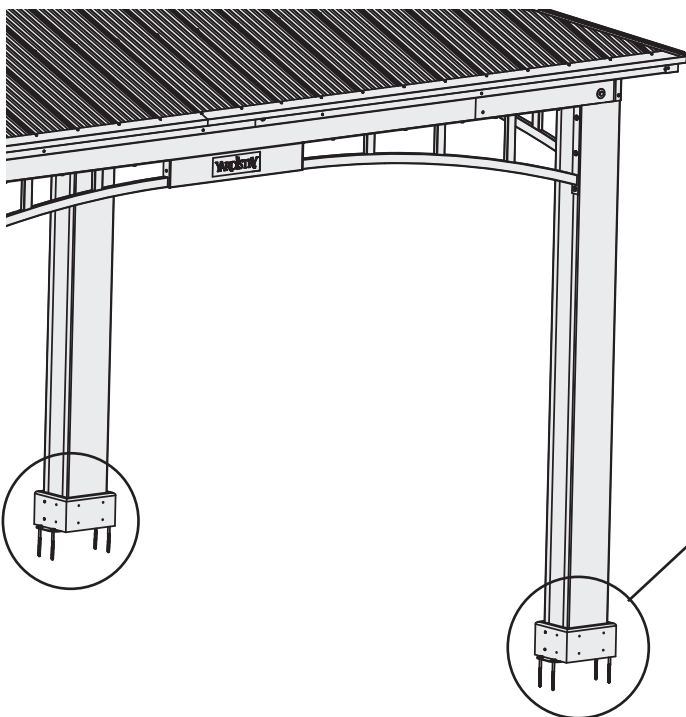
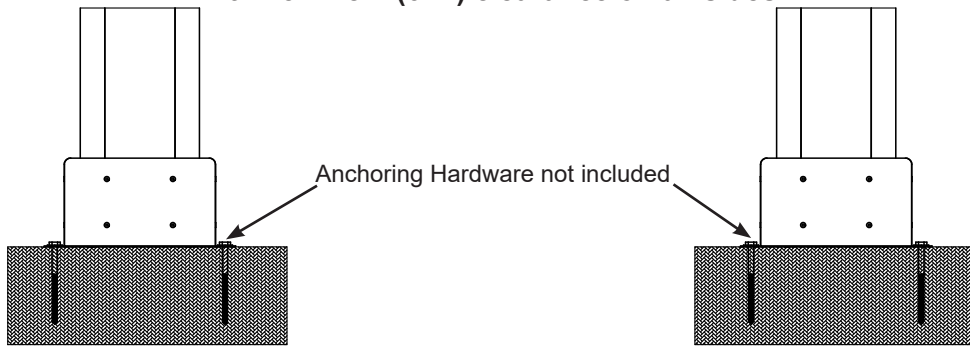

# Part Identification ( Dimensions are approximate and are shown to assist in the identification of parts for assembly. Actual dimensions may be smaller or larger. )

**2pc. (1916) - 6 x 8 Post Right Side 2387.6 mm (94") FSC**



**2pc. (1915) - 6 x 8 Post Left Side 2387.6 mm (94") FSC**



**2pc. (1914) - Beam Center Long 2590.8 mm (102") FSC**

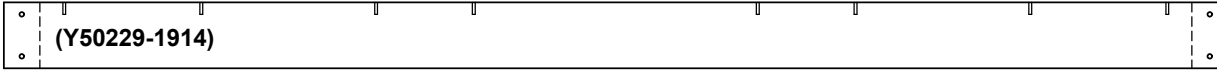

**4pc. (1912) - Beam End Long 706.5 mm (27 13/16") FSC**

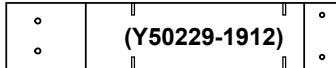

**2pc. (1913) - Beam Center Short 2558.6 mm (100 3/4") FSC**



**4pc. (1911) - Beam End Short 452.8 mm (17 13/16") FSC**

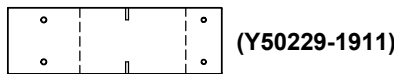

**2pc. (434) - Top 577.9 mm (22 3/4") FSC**

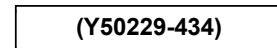

**2pc. (443) - Fascia Left 1853 mm (72 -15/16") FSC**

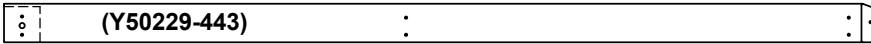

**8pc. (1048) - Plinth Long 250.8 mm (9 7/8") FSC**

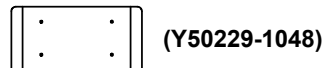

**8pc. (459) - Plinth 200 mm (7 7/8") FSC**

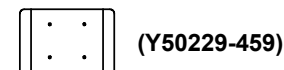

**2pc. (444) - Fascia Right 1853 mm (72 -15/16") FSC**

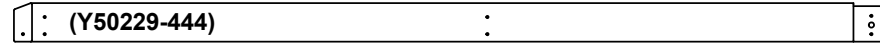

**2pc. (435) - Fascia Left - Large Roof 2157.7 mm (84 -15/16") FSC**

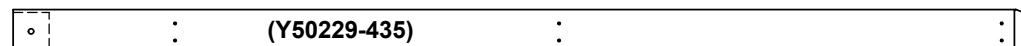

**2pc. (436) - Fascia Right - Large Roof 2157.7 mm (84 -15/16") FSC**

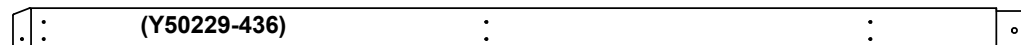

**6pc. (440) - Rafter 1915.4 mm (75 7/16") FSC**



**4pc. (2343) - Rafter Corner Right 2601.9 mm (102 7/16") FSC**

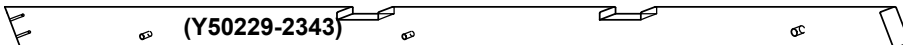

**4pc. (441) - Rafter Short Left 1040.2 mm (40 15/16") FSC**

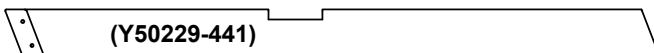

**4pc. (442) - Rafter Short Right 1040.2 mm (40 15/16") FSC**

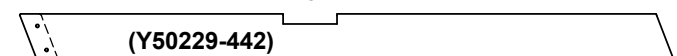

**4pc. (2342) - Rafter Corner Left 2601.9 mm (102 7/16") FSC**

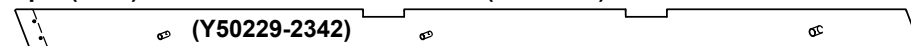

# Part Identification ( Dimensions are approximate and are shown to assist in the identification of parts for assembly. Actual dimensions may be smaller or larger. )

2pc. (337) - Strap Short 1561.3 mm (61 1/2") FSC

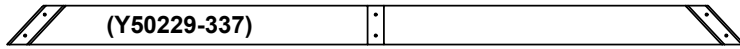

2pc. (433) - Strap Brace 574.7 mm (22 5/8") FSC



2pc. (430) - Strap Short - Large Roof 2170.9 mm (85 1/2") FSC

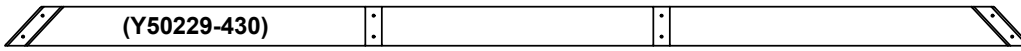

2pc. (437) - Strap 2603.5 mm (102 1/2") FSC

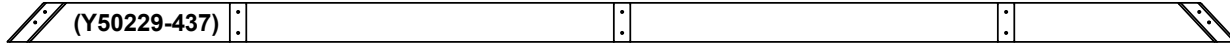

2pc. (432) - Strap Right - Large Roof 1605.6 mm (63 3/16") FSC

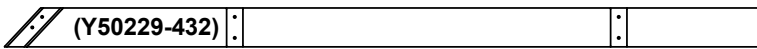

2pc. (431) - Strap Left - Large Roof 1605.6 mm (63 3/16") FSC

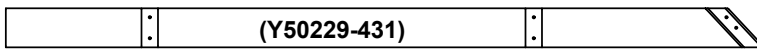

2pc. (461) - Tie 2336.8 mm (92") FSC

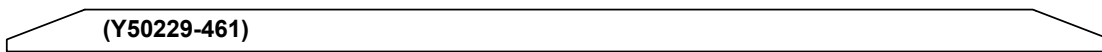

1pc. (463) - Spacer Top 574.7 mm (22 5/8") FSC

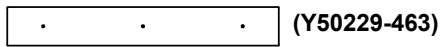

# Hardware Identification ( Dimensions are approximate and are shown to assist in the identification of parts for assembly. Actual dimensions may be smaller or larger. )

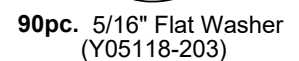
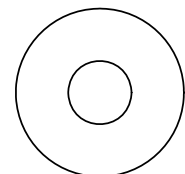
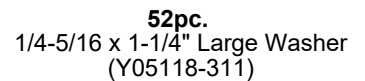
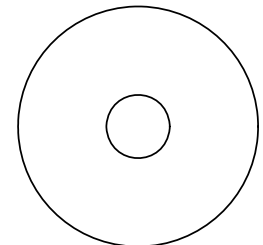
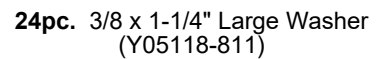
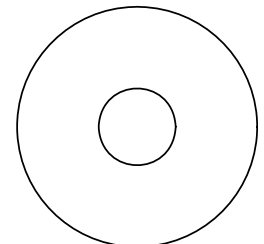
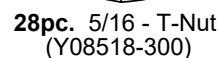
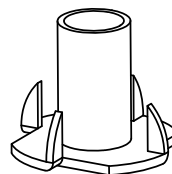
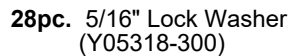
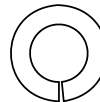
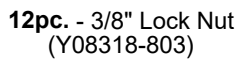
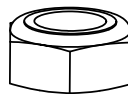
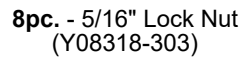
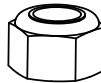
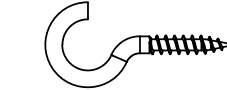
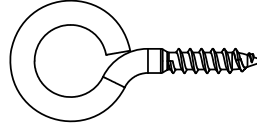
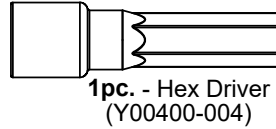
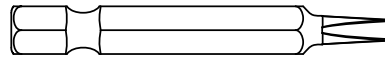
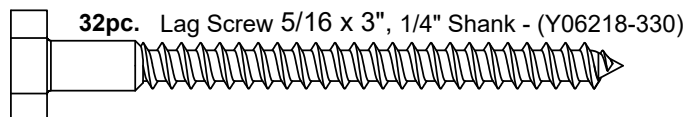
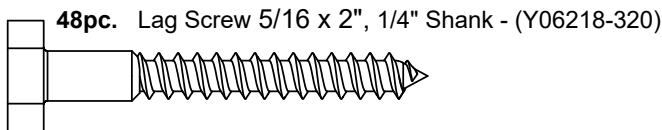
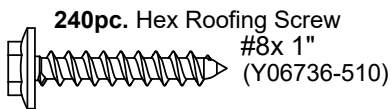
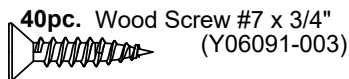
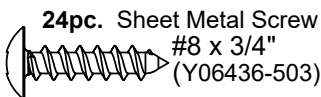
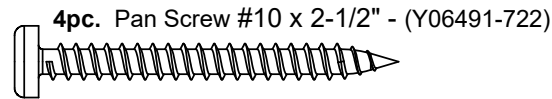
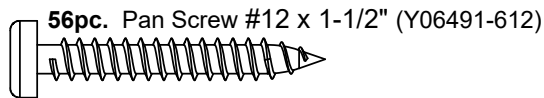
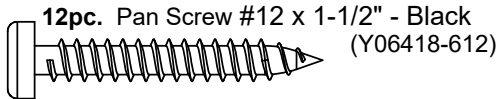
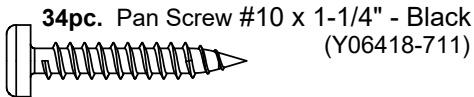
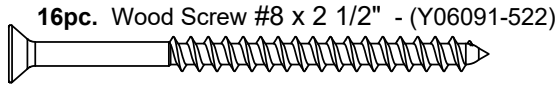
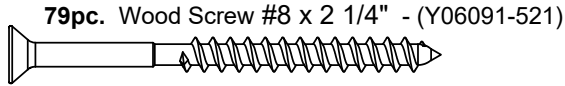
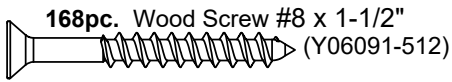

# Hardware Identification ( Dimensions are approximate and are shown to assist in the identification of parts for assembly. Actual dimensions may be smaller or larger. )

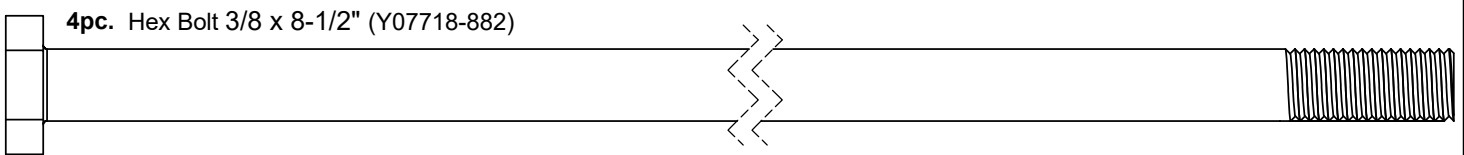
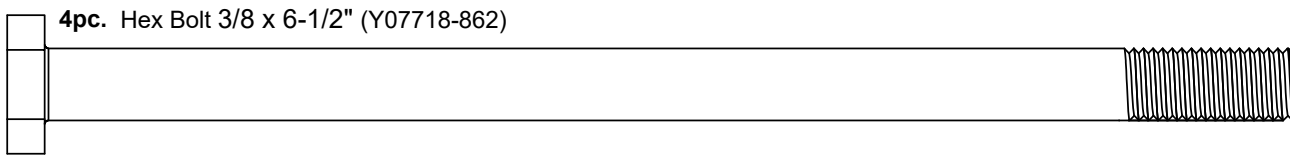
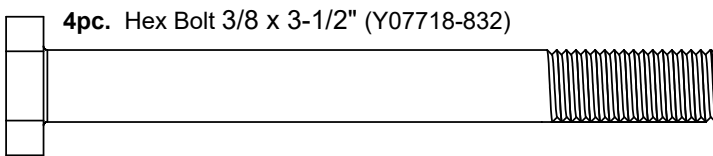
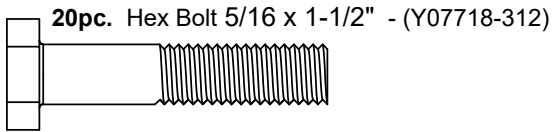
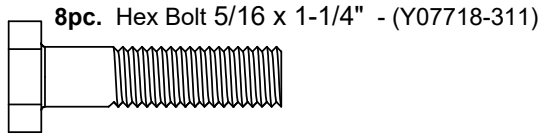
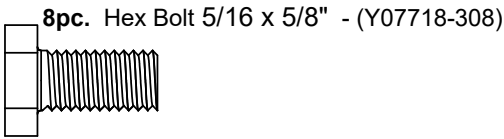
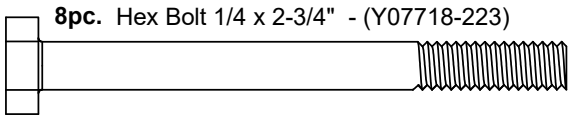

# Hardware Identification ( Dimensions are approximate and are shown to assist in the identification of parts for assembly. Actual dimensions may be smaller or larger. )

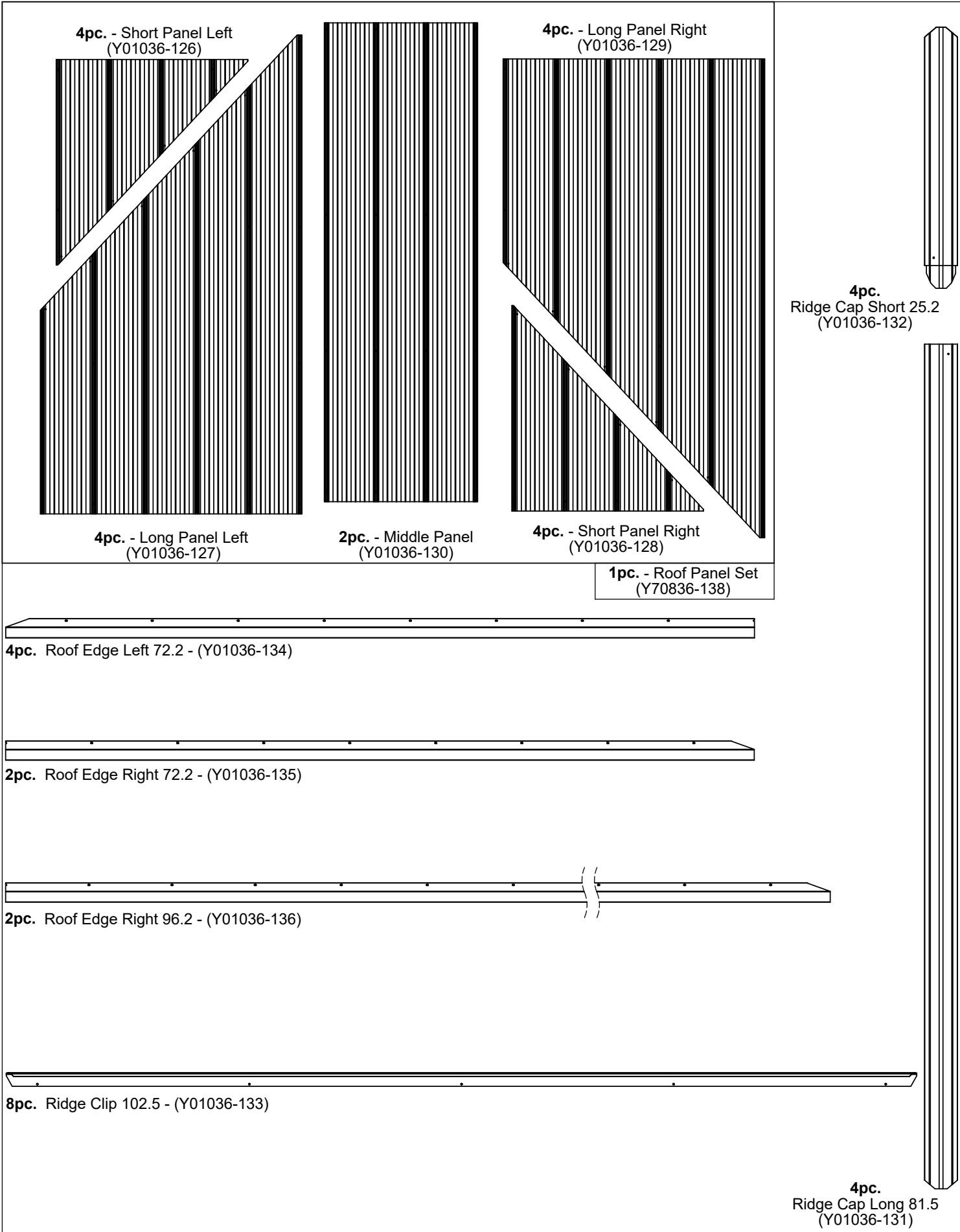

# Hardware Identification ( Dimensions are approximate and are shown to assist in the identification of parts for assembly. Actual dimensions may be smaller or larger. )

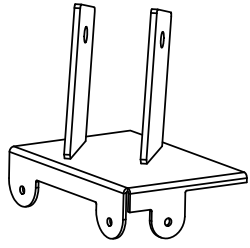

**1pc.**  
Post Top Bracket LT (2Pk)  
(Y70818-1148)

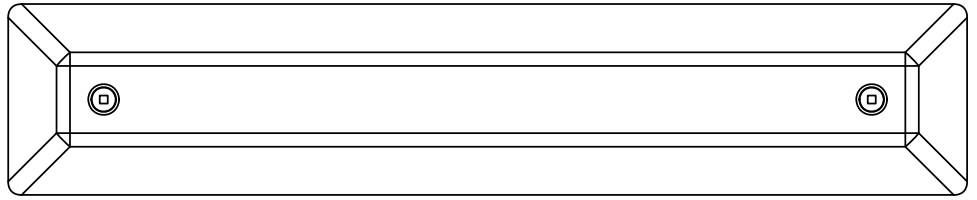

**1pc.** Peak Cap Long  
(Y01036-137)

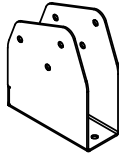

**1pc.**  
Tall Tie Wrap Bracket (4Pk)  
(Y70829-1202)

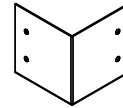

**1pc.** - Corner Cap Set (4Pk)  
(Y70836-103)



**1pc.** - Weather Seal -  
Ridge Clip (8Pk)  
(Y70818-074)

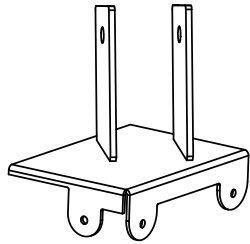

**1pc.**  
Post Top Bracket RT (2Pk)  
(Y70818-1147)

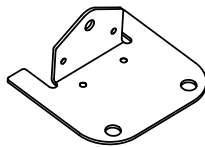

**1pc.** - Post  
Mount Set (8Pk)  
(Y70819-109)



**2pc.**  
Peak Post  
(Y01000-094)

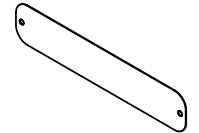

**1pc.** - Gazebo ID Plaque  
(Y70800-104)

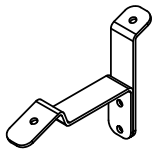

**1pc.** - Roof To Beam  
Bracket Set (14Pk)  
(Y70829-123)

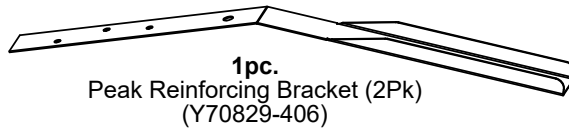

**1pc.**  
Peak Reinforcing Bracket (2Pk)  
(Y70829-406)

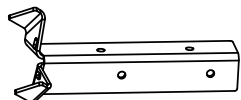

**1pc.** - Post to Rafter  
Connector Set (4Pk)  
(Y70818-840)



**2pc.** - Truss Connector Long  
(Y00441-838)

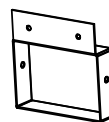

**2pc.** - Truss Connector Short  
(Y00441-839)

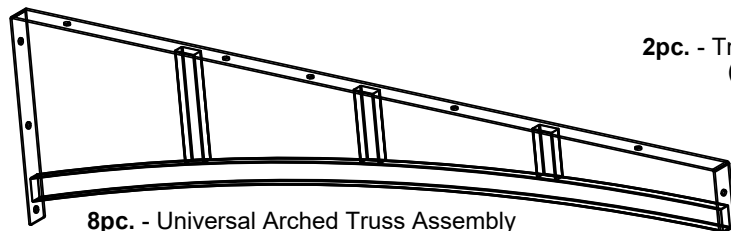

**8pc.** - Universal Arched Truss Assembly  
(Y70841-832)

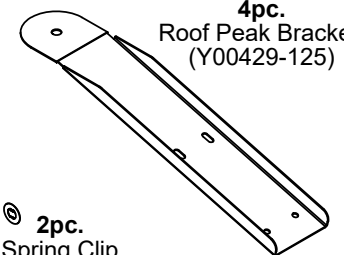

**4pc.**  
Roof Peak Bracket  
(Y00429-125)

**2pc.**  
Spring Clip  
(Y09490-001)

**2pc.**  
1/4" Nut  
(Y08490-200)



**2pc.**  
Carriage Bolt  
(Y07428-260)



**2pc.**  
Contoured Washer  
(Y05918-211)

**2pc.**  
Peak Loop  
(Y20018-003)



**1pc.** - Roof Peak Set  
(Y70829-125)

# Step 1: Inventory Parts - Read This Before Starting Assembly

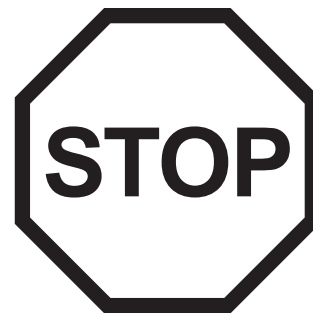
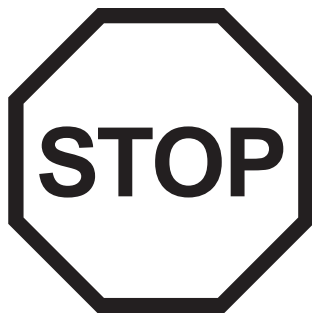

- A.** This is the time for you to inventory all your hardware, wood and accessories, referencing the parts identification sheets. This will assist you with your assembly.
- Each step indicates which bolts and/or screws you will need for assembly, as well as any flat washers, lock washers, t-nuts or lock nuts.
- B.** If there are any missing or damaged pieces or you need assistance with assembly please contact the consumer relations department directly. Call us before going back to the store.

**1-888-509-4382**

Regular Hours: Mon - Fri, 8:30 am - 5:00 pm EST (excl. holidays)  
English and French Spoken

**[support@yardistrystructures.com](mailto:support@yardistrystructures.com)**

- C.** Read the assembly manual completely, paying special attention to ANSI warnings; notes; and safety/maintenance information on pages 1 - 4.
- Follow the instructions in order.
  - This structure is designed to be assembled and installed ideally by four people, DO NOT attempt to install alone.
  - Consider the slope of elevation where you plan to install the structure. Also, check for gas, telephone, other utilities or sprinkler line locations prior to excavating any holes.
- D.** Before you discard your cartons fill out the form below.
- The carton I.D. stamp is located on the end of each carton.
  - Please retain this information for future reference. You will need this information if you contact the Consumer Relations Department.

**PRODUCT NUMBER: YM12983X**

CARTON I.D. STAMP: \_\_\_ \_\_\_ \_\_\_ \_\_\_ \_\_\_ 14459 \_\_\_ (Box 1)

CARTON I.D. STAMP: \_\_\_ \_\_\_ \_\_\_ \_\_\_ \_\_\_ 14459 \_\_\_ (Box 2)

CARTON I.D. STAMP: \_\_\_ \_\_\_ \_\_\_ \_\_\_ \_\_\_ 14459 \_\_\_ (Box 3)

# Step 2: Post Assemblies

## Part 1

**A:** At the bottom of one (1915) 6 x 8 Post Left Side and one (1916) 6 x 8 Post Right Side insert one 5/16" T-Nut on the outside of each short side. (F2.1 and F2.2)

**B:** At the bottom of each post place two Post Mounts tight to the bottom and inside faces on the short sides as shown in F2.1 and F2.2. Loosely attach with one 5/16 x 1-1/4" Hex Bolt (with 5/16" lock washer and 1/4-5/16" large washer) per mount so they connect to the T-Nuts. From the bottom attach with two #8 x 1-1/2" Wood Screws and from the inside with two #10 x 1-1/4" Pan Screws per mount. Tighten bolts.

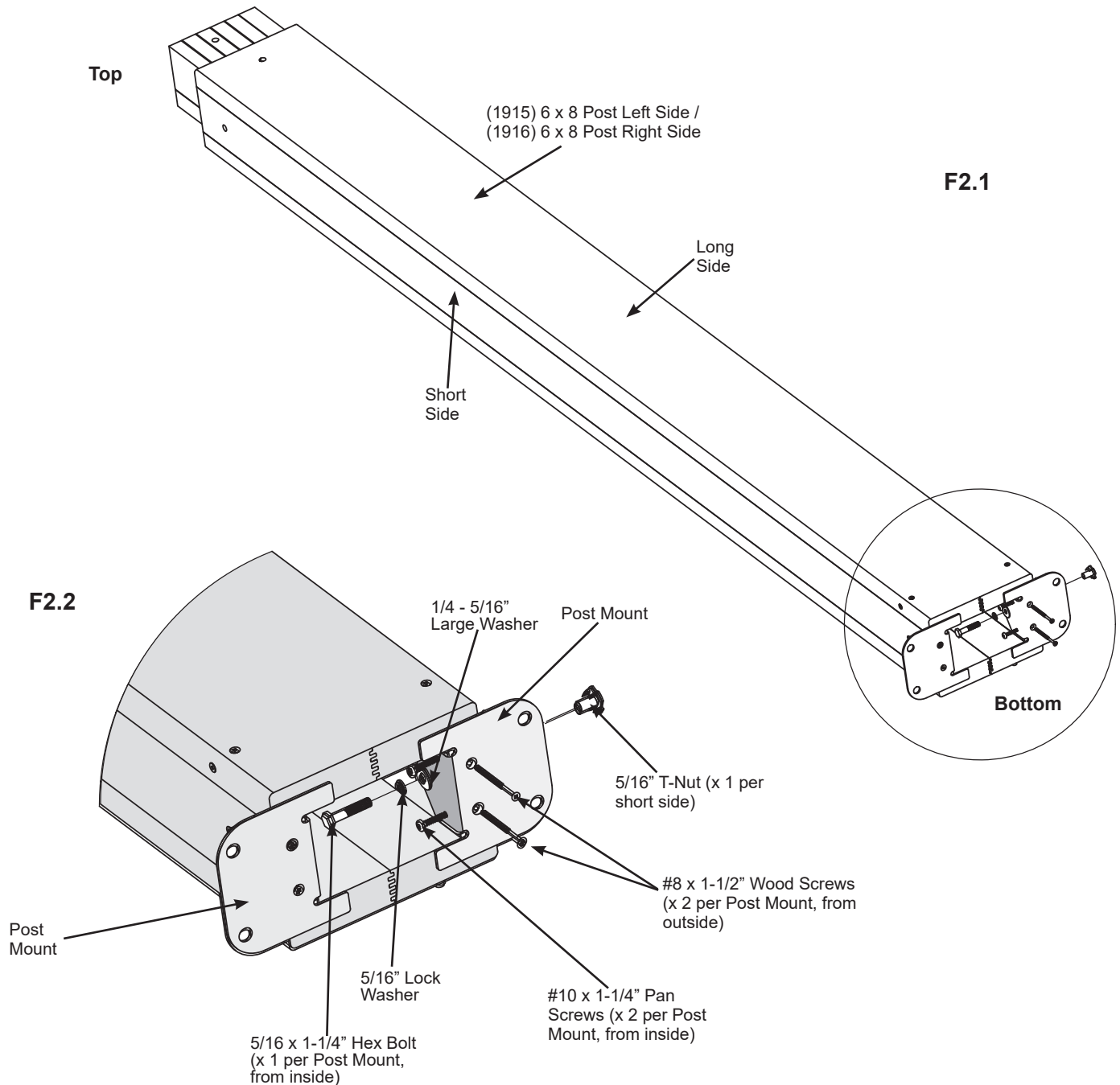

### Wood Parts

- 2 x (1915) 6 x 8 Post Left Side
- 2 x (1916) 6 x 8 Post Right Side

### Components:

- 8 x Post Mount

### Hardware

- 16 x #8 x 1-1/2" Wood Screw
- 16 x #10 x 1-1/4" Pan Screw Yellow
- 8 x 5/16 x 1-1/4" Hex Bolt (with 5/16" lock washer, 1/4 - 5/16" large washer, 5/16" t-nut)

## Step 2: Post Assemblies Part 2

**C:** Flush to the bottom of each (1915) 6 x 8 Post Left Side and each (1916) 6 x 8 Post Right Side place one (1048) Plinth Long on each long side and one (459) Plinth on each short side then attach with four #8 x 1-1/2" Wood Screws per plinth. Rounded edges on top. (F2.3 and F2.4)

**There will be two Post Left Assemblies and two Post Right Assemblies.**

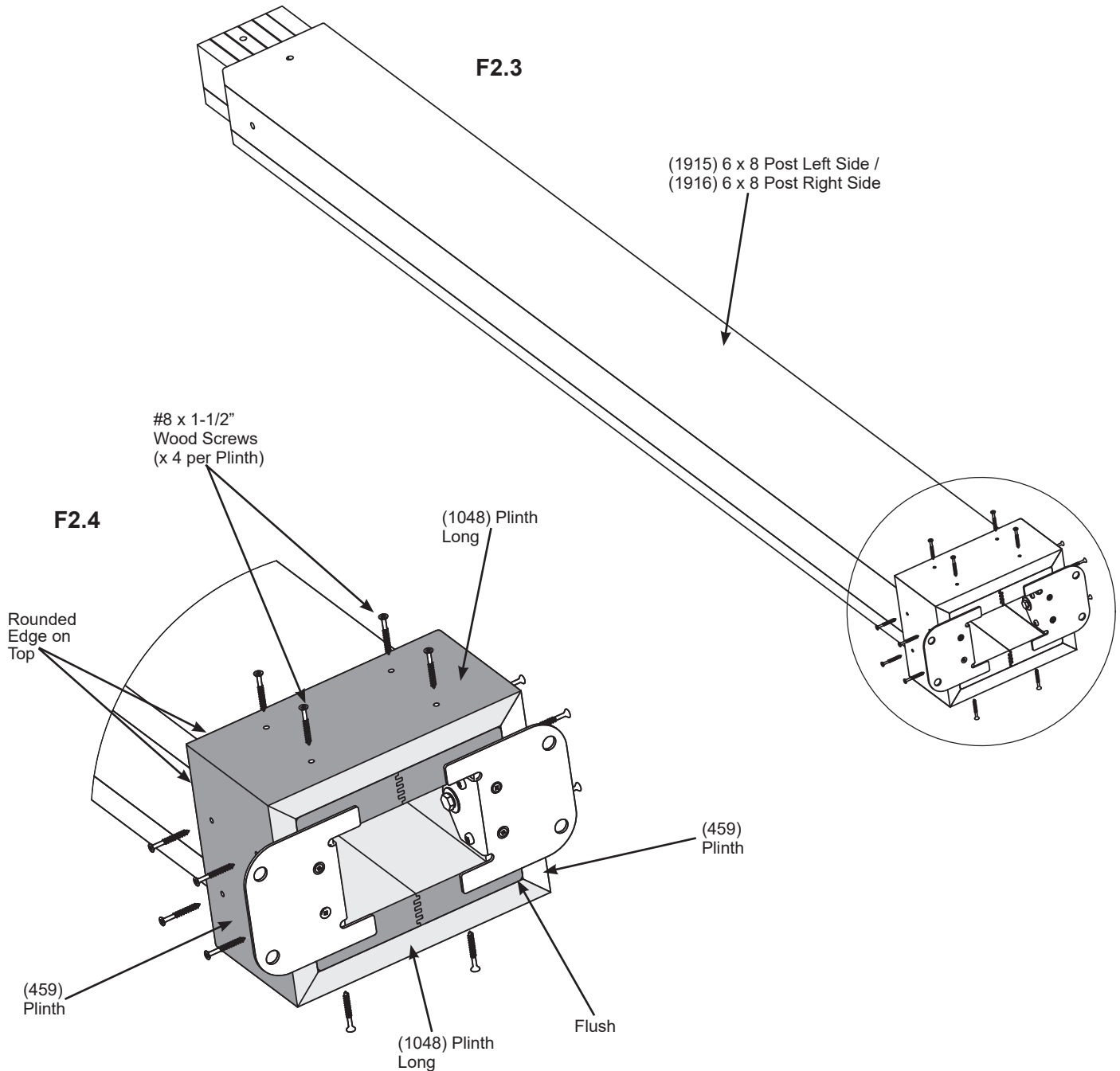

### Wood Parts

8 x (459) Plinth  
8 x (1048) Plinth Long

### Hardware

64 x #8 x 1-1/2" Wood Screw

## Step 3: Long Beam Assembly

**A:** Connect one (1912) Beam End Long to each end of one (1914) Beam Center Long using two 5/16 x 1-1/2" Hex Bolts (with 5/16" lock washer, 1/4-5/16" large washer and 5/16" t-nut) per end as shown in F3.1 and F3.2. Make sure t-nuts are installed in (1914) Beam Center Long (same side as grooves on (1912) Beam End Long).

**B:** Repeat Step A one more time to make two Long Beam End Assemblies.

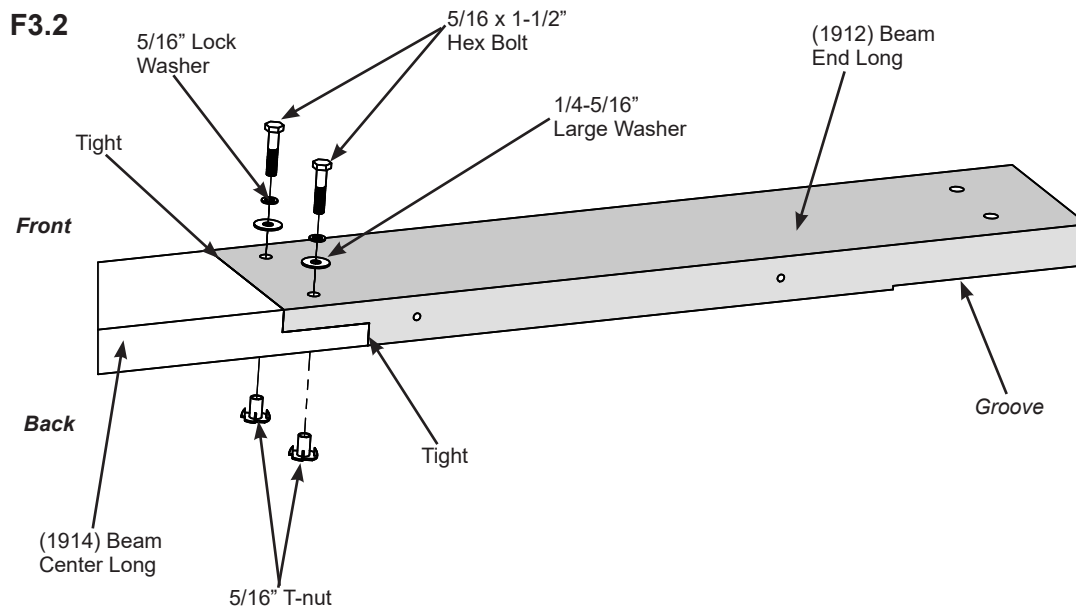
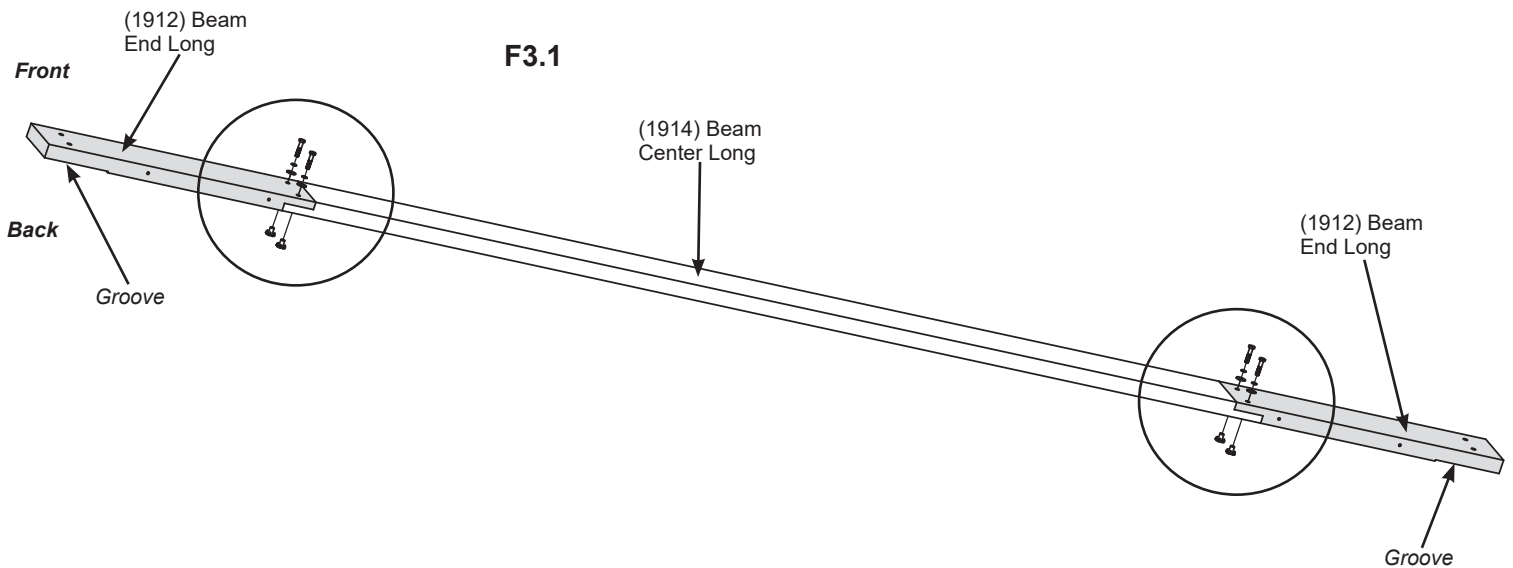

**Make sure bolt heads are on the front of each Beam Assembly**

### Wood Parts

- 4 x (1912) Beam End Long
- 2 x (1914) Beam Center Long

### Hardware

- 8 x 5/16 x 1-1/2" Hex Bolt  
(5/16" lock washer, 1/4-5/16" large washer, 5/16" t-nut)



# Step 5: Truss Assemblies

**A:** On each side of one Long Beam Connector place two Universal Arched Truss Assemblies then attach together using one 5/16 x 5/8" Hex Bolt (with two 5/16" flat washers and one 5/16" lock nut) per truss. Bolts inserted from the inside of the connector. (F5.1 and F5.2)

**B:** On each side of one Short Beam Connector place two Universal Arched Truss Assemblies then attach together using one 5/16 x 5/8" Hex Bolt (with two 5/16" flat washers and one 5/16" lock nut) per truss. Bolts inserted from the inside of the connector. (F5.3 and F5.4)

**C:** Repeat Steps A and B one more time to create two Long Truss Assemblies and two Short Truss Assemblies.

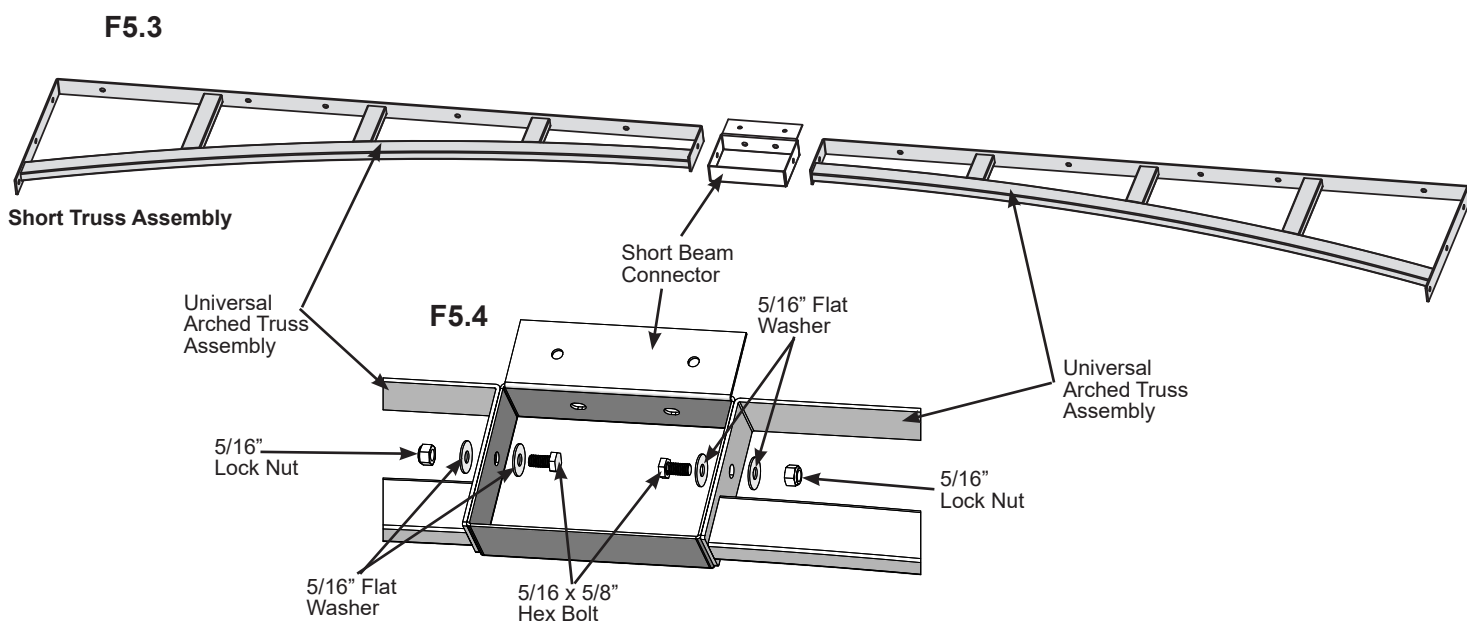
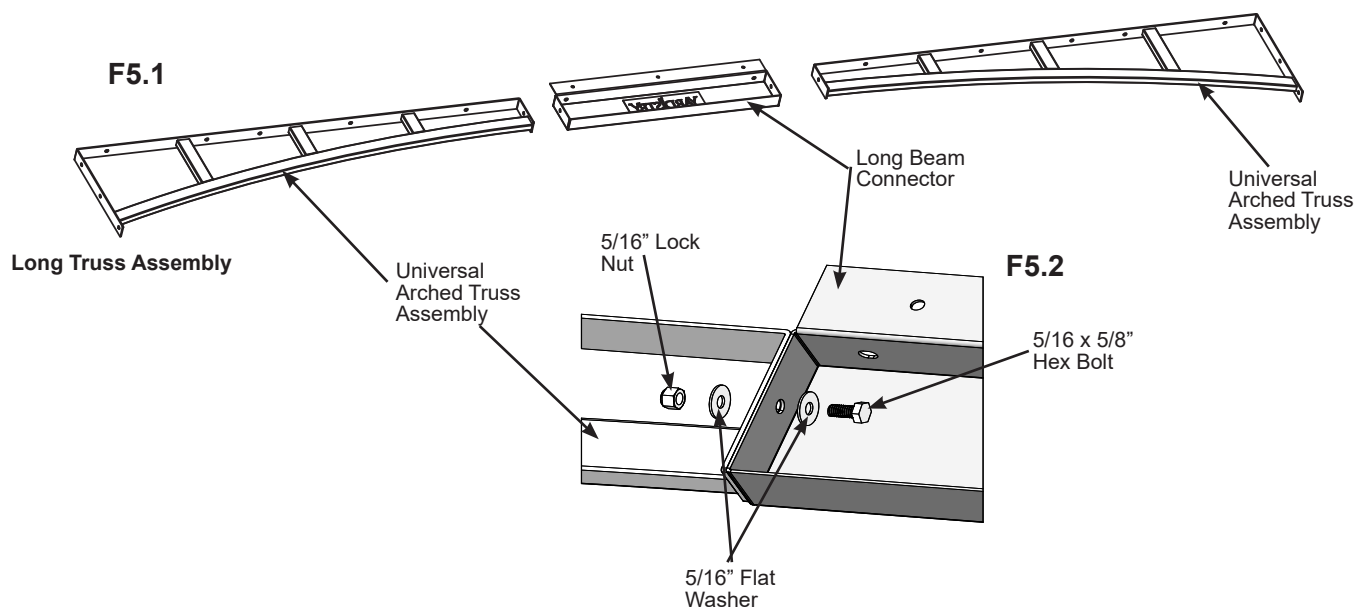

### Components

8 x Universal Arched Truss Assembly  
 2 x Long Beam Connector  
 2 x Short Beam Connector

### Hardware

8 x 5/16 x 5/8" Hex Bolt  
 (5/16" flat washer x 2, 5/16" lock nut)

# Step 6: Frame Assembly - Long Side Part 1

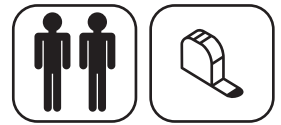

**A:** Place one Long Truss Assembly centered and tight to bottom of Long Beam Assembly. Make sure holes in Long Truss Assembly are lined up with pilot holes in Long Beam Assembly. Long Beam Assembly should overhang Short Truss Assembly by a minimum of 16.82 cm (6-5/8 in) on each side. Attach with twelve 5/16 x 2" Lag Screws (with 5/16" flat washer). (F6.1, F6.2 and F6.3)

**B:** Attach Long Beam Connector to Long Beam Assembly with two #10 x 1-1/4" Pan Screws - Black. (F6.2 and F6.4)

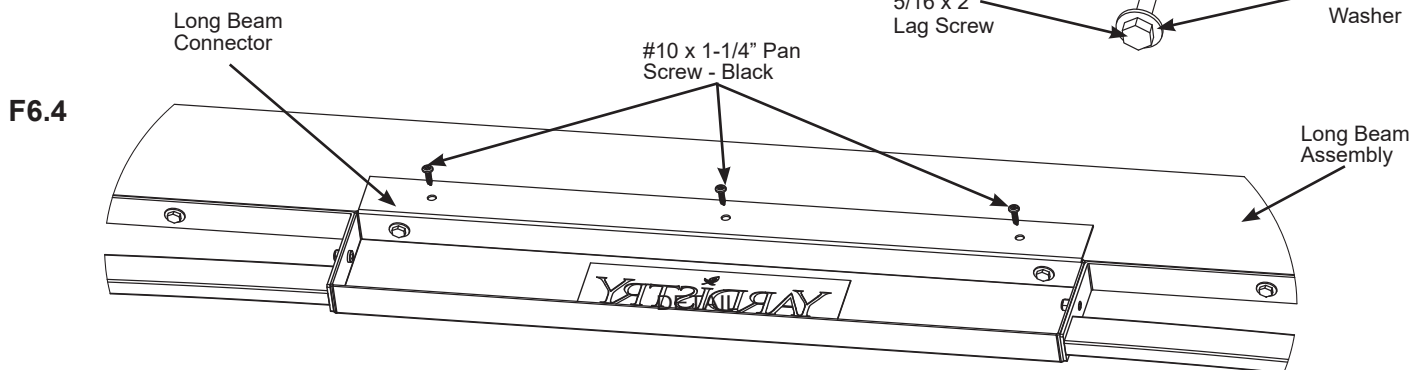
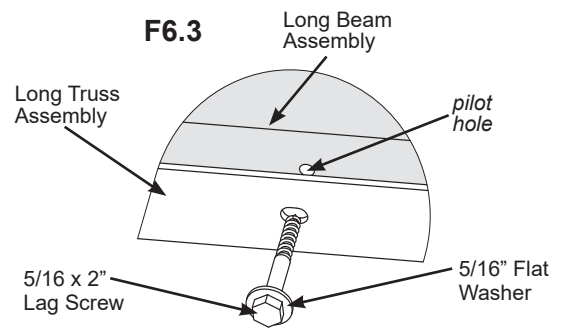
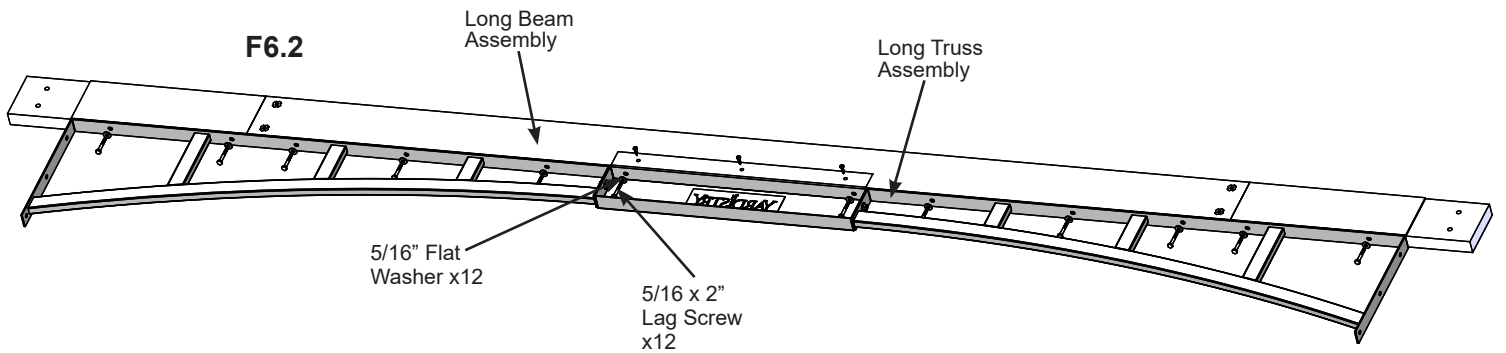
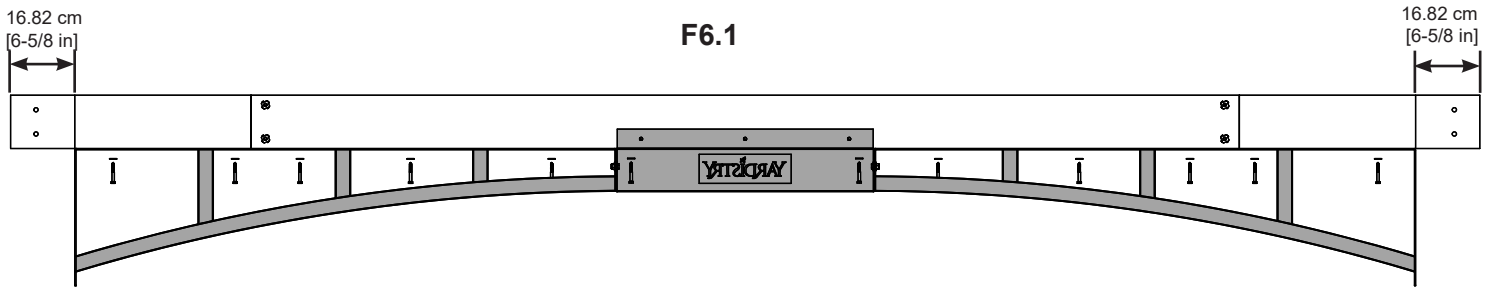

## Hardware

24 x 5/16 x 2" Lag Screw (5/16" flat washer)

6 x #10 x 1-1/4" Pan Screw - Black

# Step 6: Frame Assembly - Long Side Part 2

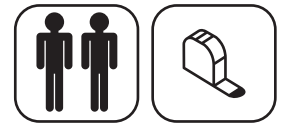

**C:** Against the long sides of one Post Right Assembly and one Post Left Assembly place one Long Side Assembly with grooves against the posts, then loosely attach with one 3/8 x 6-1/2" Hex Bolt (with two 3/8" large washers and one 3/8" lock nut) per post in the bottom holes. The distance from the outside of one post to the outside of the second post should be 3.92 m (12 ft 10-3/8 in). (F6.5, F6.6 and F6.7)

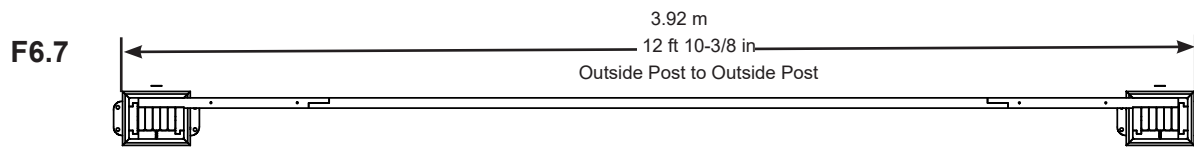
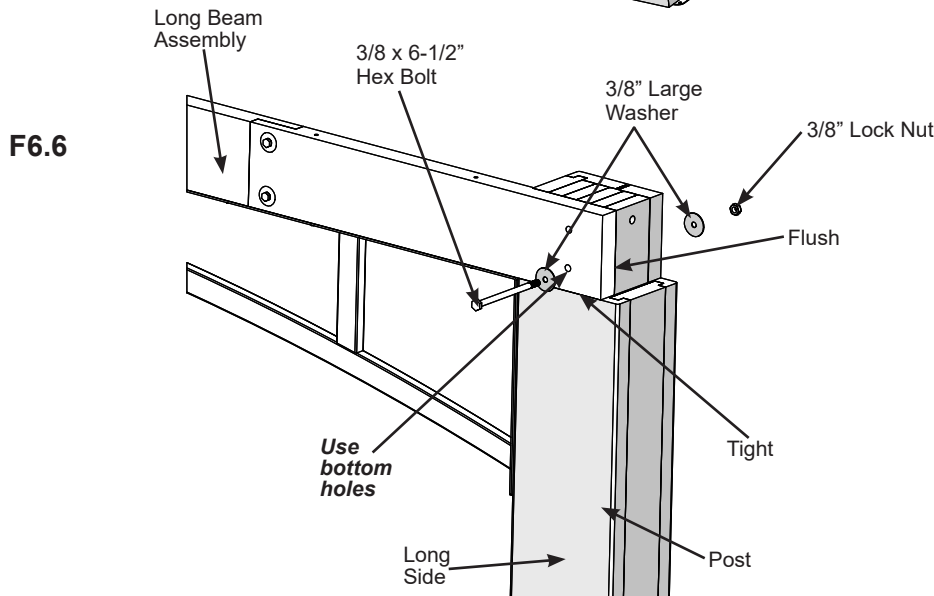
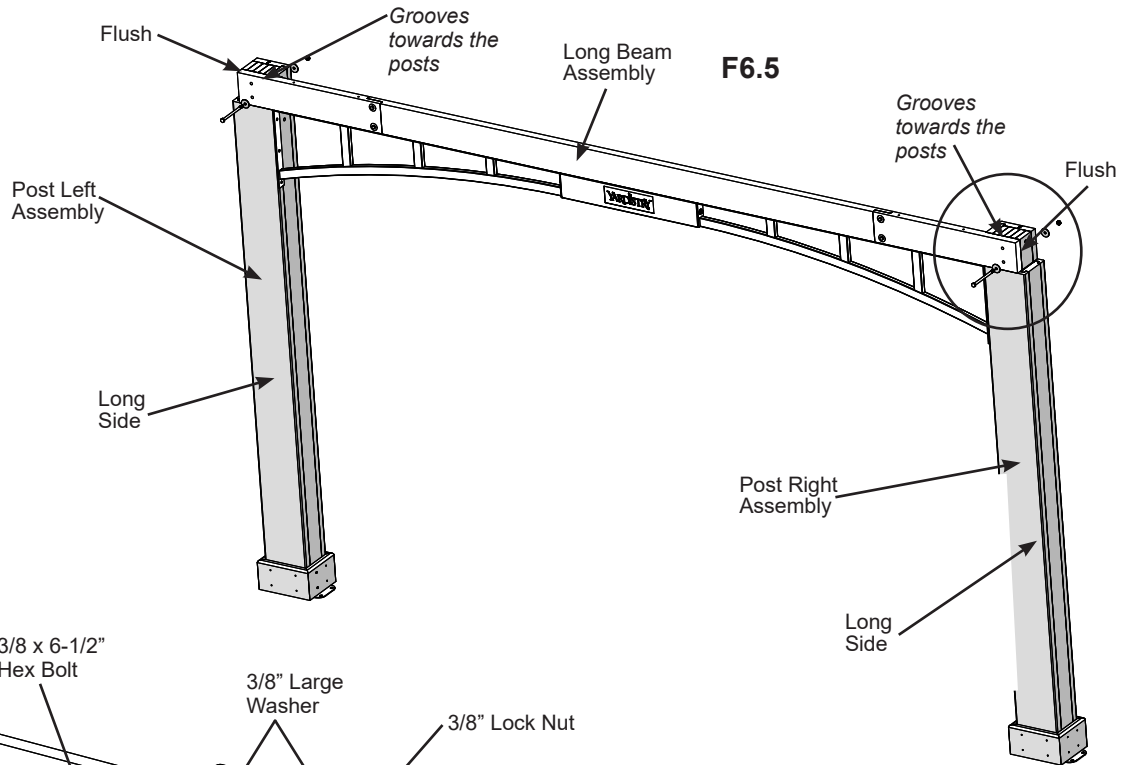

### Hardware

4 x 3/8 x 6-1/2" Hex Bolt (3/8" large washer x 2, 3/8" lock nut)

# Step 6: Frame Assembly - Long Side Part 3



**D:** Make sure Long Truss Assembly is square to posts and flush to the outside of the posts then pre-drill with a 1/8" drill bit and attach Long Truss Assembly to posts using three 5/16 x 3" Lag Screws (with 5/16" flat washer) per post. (F6.8 and F6.9)

**E:** Pre-drill with a 1/8" drill bit in the top holes of Long Beam Assembly then attach to posts with one 5/16 x 3" Lag Screw (with 1/4-5/16" large washer) per side. Tighten all bolts. (F6.10)

**F:** Repeat Step A-E to create a second Long Side Assembly.

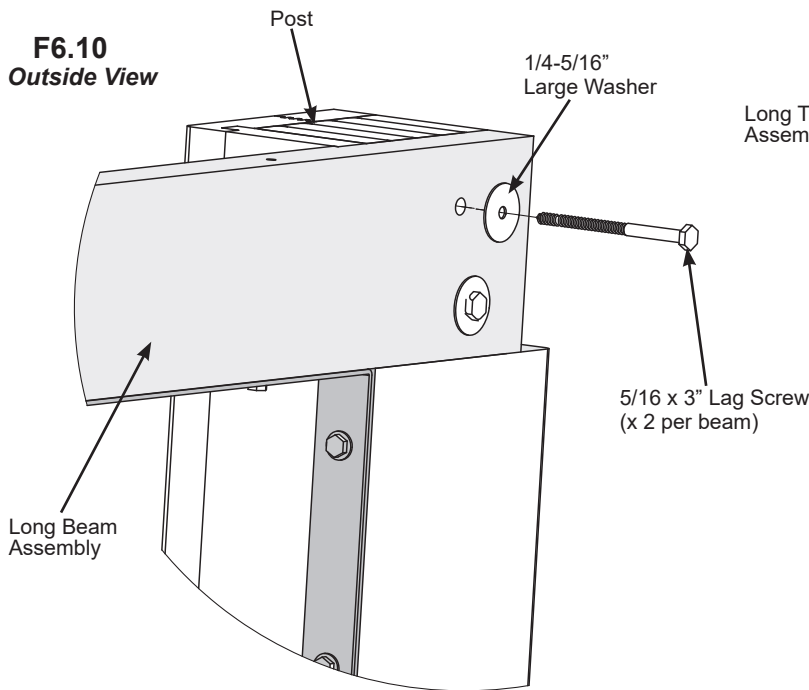
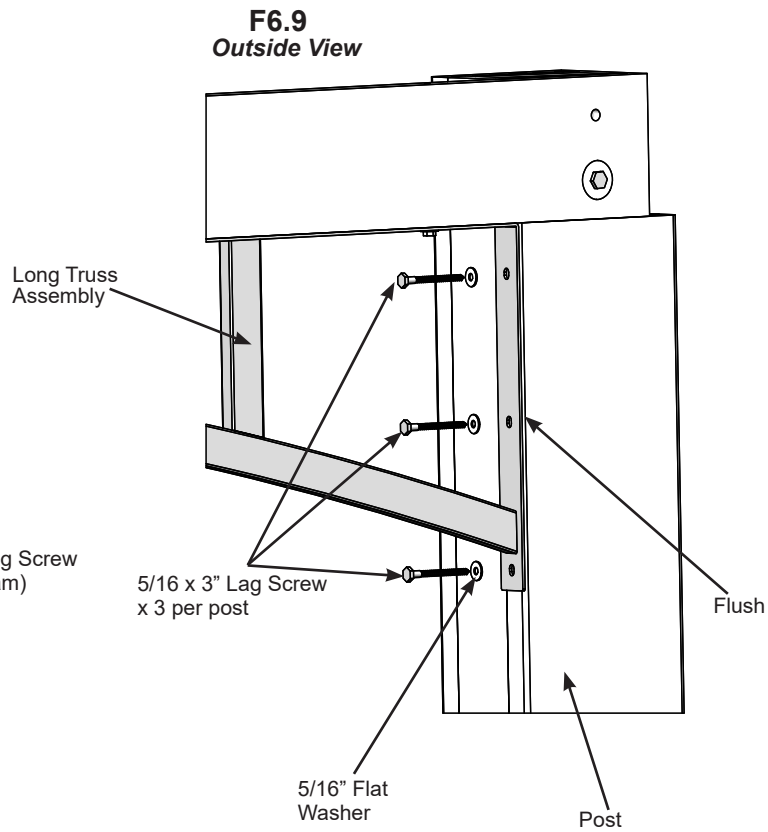
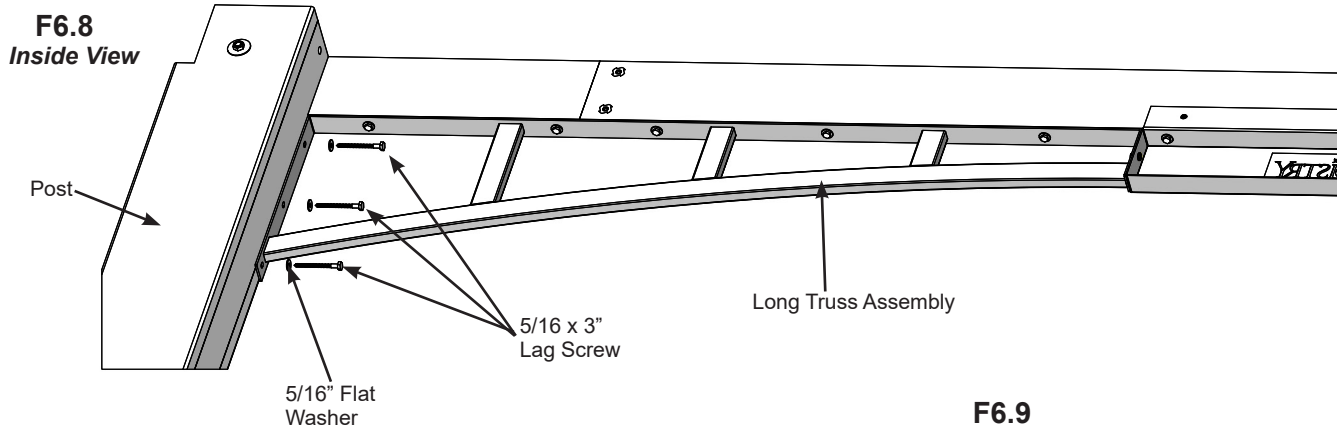

### Hardware

- 12 x 5/16 x 3" Lag Screw (5/16" flat washer)
- 4 x 5/16 x 3" Lag Screw (1/4-5/16" large washer)

# Step 7: Frame Assembly - Short Side Part 1

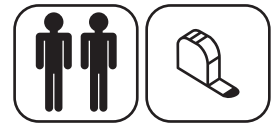

**A:** Place one Short Truss Assembly centered and tight to bottom of Short Beam Assembly. Make sure holes in Short Truss Assembly are lined up with pilot holes in Short Beam Assembly. Short Beam Assembly should overhang Short Truss Assembly by a minimum of 15.24 cm (6 in) on each side. In the end holes attach with two 5/16 x 2" Lag Screws (with 5/16" flat washer). (F7.1, F7.2 and F7.3)

**B:** Attach Short Beam Connector to both sides of Short Beam Assembly with two #10 x 1-1/4" Pan Screws - Black. (F7.1 and F7.4)

**C:** Repeat Step A and B to create a second Short Side Assembly.

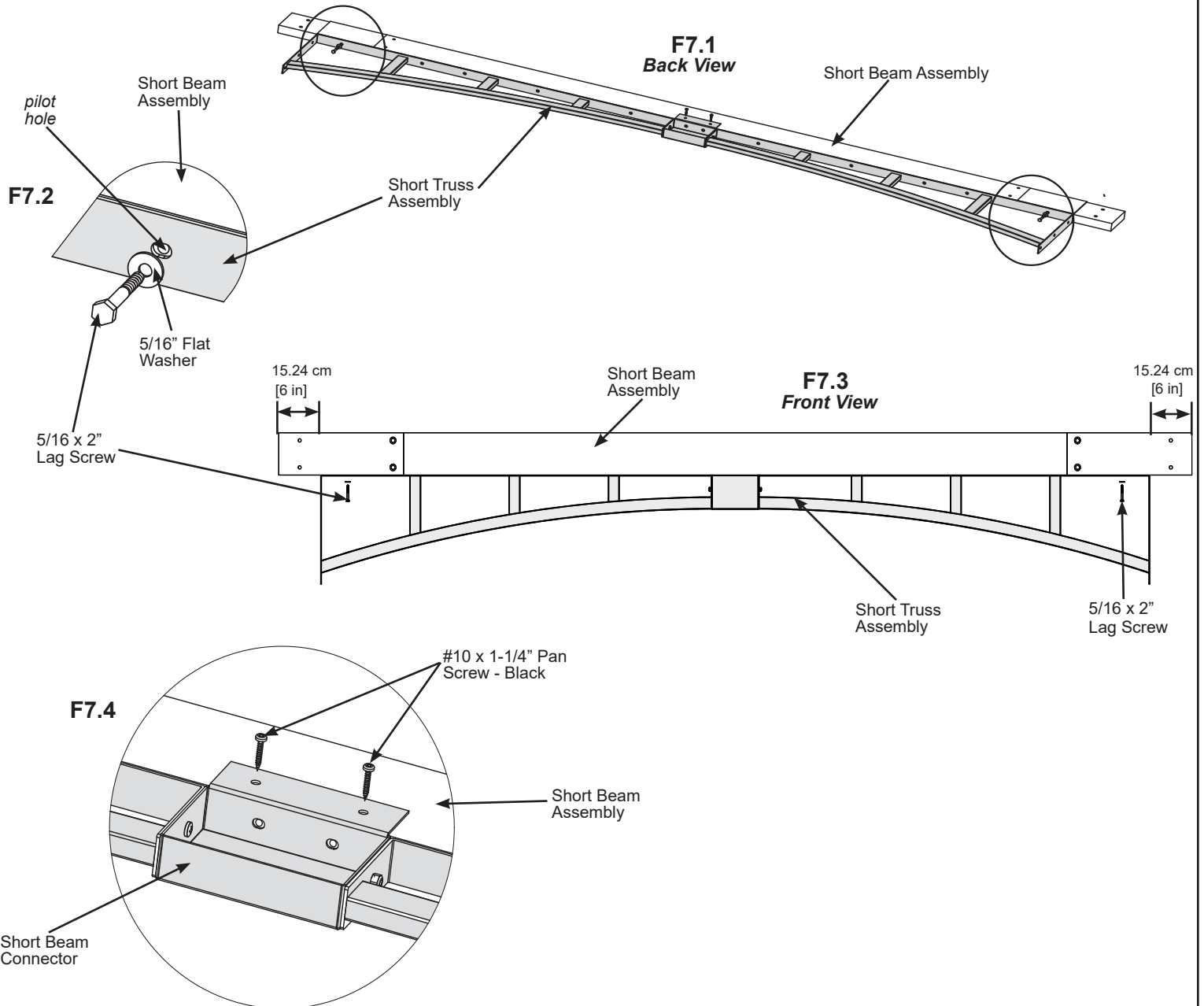

## Hardware

- 4 x 5/16 x 2" Lag Screw (5/16" flat washer)
- 4 x #10 x 1-1/4" Pan Screw - Black

# Step 7: Frame Assembly - Short Side Part 2

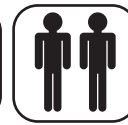

**D:** Move your Post Assemblies to the final location. Make sure the ground is flat and level before continuing assembly.

**E:** Stand each Long Side Assembly then place each Short Beam Assembly, with grooves against the posts, flush to the tops and tight to the Long Side Assemblies. Loosely attach Short Beam Assemblies to posts with one 3/8 x 8-1/2" Hex Bolt (with two 3/8" large washers and one 3/8" lock nut) per post in the top holes. The distance from the outside of one post to the outside of the second post should be 3.31m (10 ft 10-3/8 in). (F7.5, F7.6 and F7.7) Check F7.8 for accurate positioning of posts.

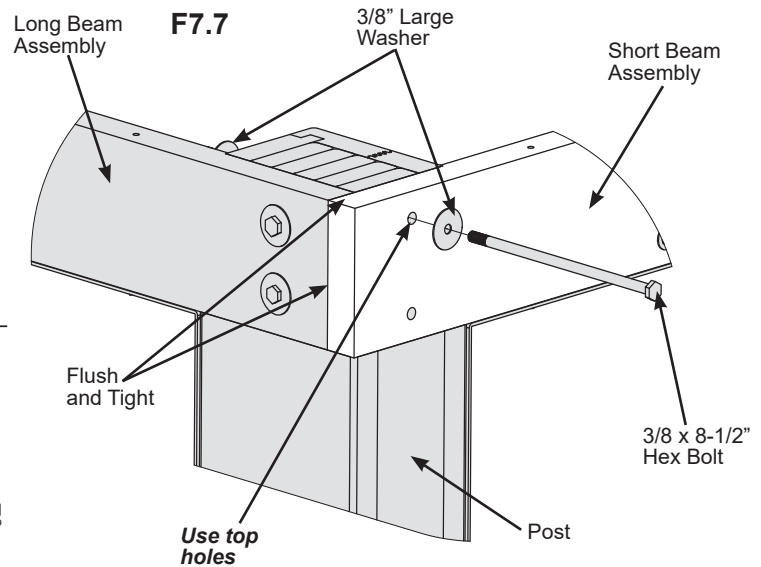
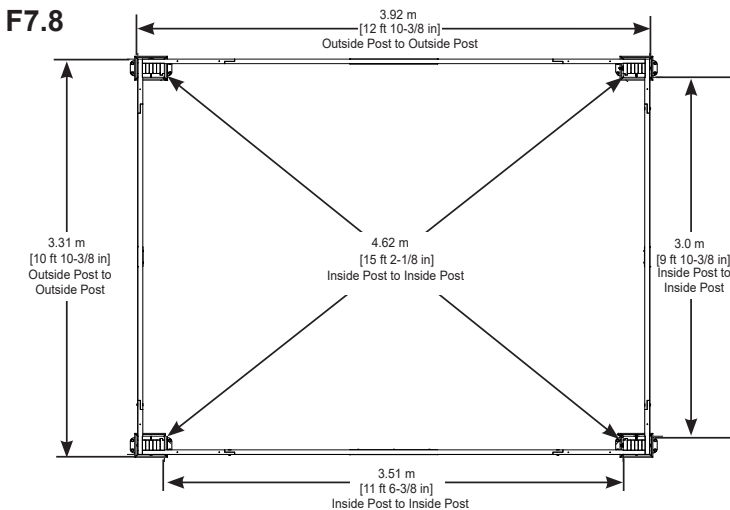
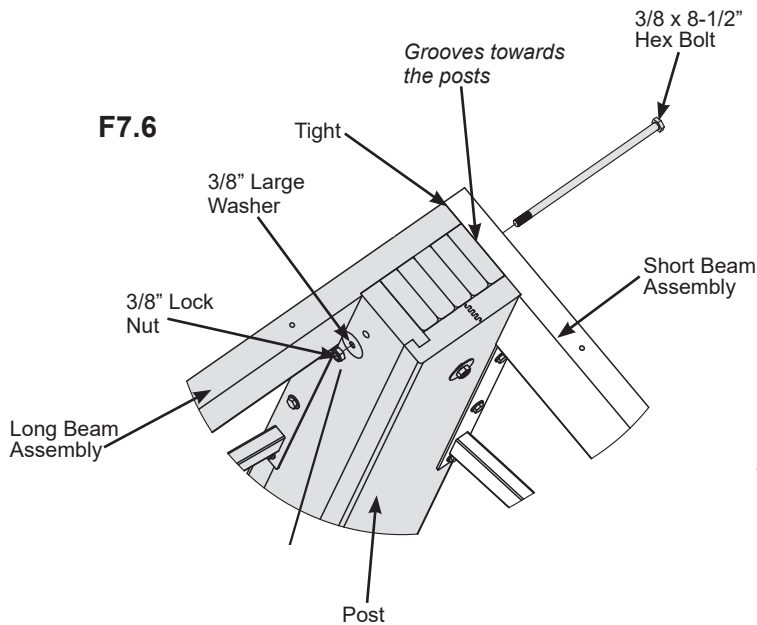
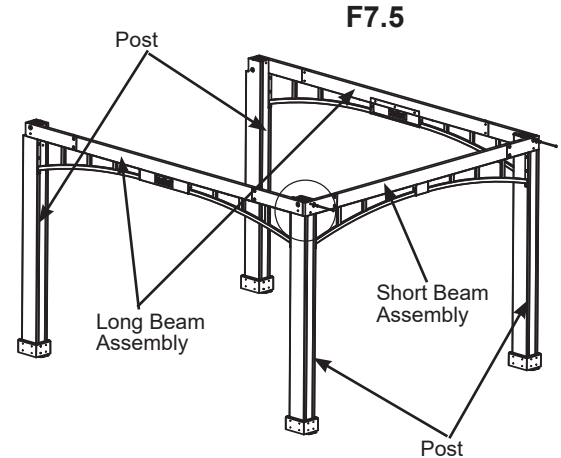

## Hardware

4 x 3/8 x 8-1/2" Hex Bolt (3/8" large washer x 2, 3/8" lock nut)

# Step 7: Frame Assembly - Short Side Part 3

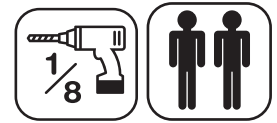

**F:** Make sure Short Truss Assemblies are square to posts and flush to the outside of the posts then pre-drill with a 1/8" drill bit and attach Short Truss Assemblies to posts using three 5/16 x 3" Lag Screws (with 5/16" flat washer) per post. (F7.9 and F7.10)

**G:** Pre-drill with a 1/8" drill bit in the bottom holes of Short Beam Assemblies then attach to posts with one 5/16 x 3" Lag Screw (with 1/4-5/16" large washer) per side. Tighten all bolts. (F7.11)

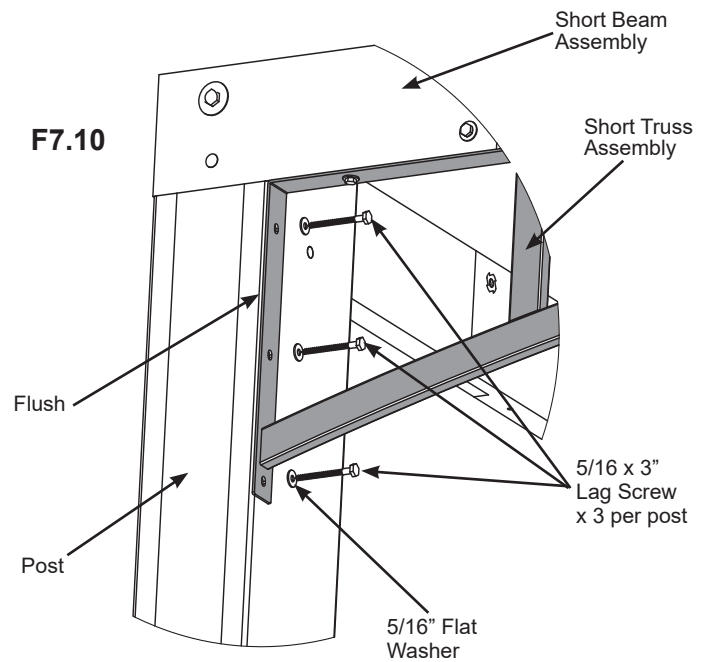
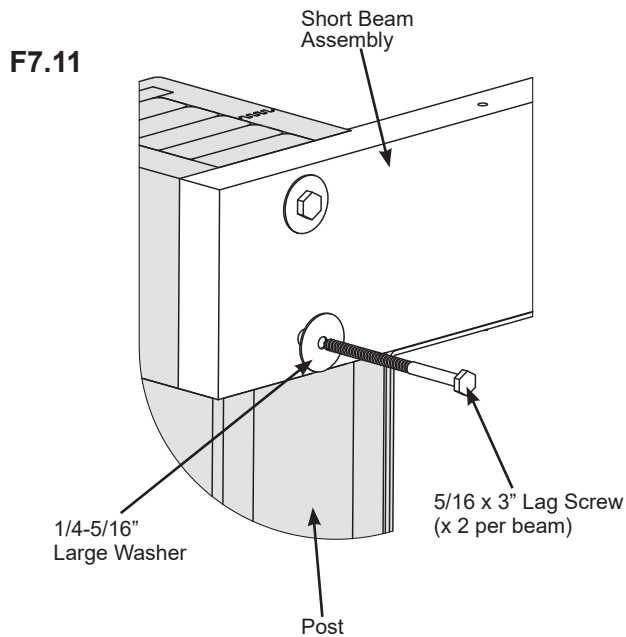
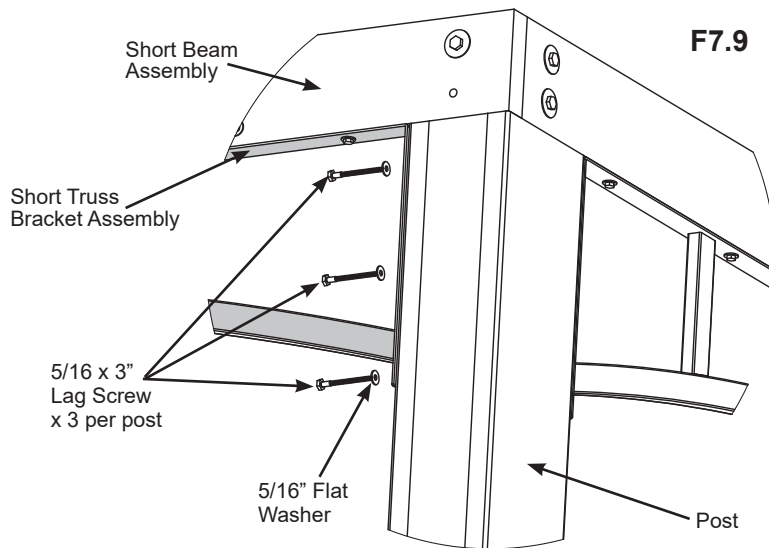

## Hardware

- 12 x 5/16 x 3" Lag Screw (5/16" flat washer)
- 4 x 5/16 x 3" Lag Screw (1/4-5/16" large washer)

# Step 7: Frame Assembly - Short Side Part 4

H: Make sure remaining holes in Short Truss Assemblies are lined up with pilot holes in Short Beam Assemblies then attach with ten 5/16 x 2" Lag Screws (with 5/16" flat washer) per assembly. (F7.12 and F7.13)

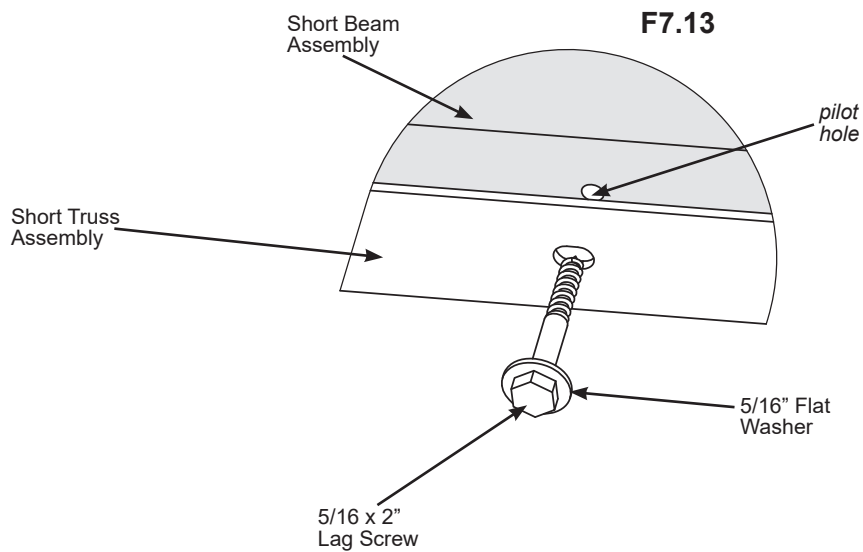
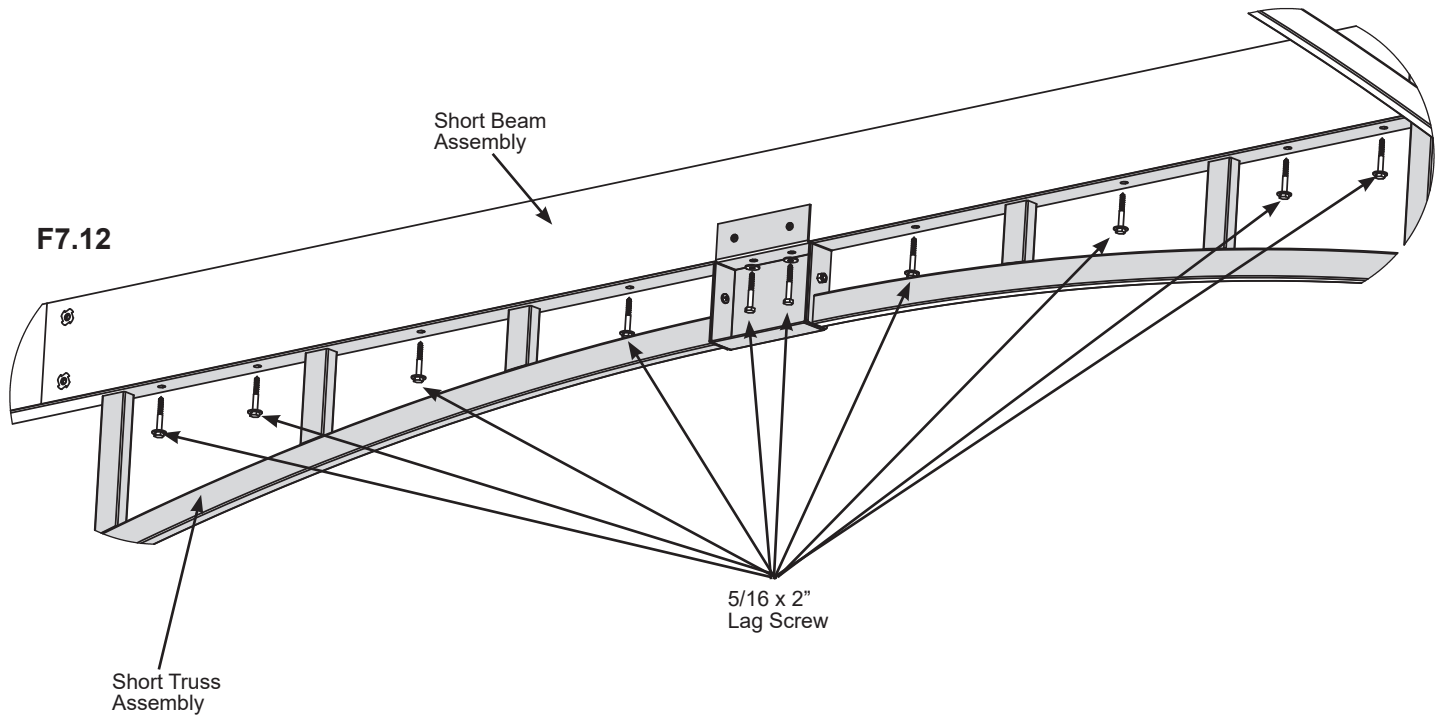

## Hardware

20 x 5/16 x 2" Lag Screw (5/16" flat washer)

# Step 8: Attach Roof Brackets



**A:** At each corner, flush to the bottom of the Short Beam Assemblies attach one Post to Rafter Connector with four #10 x 1-1/4" Pan Screws - Black. (F8.1 and F8.2)

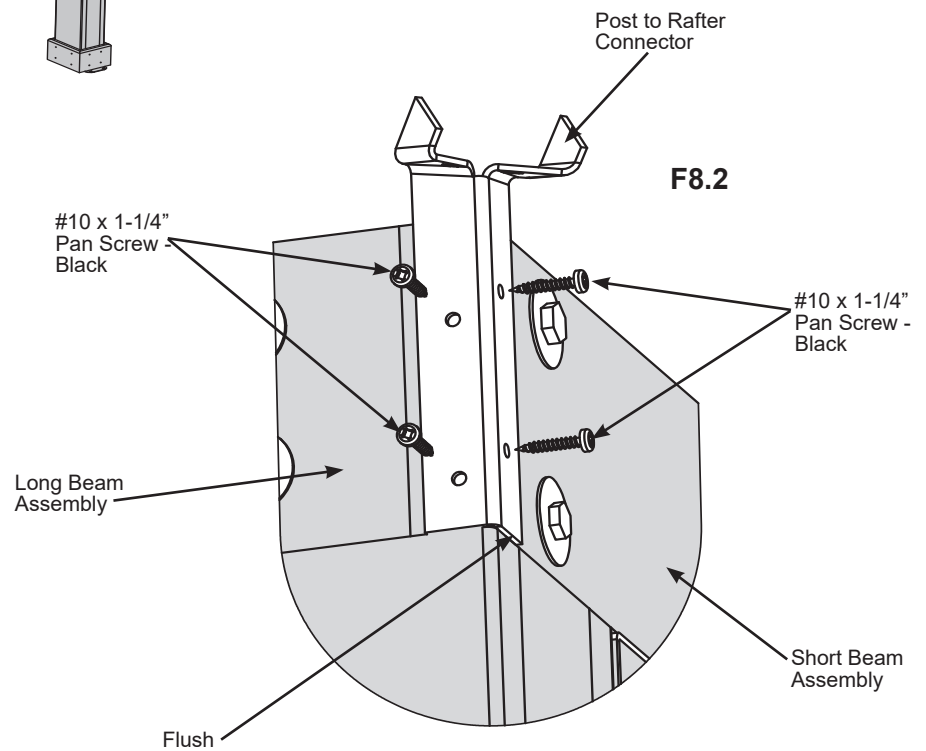
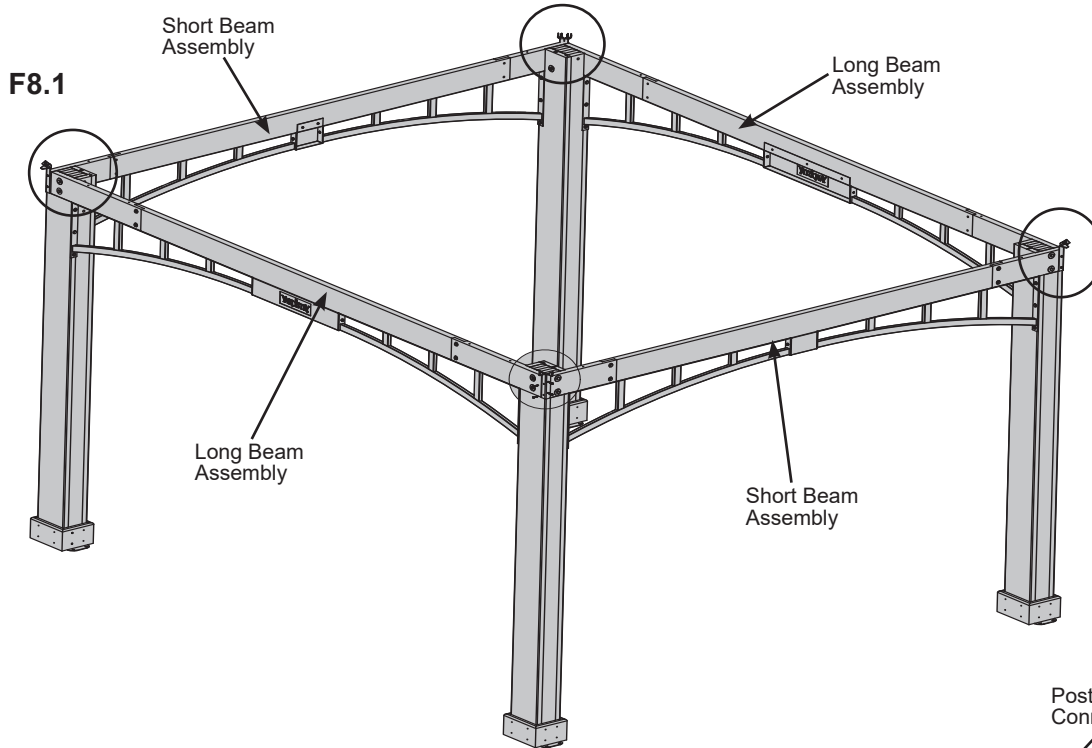

### Components

4 x Post to Rafter Connector

### Hardware

16 x #10 x 1-1/4" Pan Screw - Black

# Step 9: Fascia Beam Assemblies

**A:** Tightly connect one (443) Fascia Left and one (444) Fascia Right using one 5/16 x 1-1/2" Hex Bolt (with 5/16" lock washer, 1/4-5/16" large washer and 5/16" t-nut) as shown in F9.1 and F9.2. Repeat to make a second Fascia Beam Assembly.

**B:** Tightly connect one (435) Fascia Left - Large Roof and one (436) Fascia Right - Large Roof using one 5/16 x 1-1/2" Hex Bolt (with 5/16" lock washer, 1/4-5/16" large washer and 5/16" t-nut) as shown in F9.3 and F9.4. Repeat to make a second Large Fascia Beam Assembly.

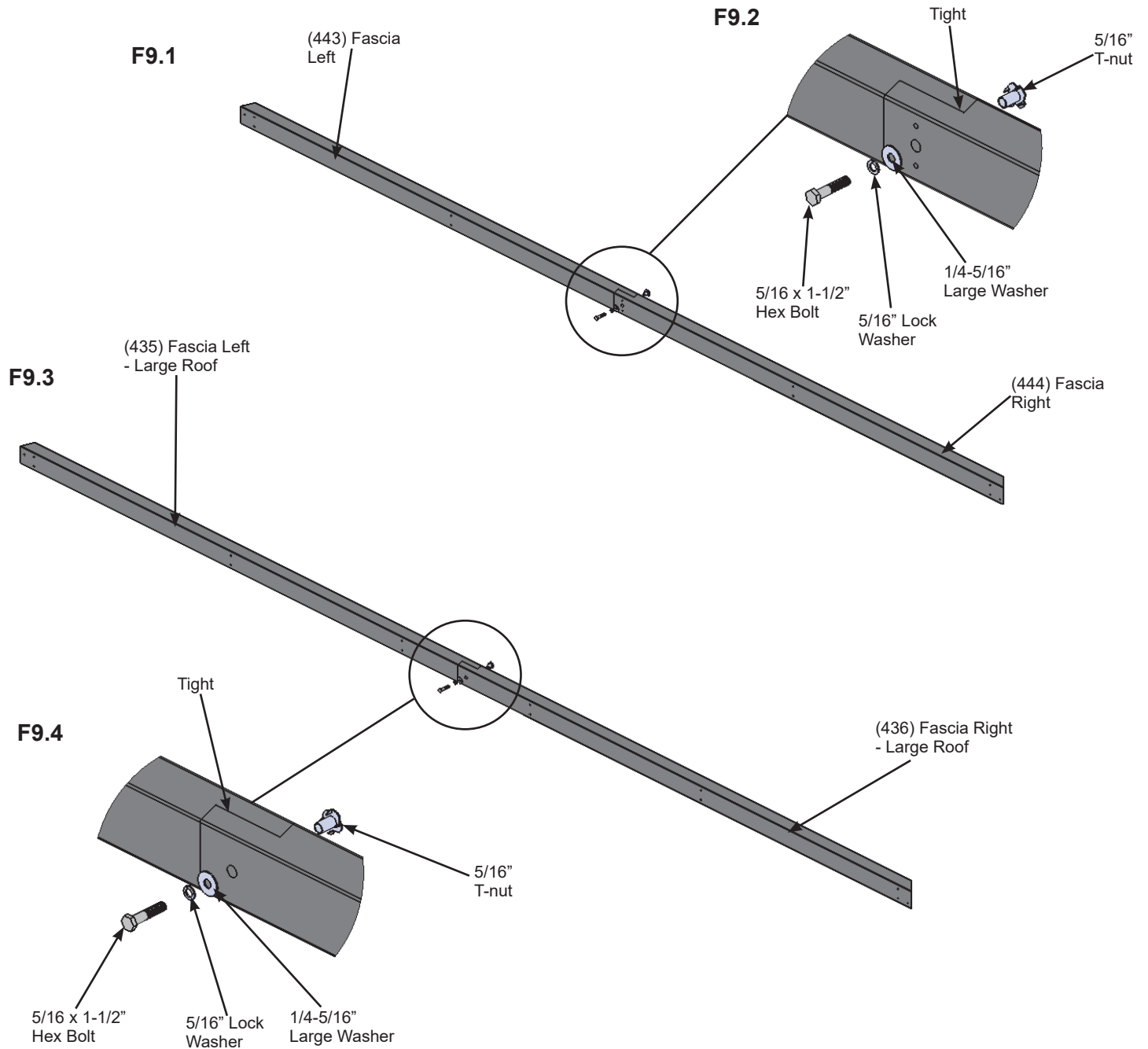

## Wood Parts

- 2 x (443) Fascia Left
- 2 x (444) Fascia Right
- 2 x (435) Fascia Left - Large Roof
- 2 x (436) Fascia Right - Large Roof

## Hardware

- 4 x 5/16 x 1-1/2" Hex Bolt  
(5/16" lock washer, 1/4-5/16" large washer, 5/16" t-nut)

# Step 10: Small Roof Rafter Assembly Part 1

**A:** On each side of one (440) Rafter place one (2342) Rafter Corner Left and one (2343) Rafter Corner Right so the tops and edges are flush then attach with two #8 x 2-1/4" Wood Screws per side. (F10.1 and F10.2)

**B:** Place Fascia Beam Assembly from Step 9A on the bottom of (2342) Rafter Corner Left, (2343) Rafter Corner Right and (440) Rafter so the sides are flush then attach with two #8 x 2-1/4" Wood Screws at each end and two in the middle. (F10.1, F10.3 and F10.4)

**C:** Repeat Steps A and B to make a second Small Roof Rafter Assembly.

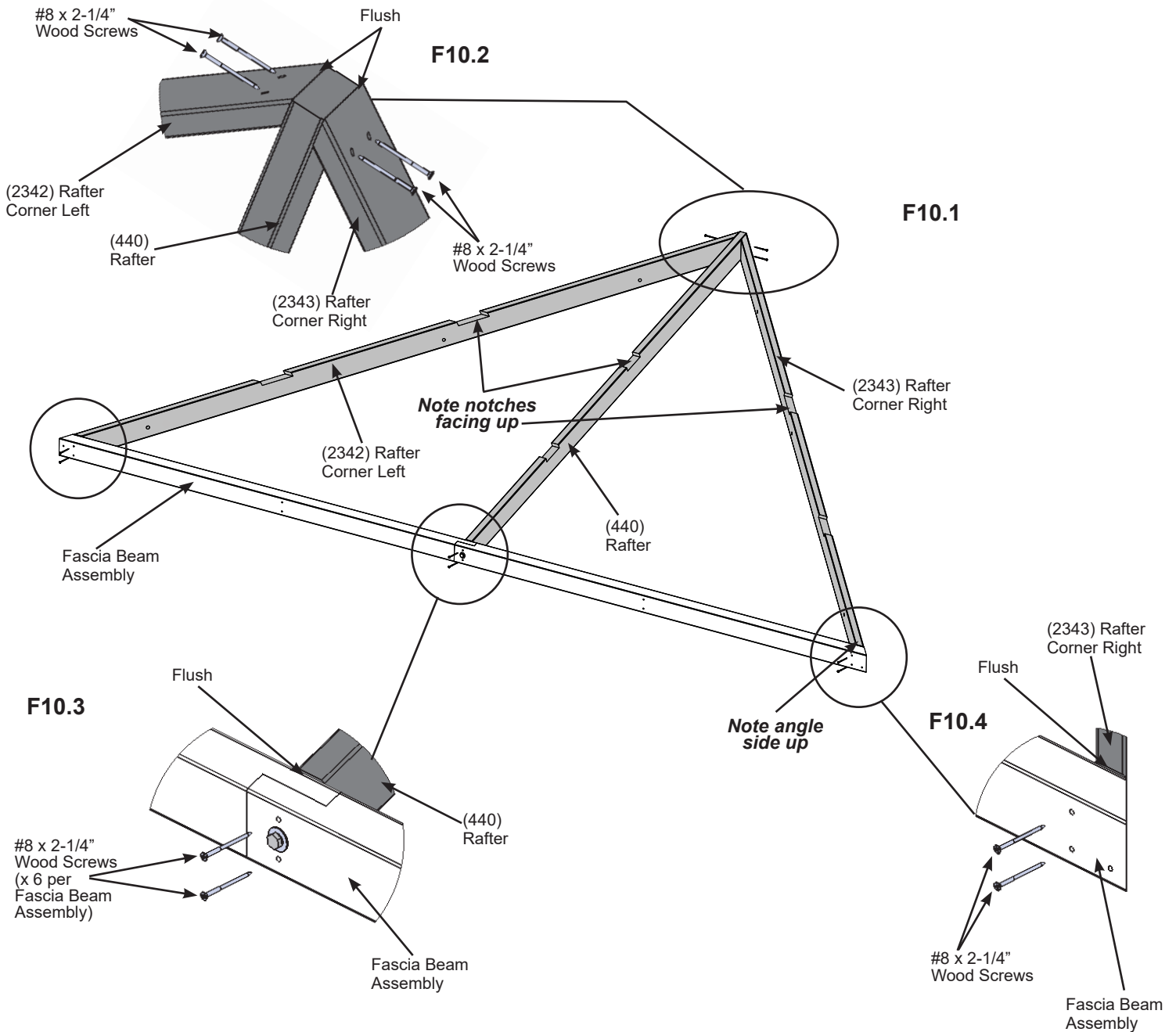

### Wood Parts

- 2 x (440) Rafter
- 2 x (2342) Rafter Corner Left
- 2 x (2343) Rafter Corner Right

### Hardware

- 20 x #8 x 2-1/4" Wood Screw

# Step 10: Small Roof Rafter Assembly Part 2

**D:** Place one (337) Strap Short in the notches of (2342) Rafter Corner Left, (2343) Rafter Corner Right and (440) Rafter so the ends do not overhang the outside edges of the outside boards then attach with six #8 x 1-1/2" Wood Screws. (F10.5)

**E:** Place one (437) Strap in the notches of (2342) Rafter Corner Left, (2343) Rafter Corner Right and (440) Rafter so the ends do not overhang the outside edges of the outside boards. Do not attach yet. (F10.5)

**F:** Place one (442) Rafter Short Right and one (441) Rafter Short Left in the notches of (437) Strap and attach as shown in F10.5 with four #8 x 1-1/2" Wood Screws and two #8 x 2-1/4" Wood Screws per board.

**G:** Attach (437) Strap to (2342) Rafter Corner Left, (2343) Rafter Corner Right and (440) Rafter with six #8 x 1-1/2" Wood Screws. (F10.5)

**H:** Complete Steps D, E, F and G for both Small Roof Rafter Assemblies.

## F10.5

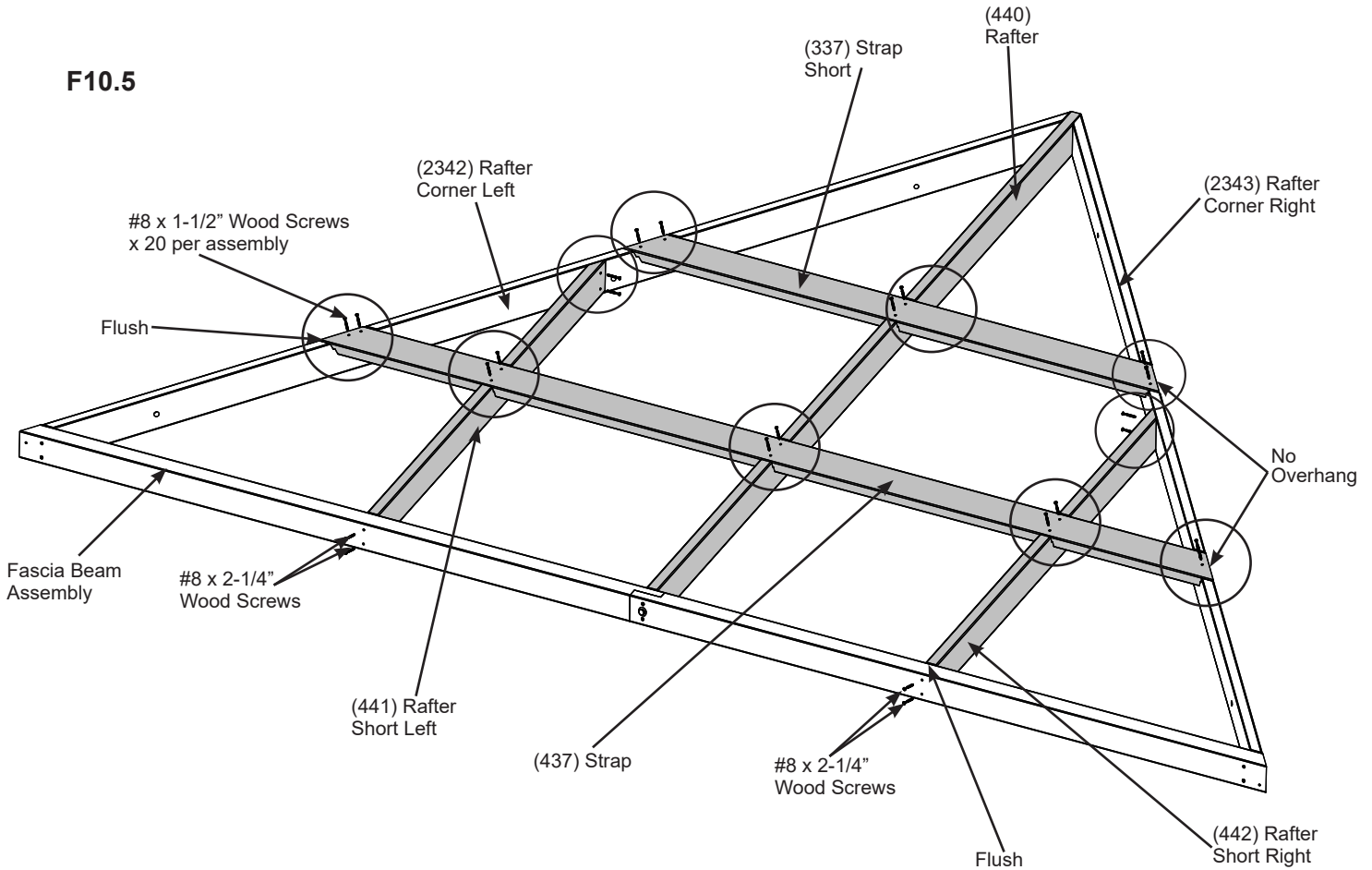

### Wood Parts

- 2 x (337) Strap Short
- 2 x (437) Strap
- 2 x (442) Rafter Short Right
- 2 x (441) Rafter Short Left

### Hardware

- 40 x #8 x 1-1/2" Wood Screw
- 8 x #8 x 2-1/4" Wood Screw

# Step 11: Attach Roof to Beam Brackets - Small Roof Rafter Assembly



**A:** On the Back of one Small Roof Rafter Assembly, centered and 3.81 cm (1.5 in) from the bottom of (442) Rafter Short Right, (441) Rafter Short Left and (440) Rafter attach one Roof to Beam Bracket per board with two #12 x 1-1/2" Pan Screws per bracket. Make sure to only install on one Small Roof Rafter Assembly, the second will not have brackets. (F11.1 and F11.2)

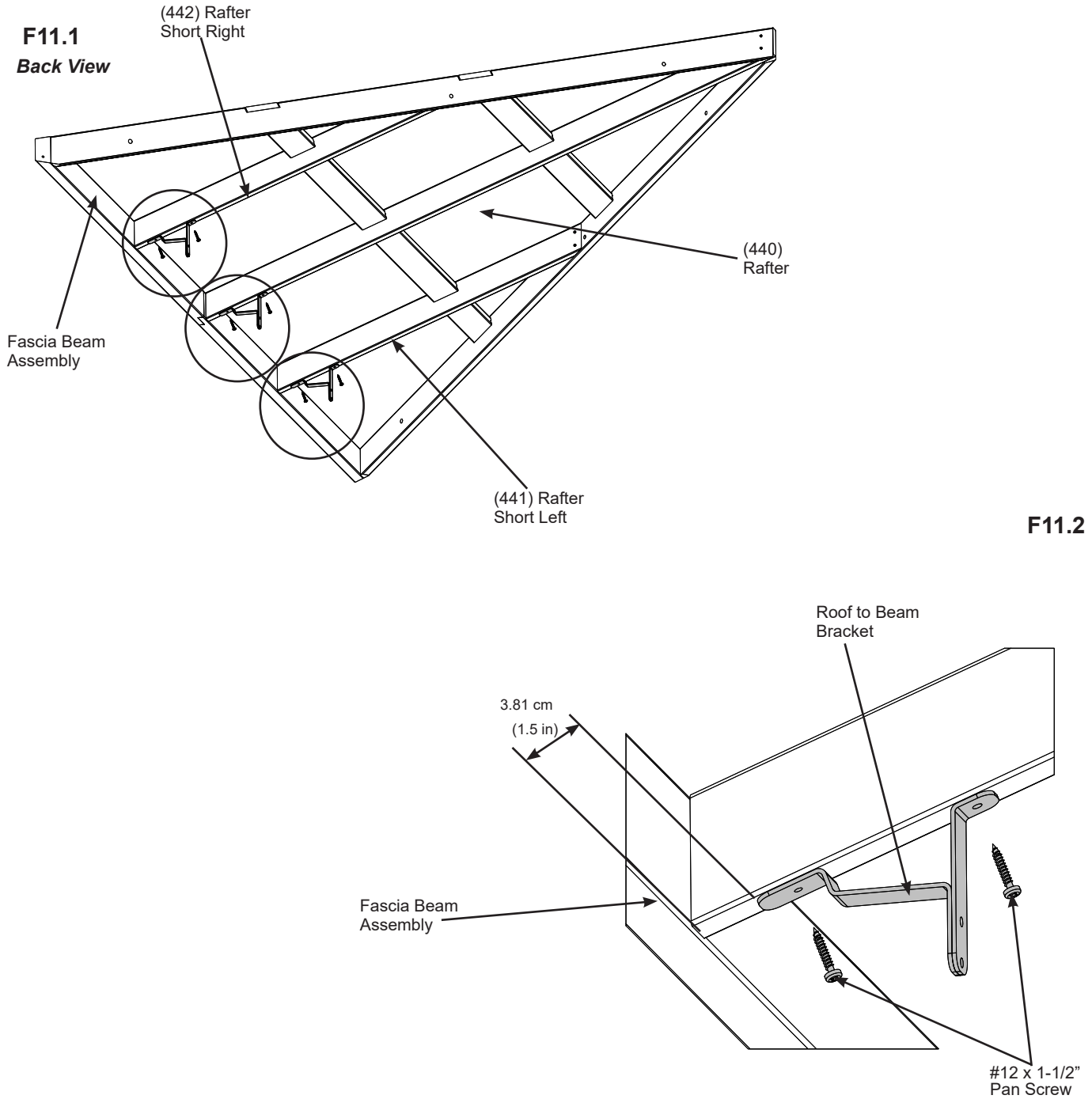

**Components**

3 x Roof to Beam Bracket

**Hardware**

6 x #12 x 1-1/2" Pan Screw Yellow

# Step 12: Large Roof Rafter Assembly Part 1

**A:** On each side of one (434) Top place one (440) Rafter so the tops and edges are flush then attach with two #8 x 2-1/2" Wood Screws per side. (F12.1 and F12.2)

**B:** Place Large Fascia Beam Assembly from Step 9B on the bottom of (440) Rafters so the sides are flush and holes are centered on the (440) Rafters then attach with two #8 x 2-1/4" Wood Screws per (440) Rafter. (F12.1 and F12.3)

**C:** Repeat Steps A and B to make a second Large Roof Rafter Assembly.

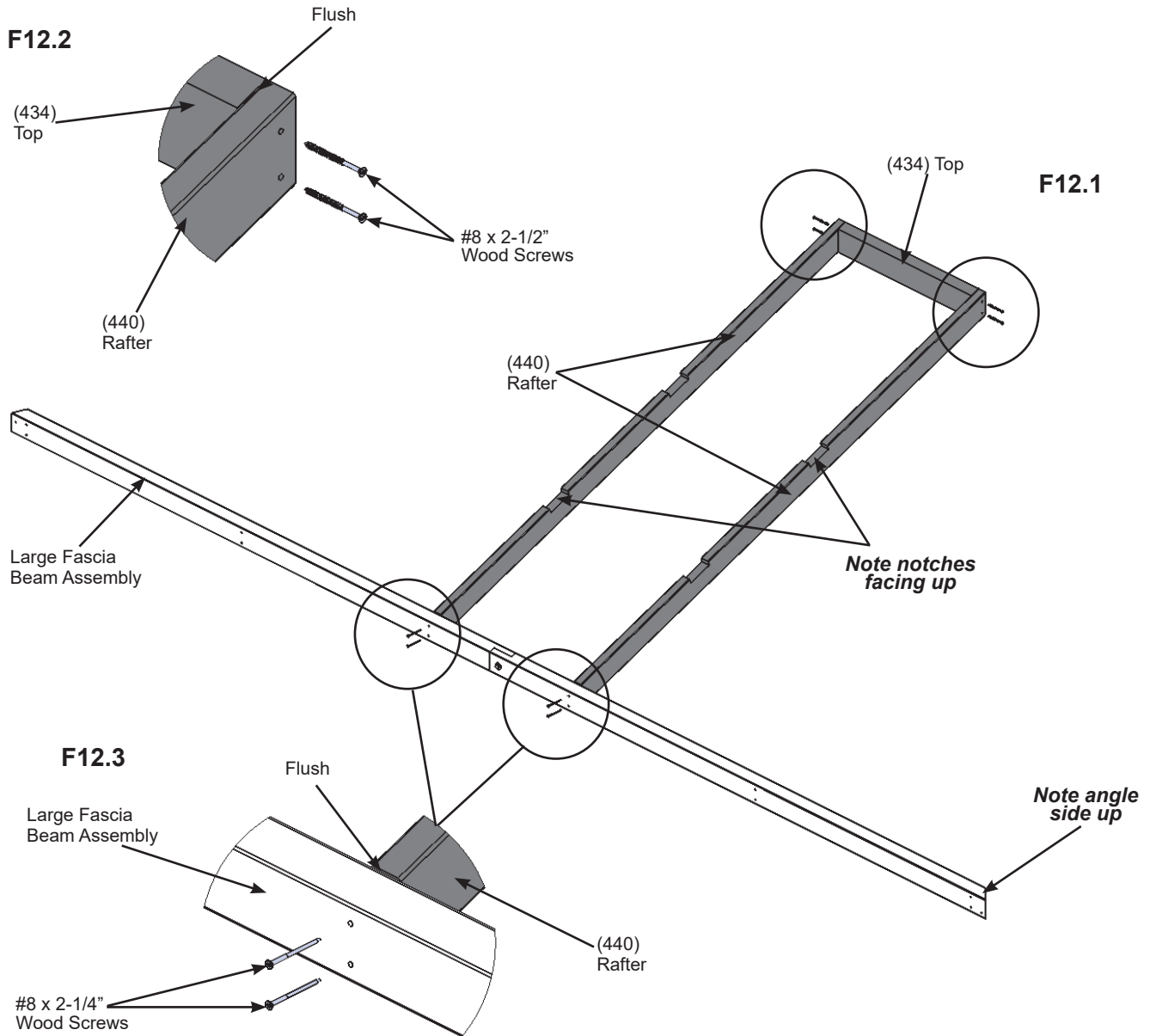

### Wood Parts

- 4 x (440) Rafter
- 2 x (434) Top

### Hardware

- 8 x #8 x 2-1/4" Wood Screw
- 8 x #8 x 2-1/2" Wood Screw

# Step 12: Large Roof Rafter Assembly Part 2

**D:** Beside each (440) Rafter place one (2342) Rafter Corner Left and one (2343) Rafter Corner Right so the tops and edges are flush and the bottom edges are flush to Large Fascia Beam Assembly then attach with two #8 x 2-1/4" Wood Screws to the top and bottom of the rafters per side. (F12.4, F12.5 and F12.6)

**E:** Repeat Step D for the second Large Roof Rafter Assembly.

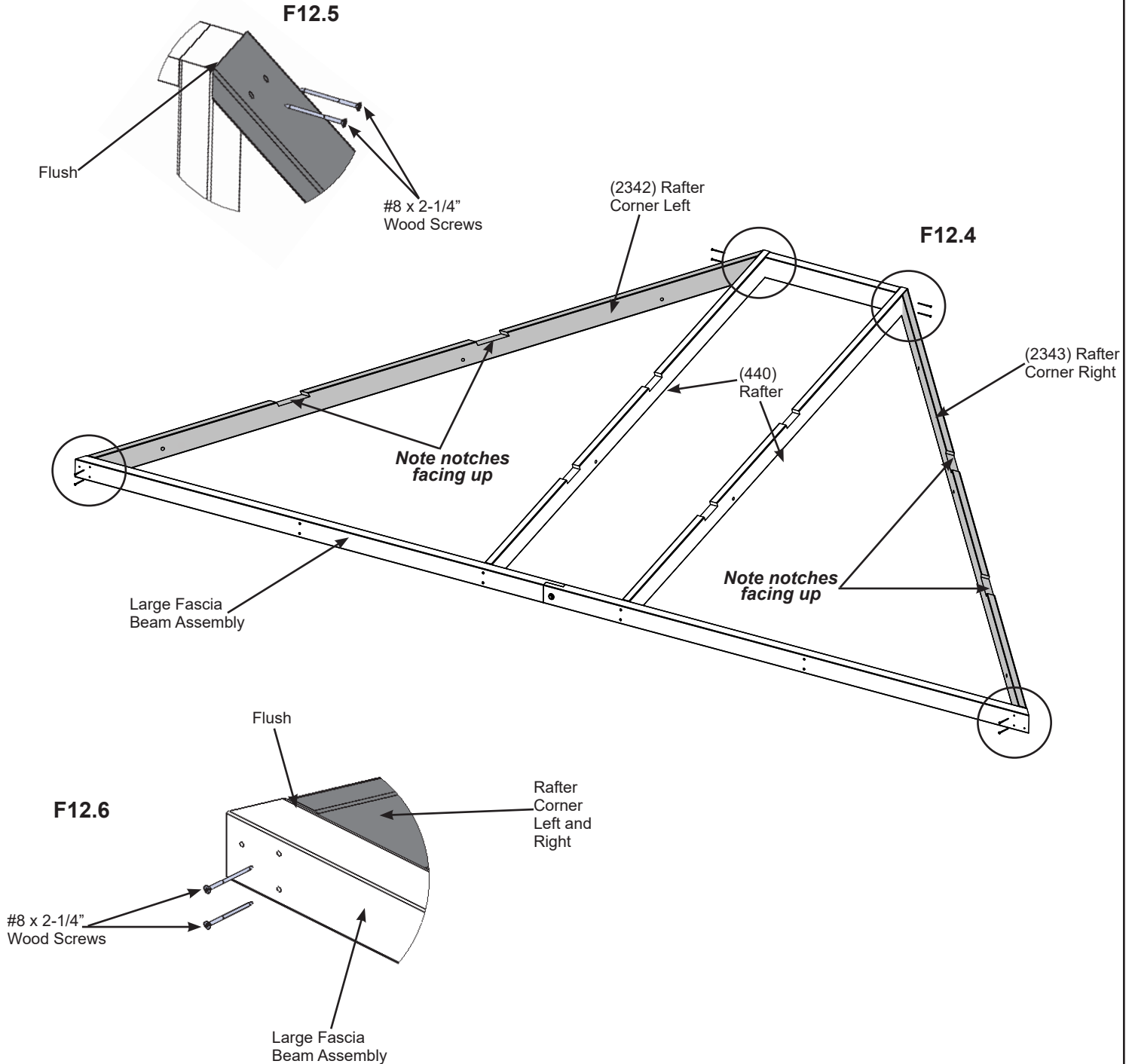

### Wood Parts

- 2 x (2342) Rafter Corner Left
- 2 x (2343) Rafter Corner Right

### Hardware

- 16 x #8 x 2-1/4" Wood Screw

# Step 12: Large Roof Rafter Assembly Part 3

**F:** Place one (430) Strap Short - Large Roof in the notches of (2342) Rafter Corner Left, (2343) Rafter Corner Right and both (440) Rafters so the ends do not overhang the outside edges of the outside boards then attach with eight #8 x 1-1/2" Wood Screws. (F12.7)

**G:** Place one (431) Strap Left - Large Roof in the notches of (2342) Rafter Corner Left and one (440) Rafter and one (432) Strap Right - Large Roof in the notches of (2343) Rafter Corner Right and the other (440) Rafter so the ends do not overhang the outside edges of the outside boards. Boards are tight in the center. Do not attach yet. (F12.7)

**H:** Place one (442) Rafter Short Right in the notches of (432) Strap Right - Large Roof and one (441) Rafter Short Left in the notches of (431) Strap Left - Large Roof and attach to (2342) Rafter Corner Left and (2343) Rafter Corner Right with two #8 x 1-1/2" Wood Screws per board and to Large Fascia Beam Assembly with two #8 x 2-1/4" Wood Screws per board. (F12.7)

**I:** Attach (431) Strap Left - Large Roof and (432) Strap Right - Large Roof to (2342) Rafter Corner Left, (2343) Rafter Corner Right and (440) Rafter with six #8 x 1-1/2" Wood Screws per board. (F12.7)

## F12.7

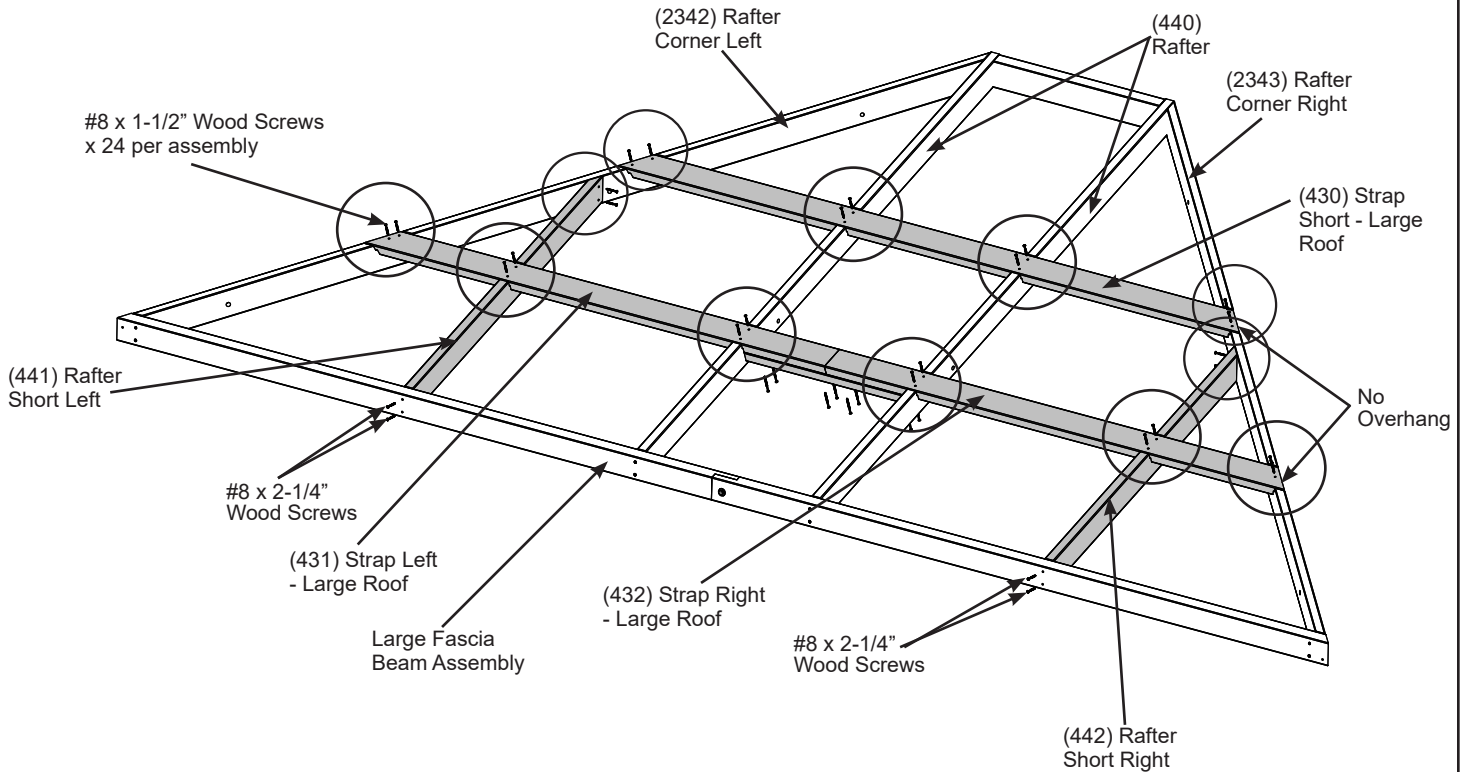

### Wood Parts

- 2 x (430) Strap Short - Large Roof
- 2 x (431) Strap Left - Large Roof
- 2 x (432) Strap Right - Large Roof
- 2 x (442) Rafter Short Right
- 2 x (441) Rafter Short Left

### Hardware

- 48 x #8 x 1-1/2" Wood Screw
- 8 x #8 x 2-1/4" Wood Screw

# Step 12: Large Roof Rafter Assembly Part 4

**J:** Turn Large Roof Rafter Assembly over then attach one (433) Strap Brace to (431) Strap Left - Large Roof and (432) Strap Right - Large Roof with eight #8 x 2-1/4" Wood Screws. Edges are flush. (F12.8 and F12.9)

**K:** Complete Steps F - J for both Large Roof Rafter Assemblies.

**F12.8**  
*Front View*

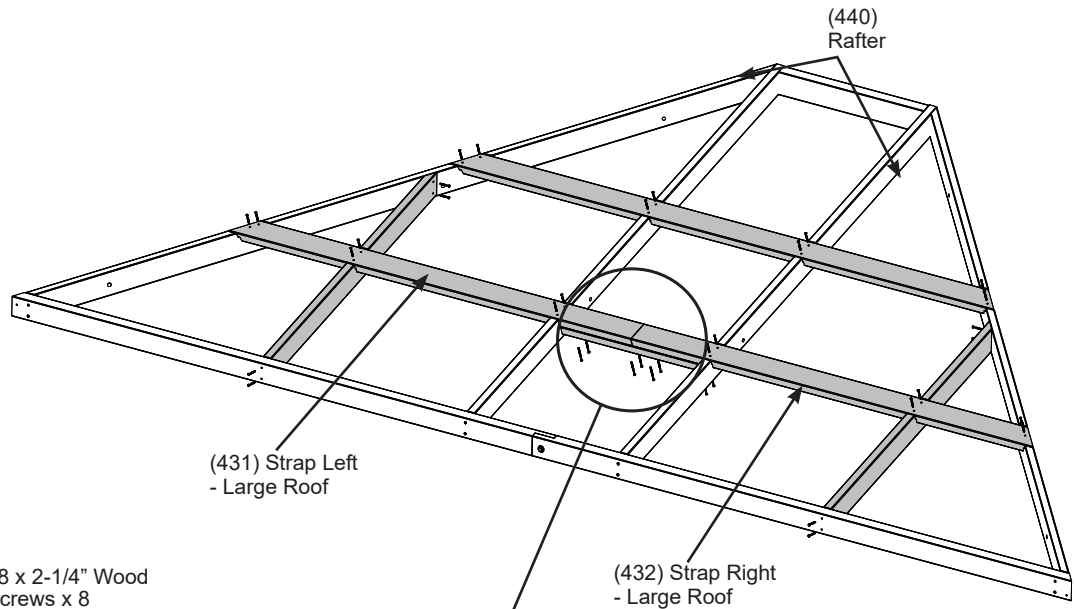

**F12.9**  
*Back View*

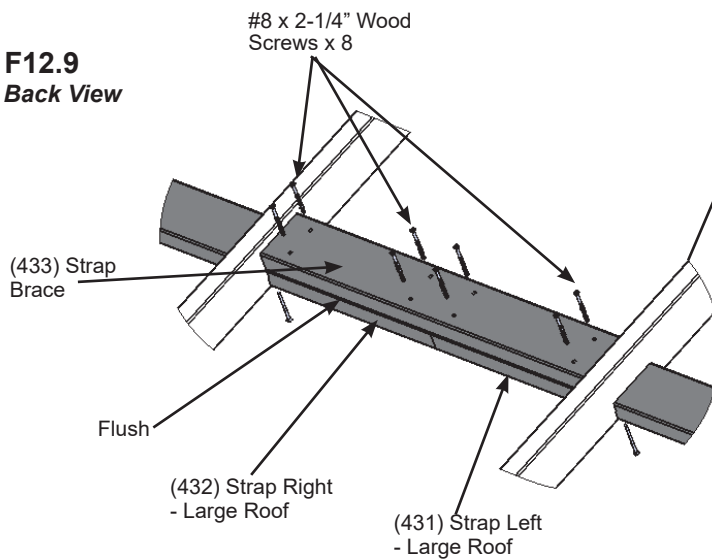

### Wood Parts

2 x (433) Strap Brace

### Hardware

16 x #8 x 2-1/4" Wood Screw

# Step 13: Attach Roof to Beam Brackets - Large Roof Rafter Assemblies



**A:** On the Back of both Large Roof Rafter Assemblies, centered and 3.81 cm (1.5 in) from the bottom of (442) Rafter Short Right, (441) Rafter Short Left and both (440) Rafter attach one Roof to Beam Bracket per board with two #12 x 1-1/2" Pan Screws per bracket. (F13.1 and F13.2)

**F13.1**  
*Back View*

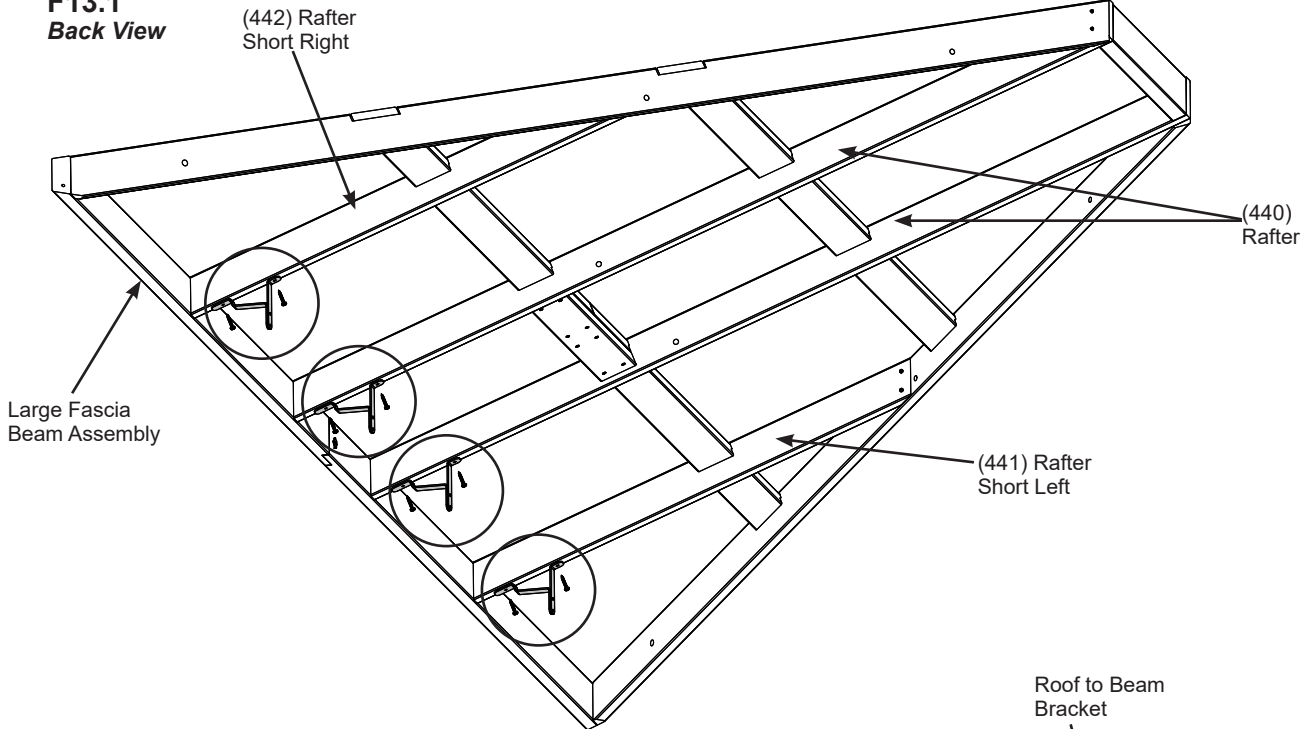

**F13.2**

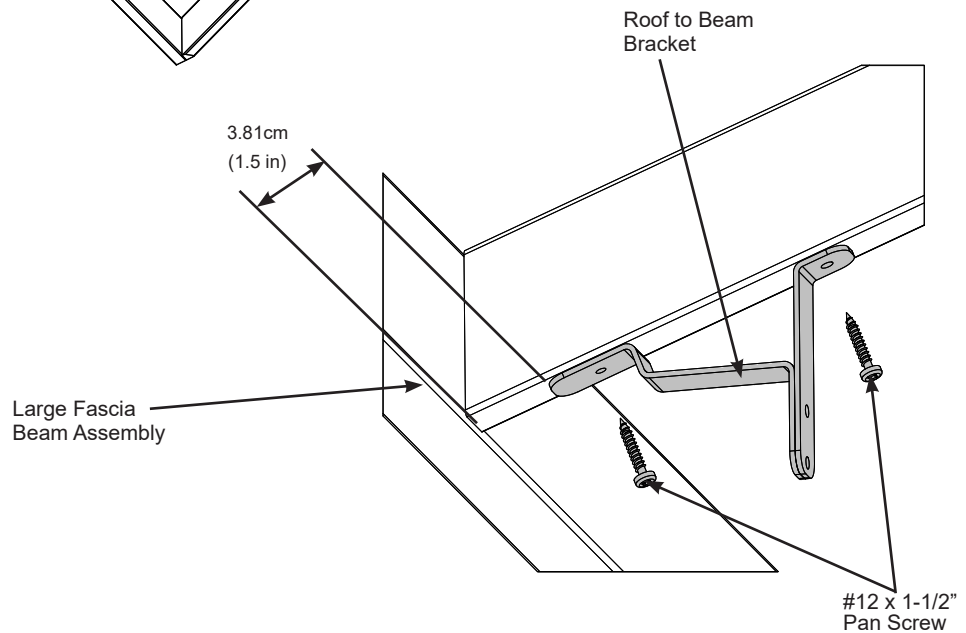

**Components**

8 x Roof to Beam Bracket

**Hardware**

16 x #12 x 1-1/2" Pan Screw Yellow

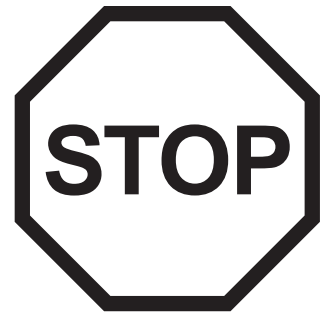
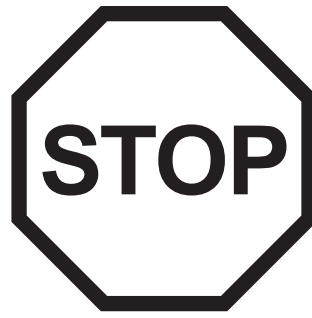
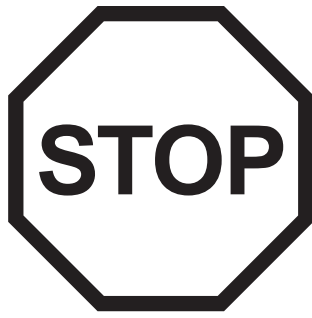
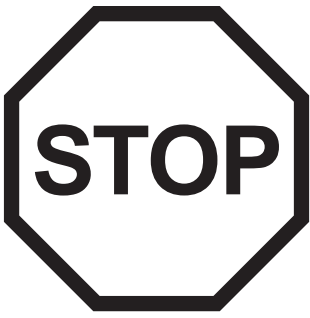

# INSTALLING ROOFING MATERIAL

---

## CAUTION!

Roofing material may have sharp edges! Wear gloves!

## HANDLE WITH CARE!

Place roofing material on a non-abrasive surface before assembly as it can bend, dent and scratch easily.

**WARNING – DO NOT OVER TIGHTEN ROOFING SCREWS!  
Over tightening screws will cause roofing material to crush.**

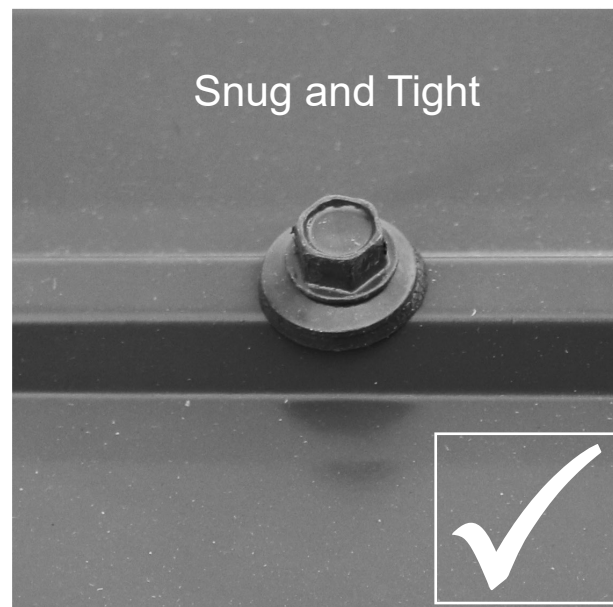

The roofing screws can easily crush the Roof Panels and Roof Edges when using a power drill. We recommend hand tightening the roofing screws so that they sit snug and tight to the roofing material.

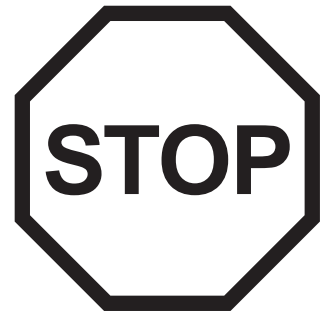
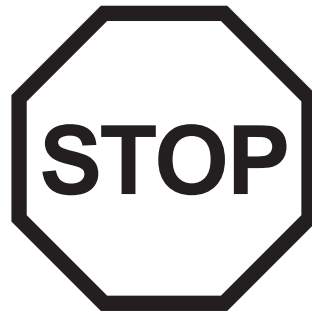
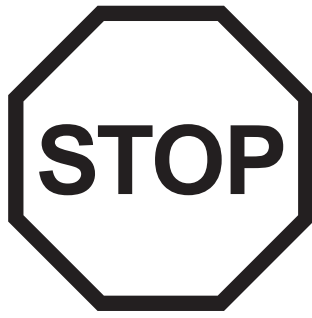
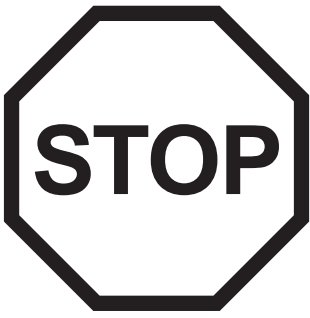

# INSTALLING ROOFING MATERIAL

## CAUTION!

Roofing material may have sharp edges! Wear gloves!

**BE SURE TO REMOVE ALL PLASTIC COVERING, ON BOTH SIDES OF THE ALUMINUM PANELS AND TRIM, DIRECTLY BEFORE INSTALLING EACH PIECE.**

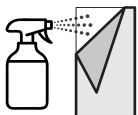
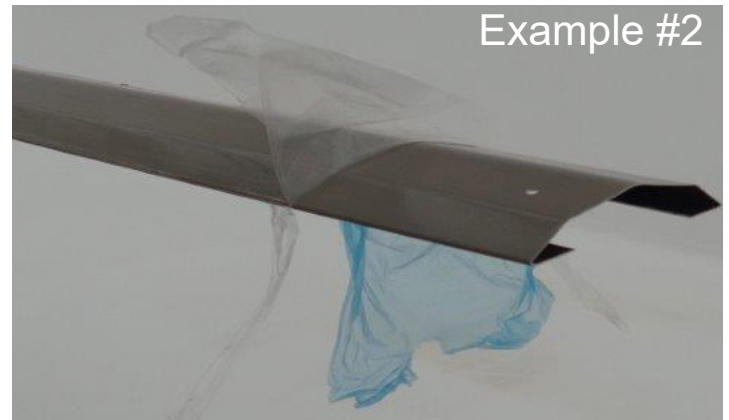
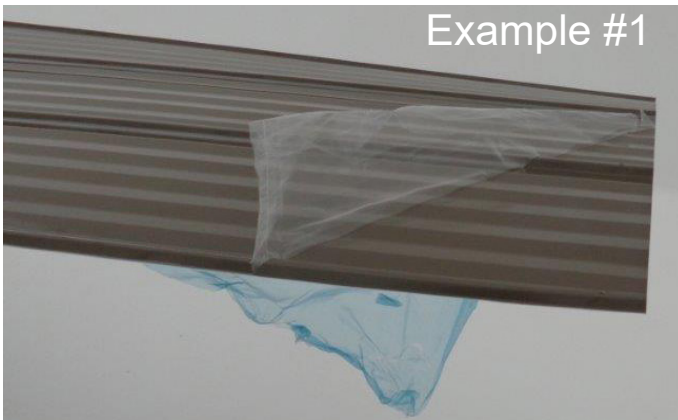

**NOTE: If film is difficult to remove, spray a mixture of dish soap and water continuously between the film and the panel and peel back slowly.**

# Step 14: Attach Roof Panels - Small Roof

## Part 1

**A:** Place one Long Panel Left on the front of one Small Roof Rafter Assembly so it is flush to the side of (2342) Rafter Corner Left and a slight overhang at the bottom of the Fascia Beam Assembly. Holes should line up with (440) Rafter. (F14.1 and F14.2)

**B:** Place one Long Panel Right on Small Roof Rafter Assembly so it overlaps the Long Panel Left and it is flush to the side of (2343) Rafter Corner Right and a slight overhang at the bottom of the Fascia Beam Assembly. (F14.1 and F14.2)

**C:** Attach both Left and Right Long Panels to Small Roof Rafter Assembly with four #8 x 1" Roofing Screws in locations shown in F14.1. Be sure not to overtighten screws.

**D:** Repeat Steps A - C for both Small Roof Rafter Assemblies.

**DO NOT overtighten screws, could cause damage to roofing material**

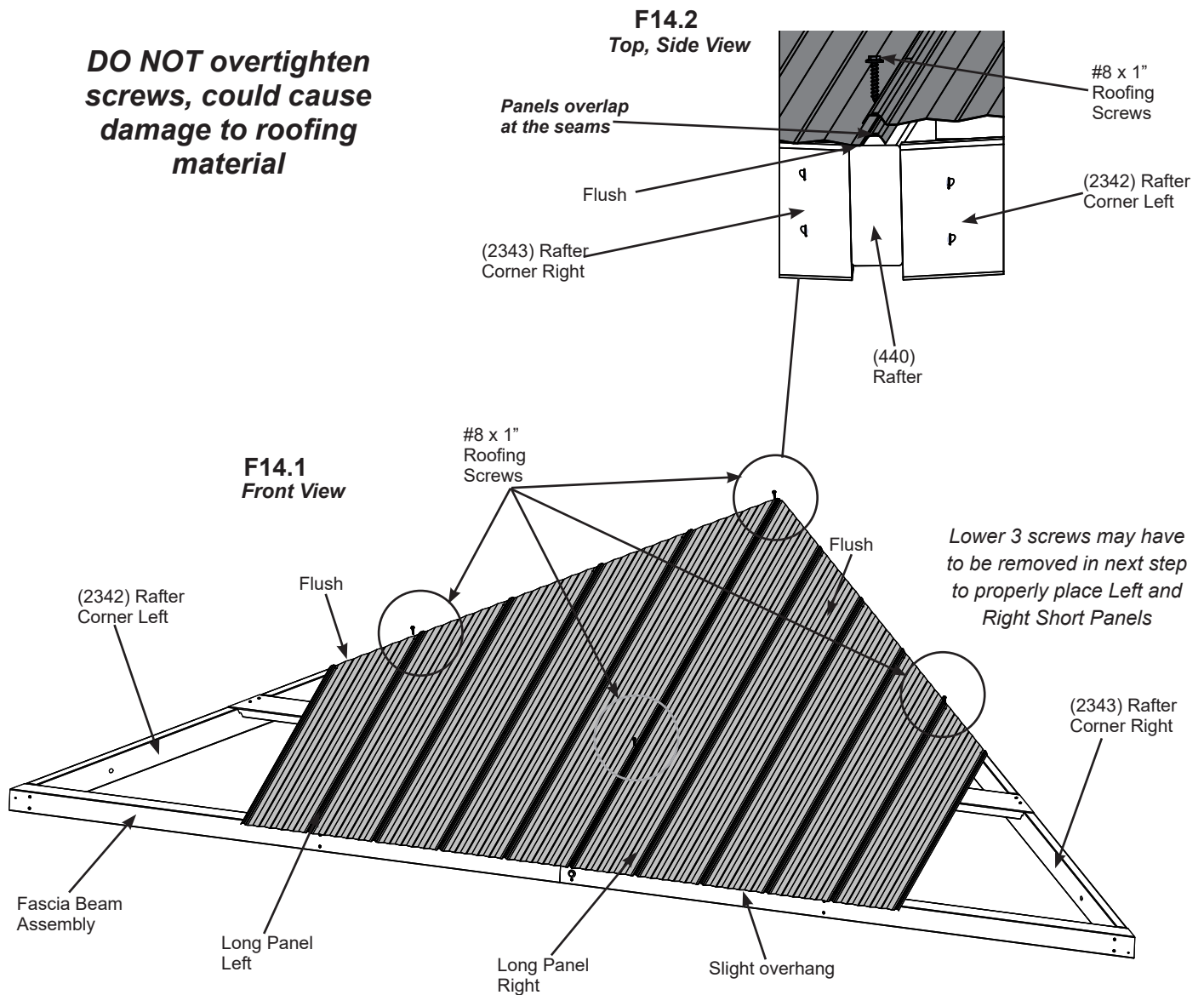

### Roof Parts

2 x Long Panel Left  
2 x Long Panel Right

### Hardware

8 x #8 x 1" Roofing Screw

# Step 14: Attach Roof Panels - Small Roof Part 2

**E:** Place one Short Panel Left on Small Roof Rafter Assembly so it overlaps the Long Panel Left and it is flush to the sides of (2342) Rafter Corner Left and a slight overhang at the bottom of the Fascia Beam Assembly. (F14.3 and F14.4)

**F:** Place one Short Panel Right on Small Roof Rafter Assembly so it overlaps the Long Panel Right and it is flush to the side of (2343) Rafter Corner Right and a slight overhang at the bottom of the Fascia Beam Assembly. There should be no overhanging at the corners. (F14.3 and F14.4)

**G:** Attach all panels to Small Roof Rafter Assembly with 33 #8 x 1" Roofing Screws in locations shown in F14.3. Do not place any screws along the bottom row. Be sure not to overtighten screws.

**H:** Repeat Steps E - G for both Small Roof Rafter Assemblies.

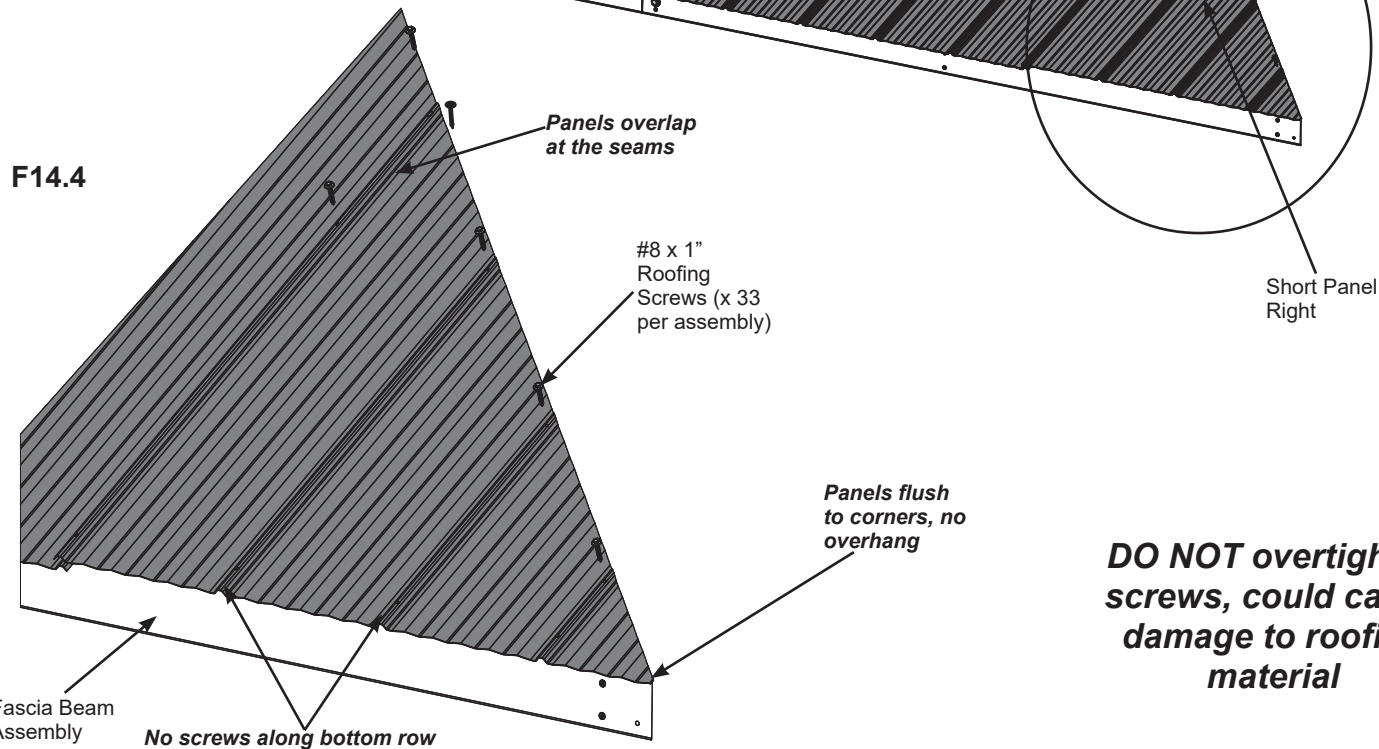
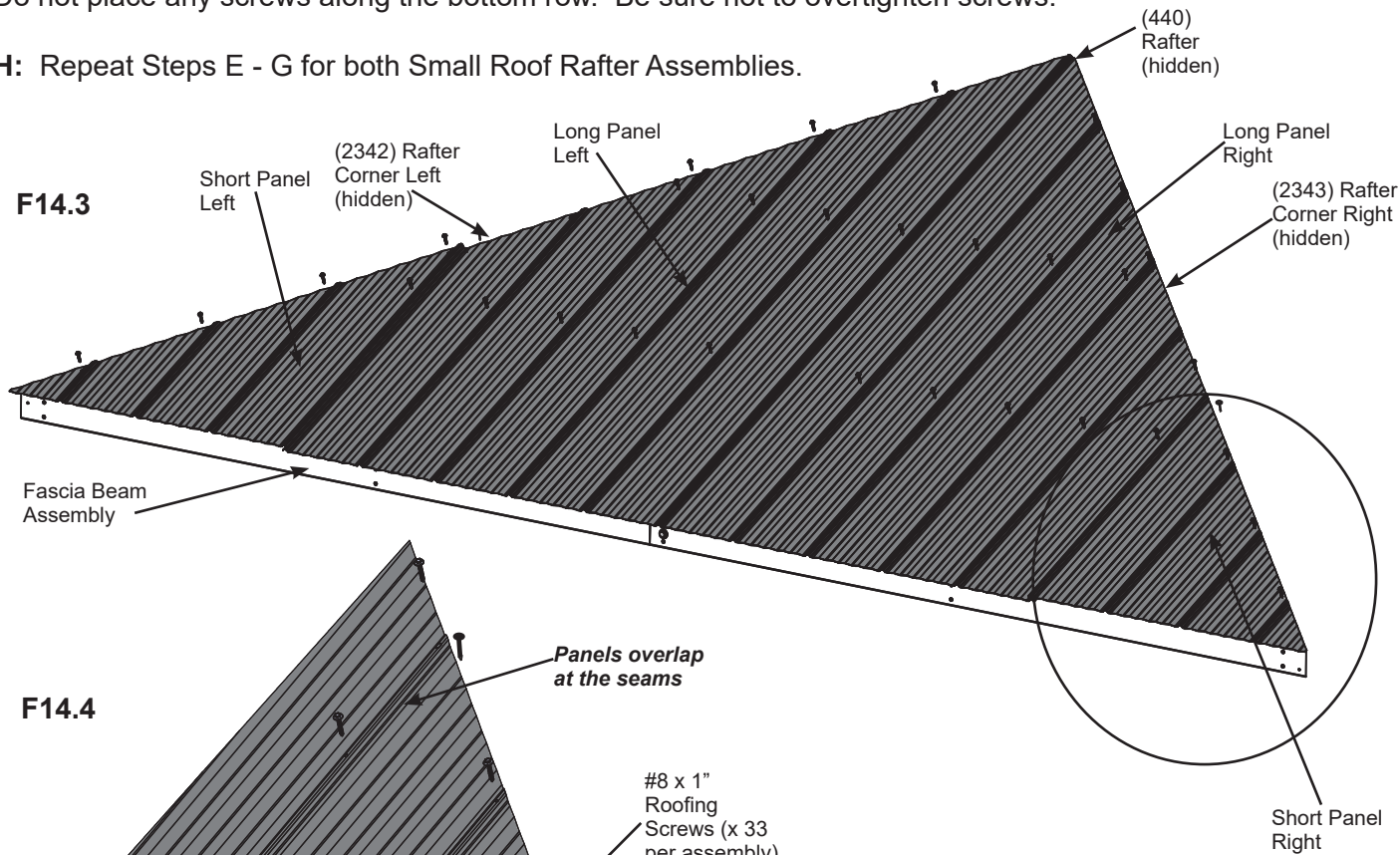

**DO NOT overtighten screws, could cause damage to roofing material**

## Roof Parts

- 2 x Short Panel Left
- 2 x Short Panel Right

## Hardware

- 66 x #8 x 1" Roofing Screw

# Step 15: Attach Ridge Clips and Roof Edges - Small Roof



**A:** Place one Roof Edge Left 72.2 and one Roof Edge Right 72.2 on the bottom of each Small Roof Rafter Assembly so the ends are flush with the outside ends of the Fascia Beam Assembly and meet tight in the center. Attach both Roof Edges with 17 #8 x 1" Roofing Screws per Small Roof Rafter assembly. (F15.1 and F15.2)

**B:** Place one Weather Seal on the inside of each Ridge Clip 102.5 then place one Ridge Clip 102.5 on each side of each Small Roof Rafter Assembly so they cover the panels and bottom edge is 6.99cm (2.75 in) up from the bottom of the Corner Rafters then attach with five #7 x 3/4" Wood Screws per Ridge Clip 102.5. (F15.1, F15.3 and F15.4)

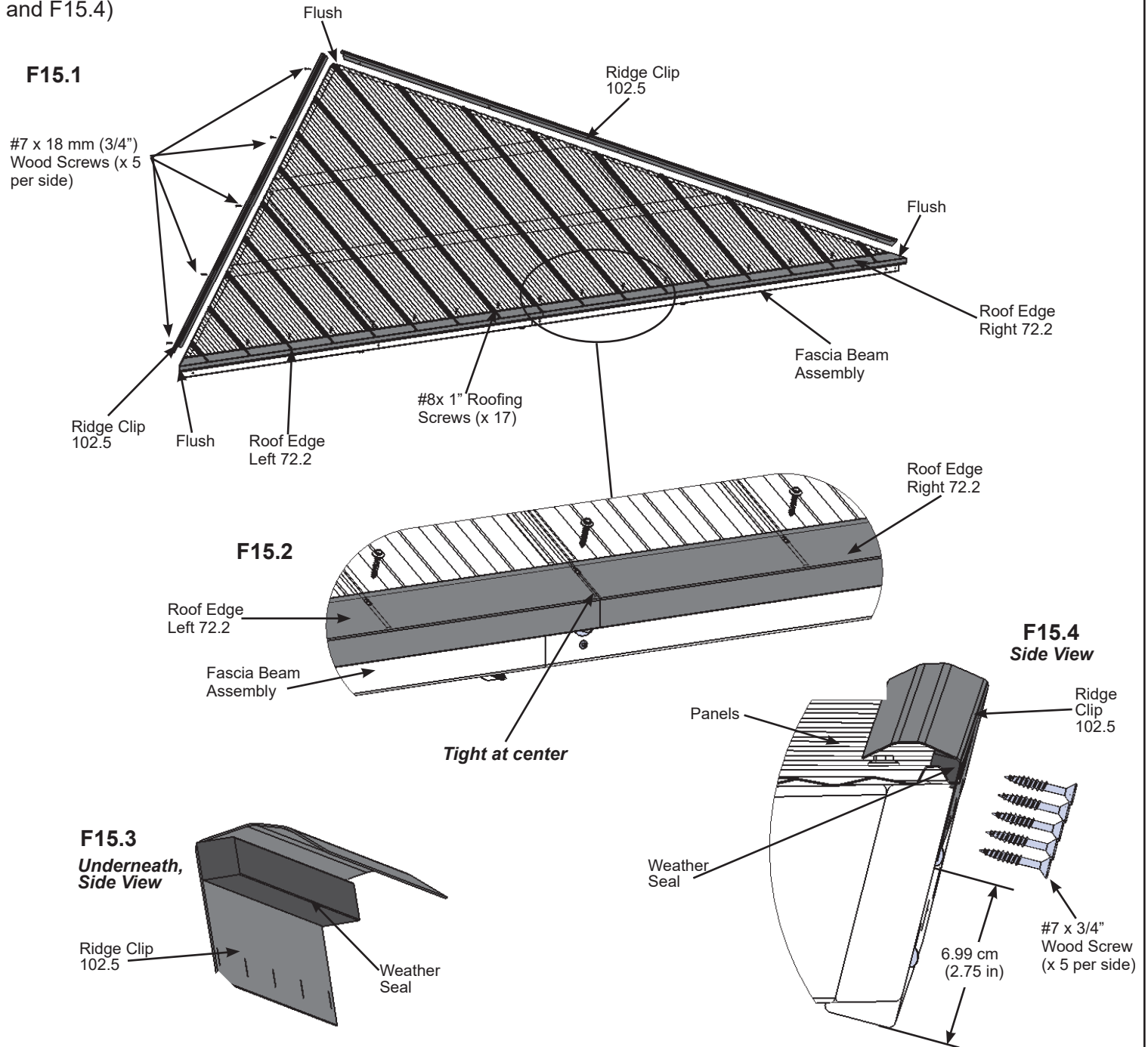

**Components:**

- 2 x Roof Edge Left 72.2
- 2 x Roof Edge Right 72.2
- 4 x Ridge Clip 102.5
- 4 x Weather Seal

**Hardware**

- 34 x #8 x 1" Roofing Screw
- 20 x #7 x 3/4" Wood Screw

# Step 16: Attach Roof Panels - Large Roof Part 1

**A:** Place one Middle Panel on the front of one Large Roof Rafter Assembly so it slightly overhangs the top of (434) Top and an overhang at the bottom of the Large Fascia Beam Assembly. Holes should line up with (440) Rafter and (430), (431) and (432) Straps. (F16.1)

**B:** Place one Long Panel Left and one Long Panel Right on each side of Middle Panel so they overlap the Middle Panel and are flush to the sides of (2342) Rafter Corner Left and (2343) Rafter Corner Right and an overhang at the bottom of the Large Fascia Beam Assembly. Attach with two #8 x 1" Roofing Screws per panel in the places shown below. Be sure not to overtighten screws. (F16.2)

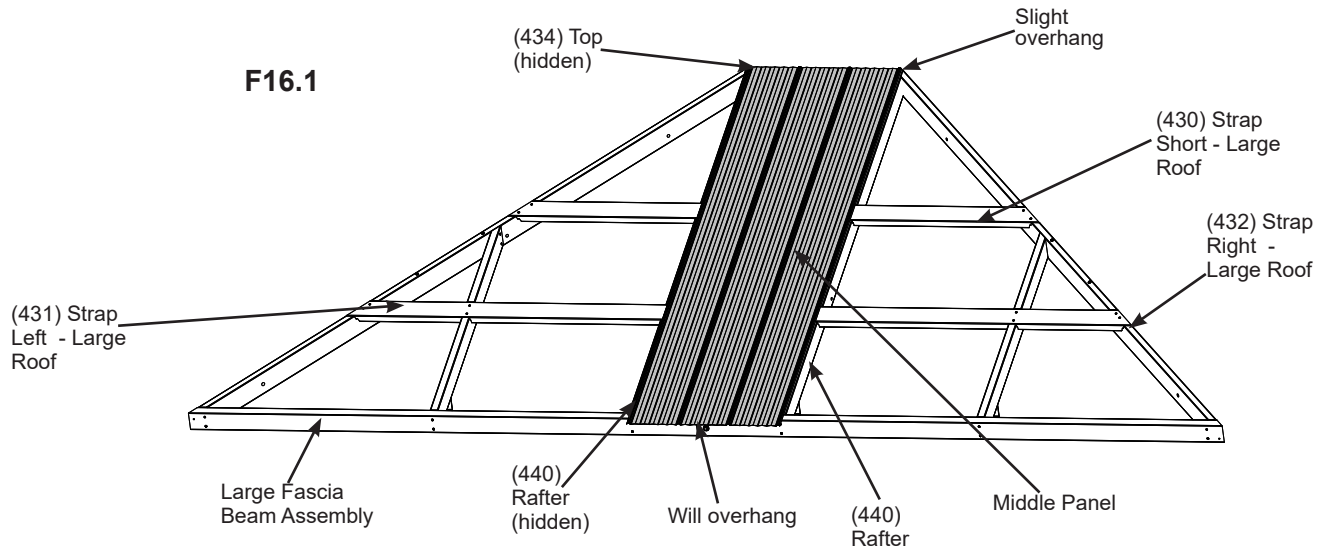

**DO NOT overtighten screws, could cause damage to roofing material**

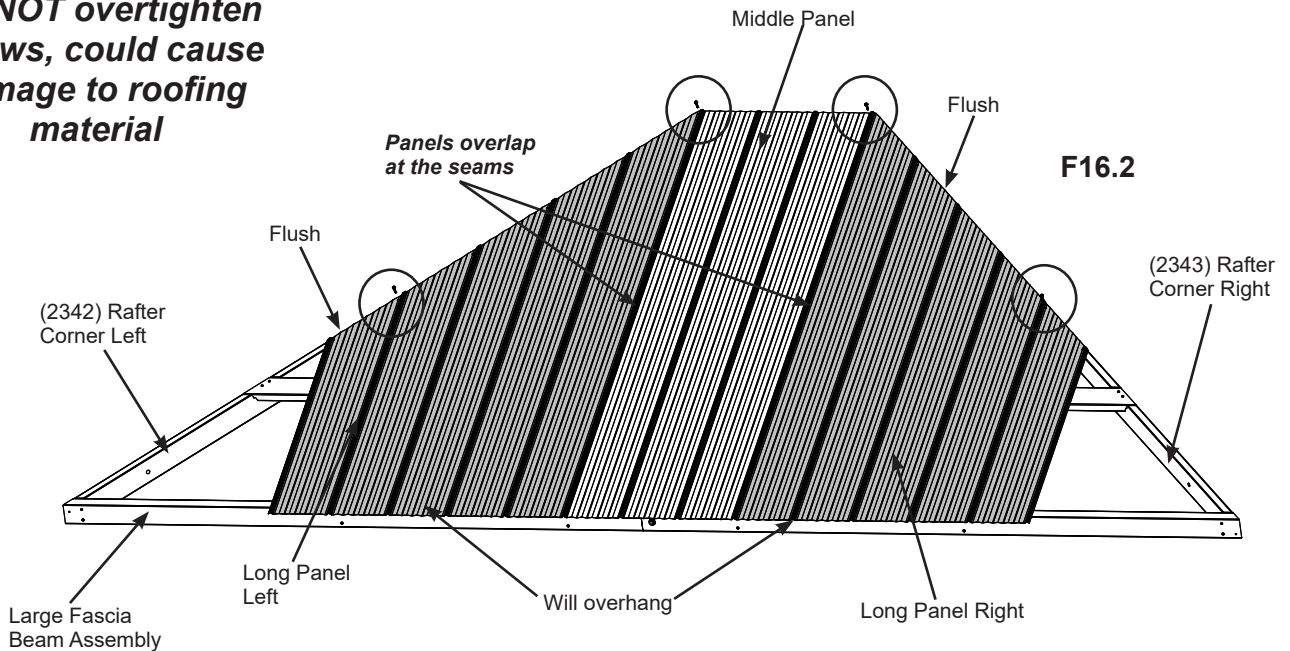

### Roof Parts

- 2 x Middle Panel
- 2 x Long Panel Left
- 2 x Long Panel Right

### Hardware

- 8 x #8 x 1" Roofing Screw

# Step 16: Attach Roof Panels - Large Roof Part 2

**C:** Place one Short Panel Left so it overlaps the Long Panel Left and it is flush to the sides of (2342) Rafter Corner Left and one Short Panel Right so it overlaps the Long Panel Right and it is flush to the side of (2343) Rafter Corner Right. There will be a slight overhang at the bottom of the Large Fascia Beam Assembly. There should be no overhang at the corners. (F16.3 and F16.4)

**D:** Make sure all panels fit properly then attach with 42 #8 x 1" Roofing Screws. Be sure not to overtighten screws. (F16.3 and F16.4)

**Notice there are no screws along the bottom row.**

**E:** Repeat Steps A - D for both Large Roof Rafter Assemblies.

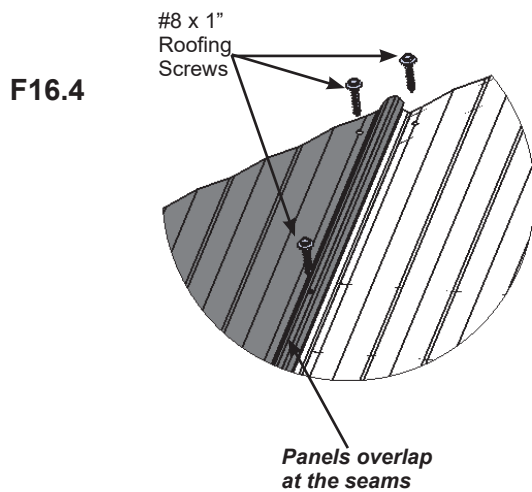
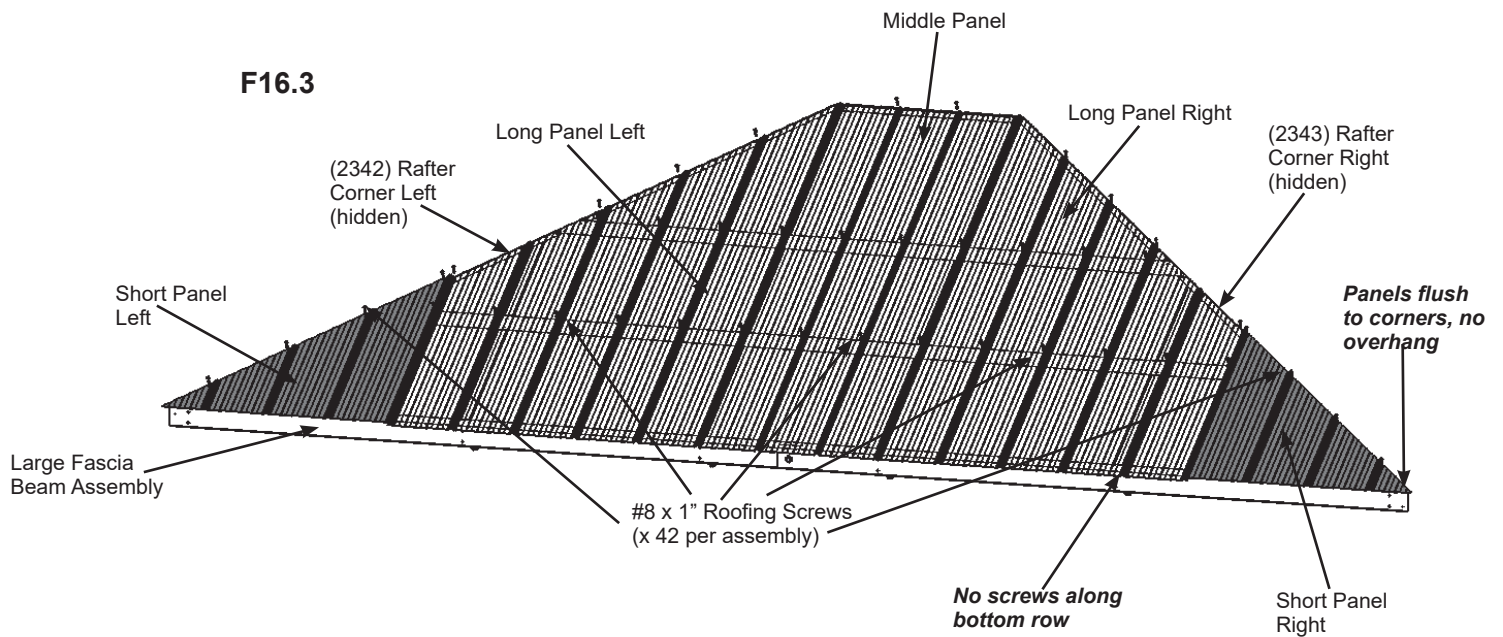

**DO NOT overtighten screws, could cause damage to roofing material**

## Roof Parts

2 x Short Panel Left  
2 x Short Panel Right

## Hardware

84 x #8 x 1" Roofing Screw

# Step 16: Attach Roof Panels - Large Roof Part 3

**F:** On one Large Roof Rafter Assembly place one (463) Spacer Top flush to the outside edges and centered on (434) Top then attach with three #8 x 2-1/4" Wood Screws. (F16.5 and F16.6)

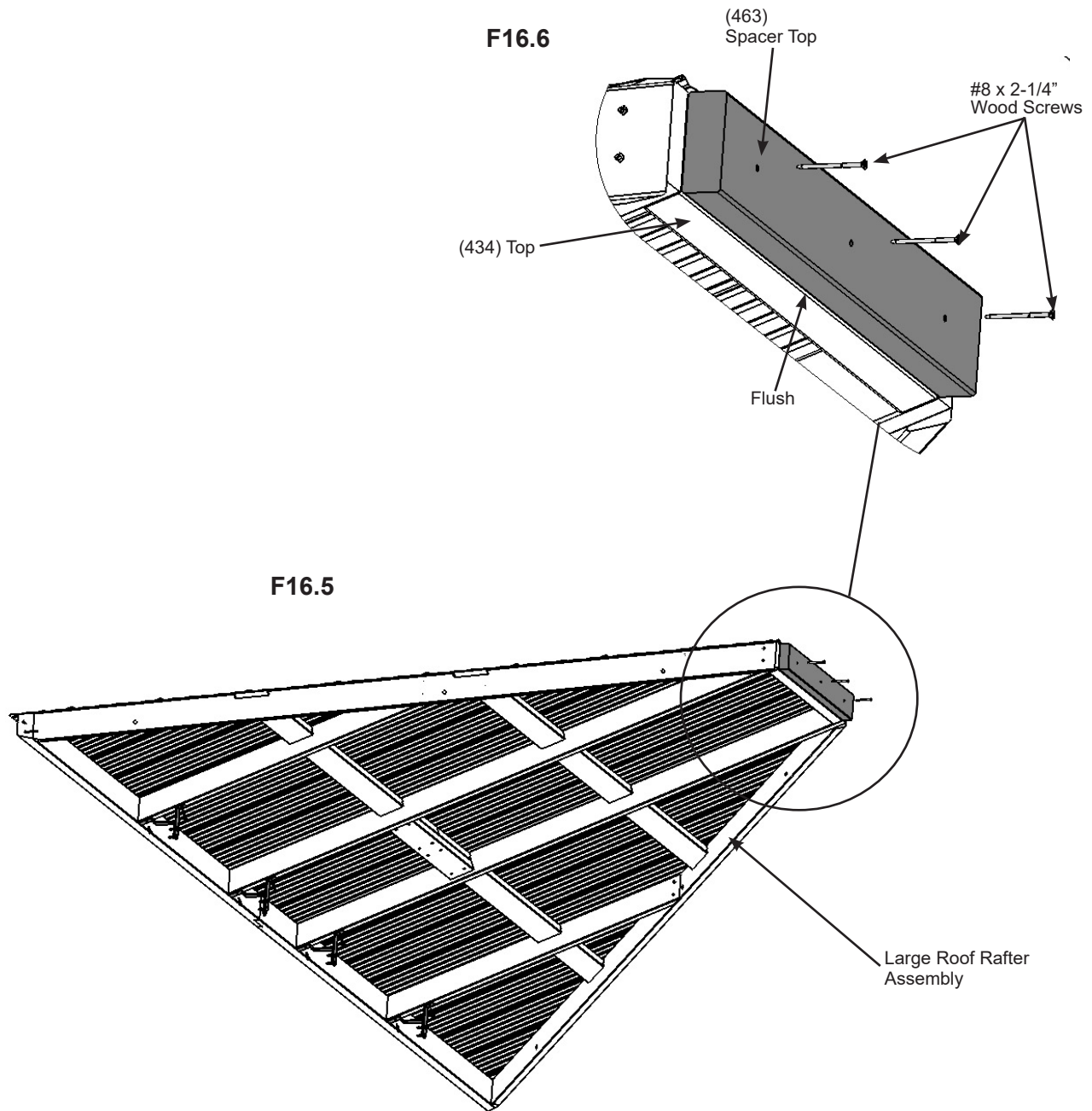

## Wood Parts

1 x (463) Spacer Top

## Hardware

3 x #8 x 2-1/4" Wood Screws

# Step 17: Attach Ridge Clips and Roof Edges - Large Roof



**A:** Place one Roof Edge Left 72.2 and one Roof Edge Right 96.2 on the bottom of each Large Roof Rafter Assembly so the ends are flush with the outside ends of the Large Fascia Beam Assembly and meet tight in the center. Attach both Roof Edges with 20 #8 x 1" Roofing Screws per Large Roof Rafter assembly. (F17.1 and F17.2)

**B:** Place one Weather Seal on the inside of each Ridge Clip 102.5 then place one Ridge Clip 102.5 on each side of each Large Roof Rafter Assembly so they cover the panels and bottom edge is 6.99 cm (2.75 in) up from the bottom of the Corner Rafters then attach with five #7 x 3/4" Wood Screws per Ridge Clip 102.5. (F17.1, F17.3 and F17.4)

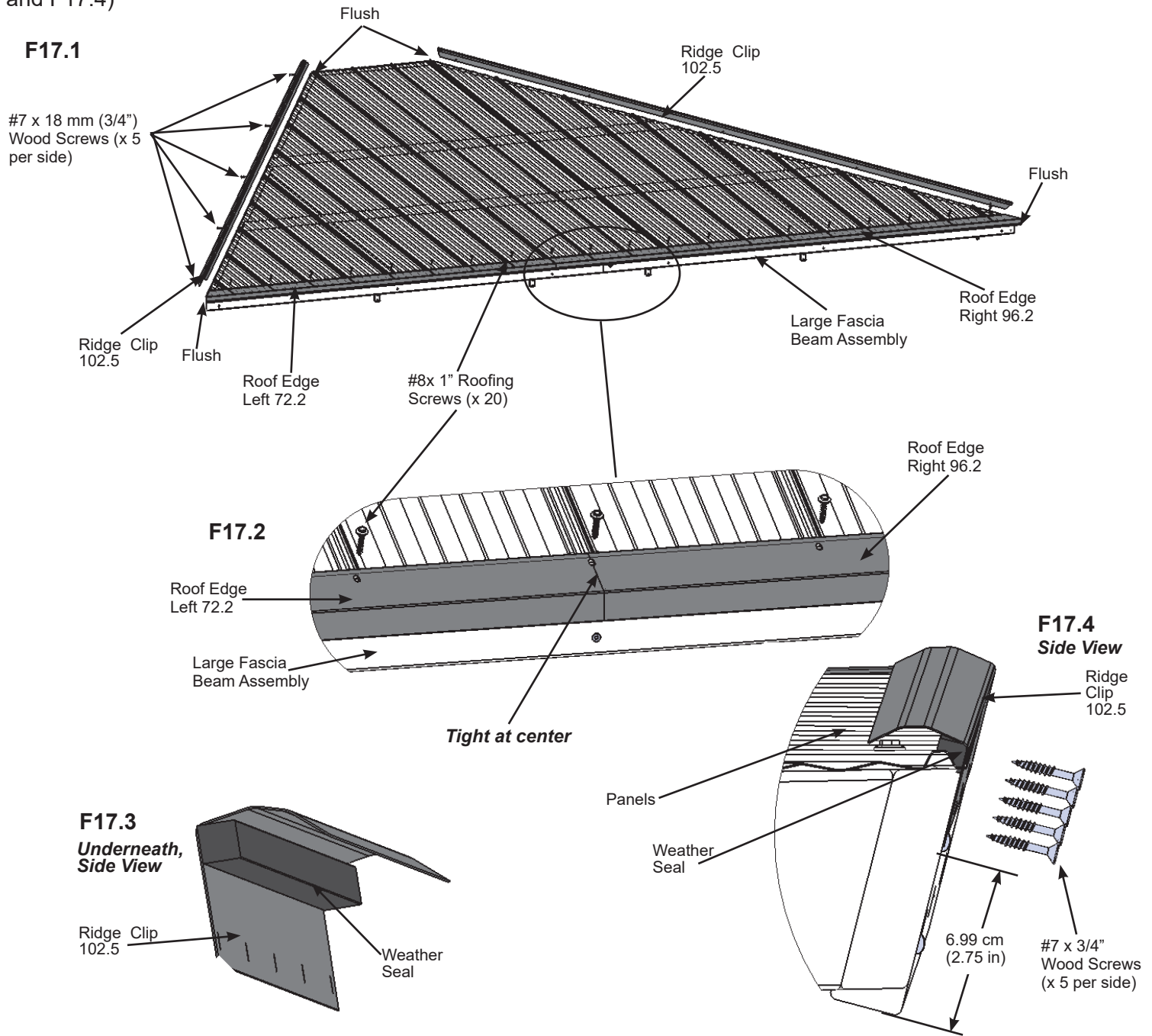

**Components:**

- 2 x Roof Edge Left 72.2
- 2 x Roof Edge Right 96.2
- 4 x Ridge Clip 102.5
- 4 x Weather Seal

**Hardware**

- 40 x #8 x 1" Roofing Screw
- 20 x #7 x 3/4" Wood Screw

# Step 18: Attach Roof Panels to Frame Part 1

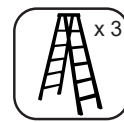

**A:** With all four assemblers place Large Roof Panel Assembly with Roof to Beam Brackets just in front of the posts then raise it up so it is over Long Beam Assembly, taking care not to drag the panel on the beams. Make sure the Rafter Corners sit in Post to Rafter Connectors. (F18.1, F18.2 and F18.3)

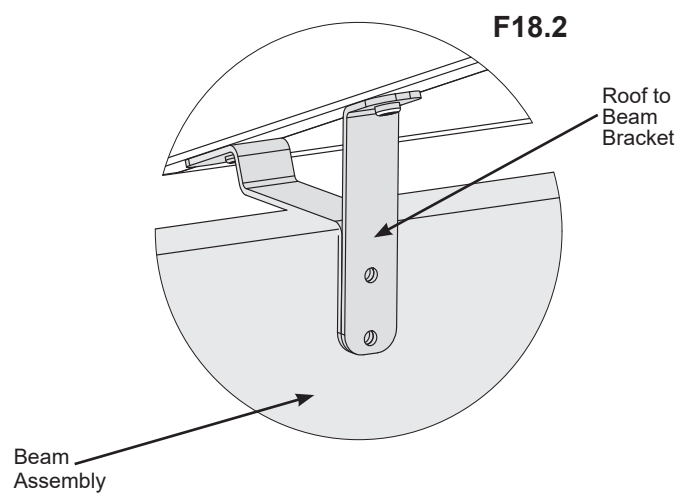
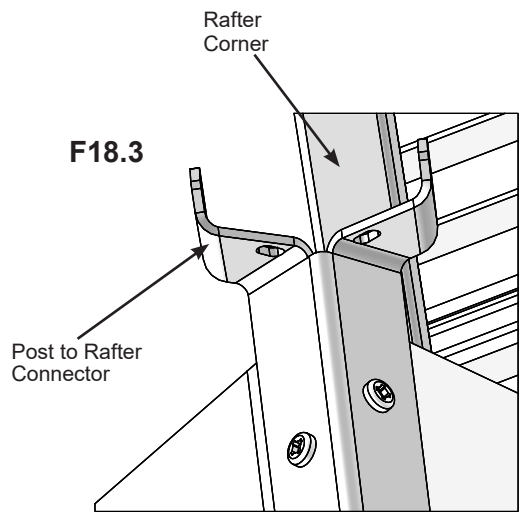
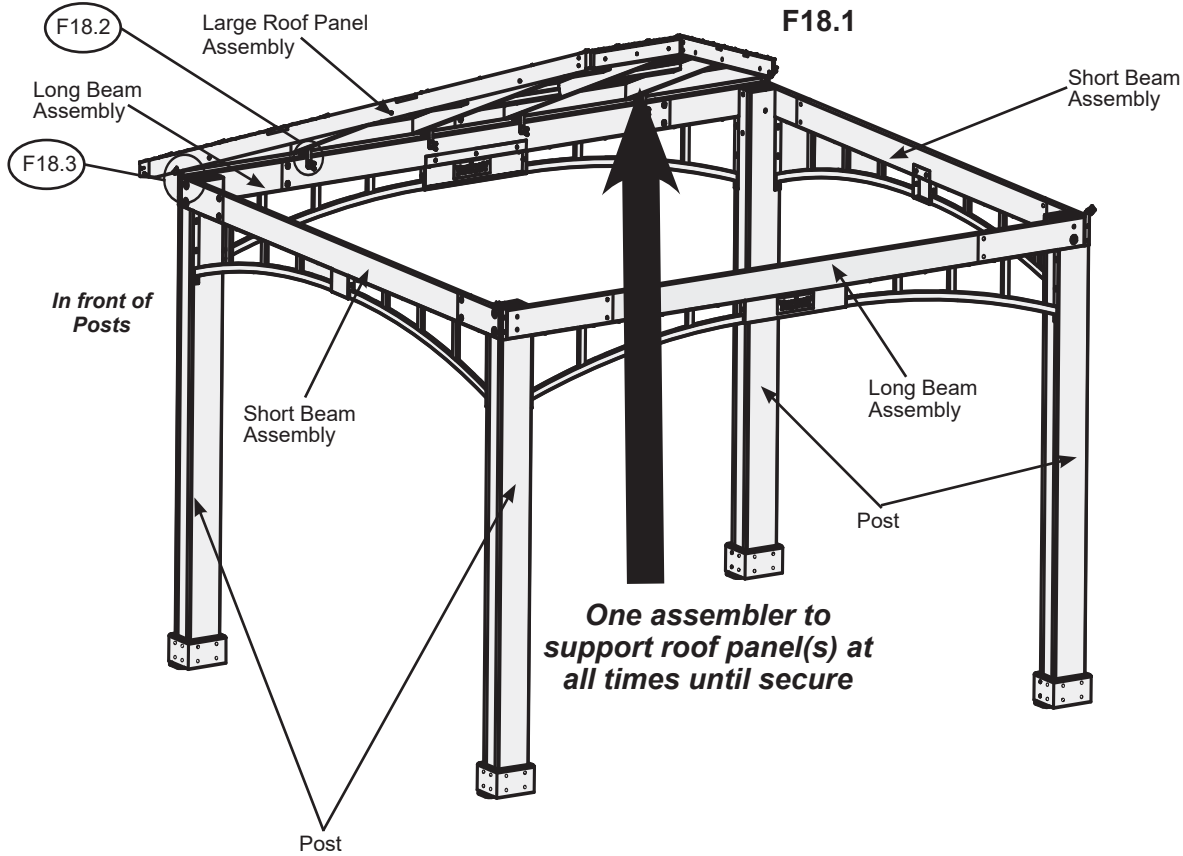

# Step 18: Attach Roof Panels to Frame Part 2



**B:** Lift a Small Roof Panel Assembly with Roof to Beam Brackets over Short Beam Assembly taking care not to drag the panel on the beams. Make sure the Rafter Corners are flush with each other and sit in Rafter to Post Connectors.. **One person must remain on the center ladder to hold both panels in place until three panels are up and secure.** (F18.4, F18.5 and F18.6)

**C:** Starting at the bottom and working up connect Large Roof Panel Assembly to Small Roof Panel Assembly through the Rafter Corners with two 1/4 x 2-3/4" Hex Bolts (with two 1/4-5/16" large washers and one 1/4" lock nut). To align bolt holes helper in the center may have to push up the center of the panels while other helpers make sure corners are aligned. Make sure all bolts remain loose. (F18.4, F18.6 and F18.7)

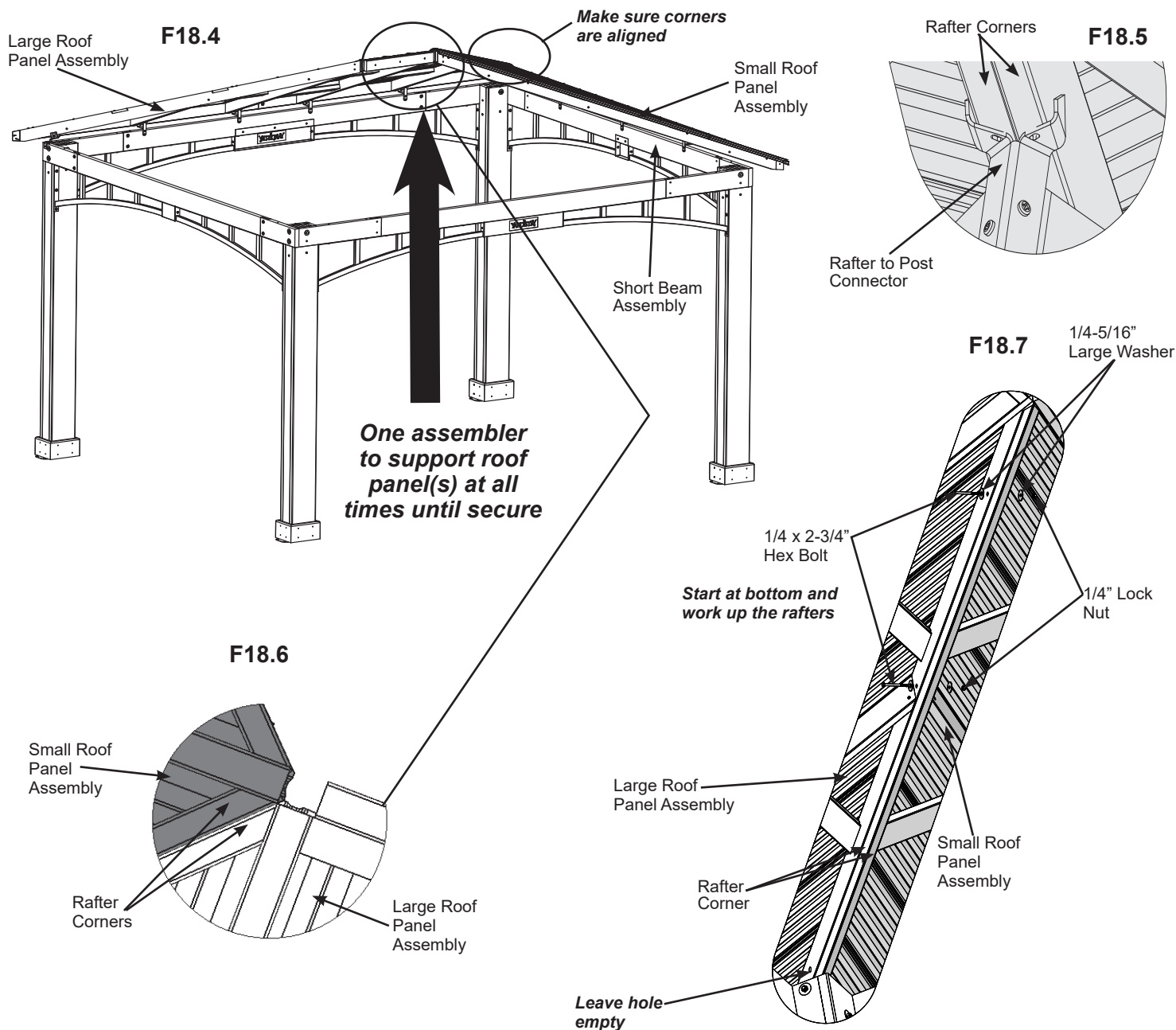

### Hardware

2 x 1/4 x 2-3/4" Hex Bolt  
(1/4-5/16" large washer x 2, 1/4" lock nut)

# Step 18: Attach Roof Panels to Frame Part 3

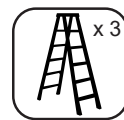

**D:** Lift second Large Roof Panel Assembly with Roof to Beam Brackets over Large Beam Assembly taking care not to drag the panel on the beams then set in place beside the Small Roof Panel Assembly. Make sure the Rafter Corners sit in Rafter to Post Connectors. (F18.8)

**E:** Starting at the bottom and working up connect Large Roof Panel Assembly to Small Roof Panel Assembly through the Rafter Corners with two 1/4 x 2-3/4" Hex Bolts (with two 1/4-5/16" large washers and one 1/4" lock nut). To align bolt holes helper on the center ladder may have to push up in the center of the panels and others make sure corners are aligned. Make sure all bolts remain loose. (F18.8 and F18.9)

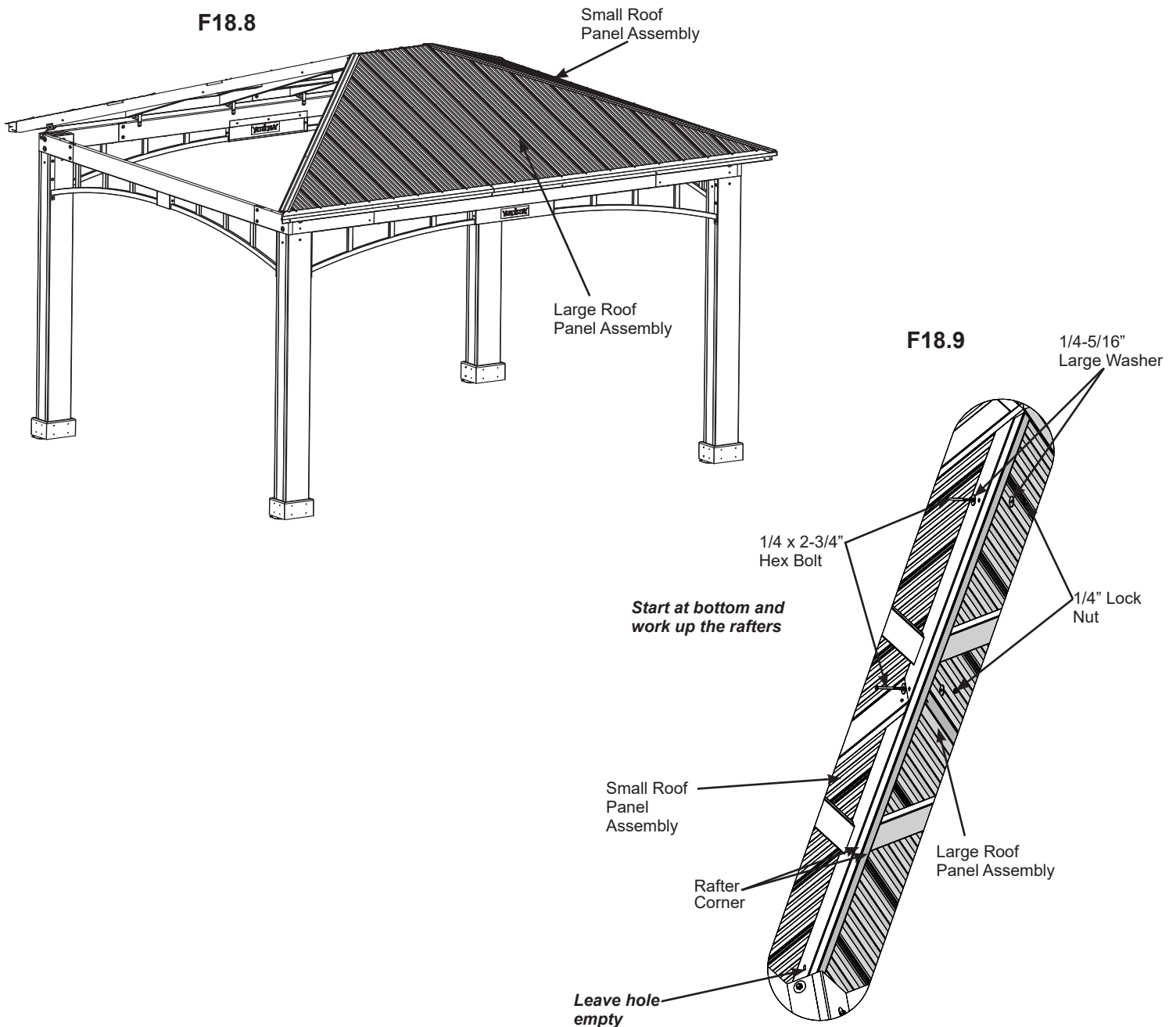

### Hardware

2 x 1/4 x 2-3/4" Hex Bolt  
(1/4-5/16" large washer x 2, 1/4" lock nut)

## Step 19: Roof Peak Assembly

**A:** Insert two Carriage Bolts with Contoured Washers through the top of Peak Cap Long, into Peak Post then Spring Clip. The Spring Clip holds the assembly together. (F19.1)

**B:** Insert one 1/4" Nut into each Peak Loop. Be careful, nut is loose and will fall out until attached to Peak Cap Assembly. (F19.2)

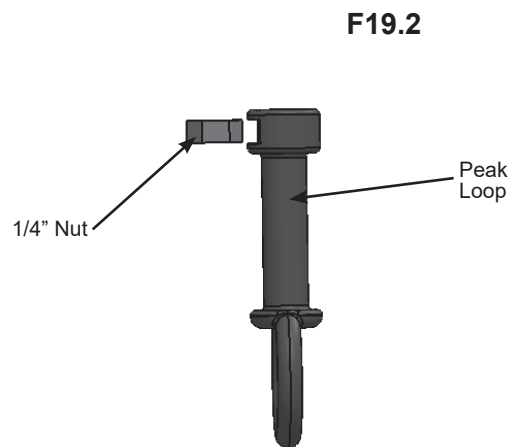
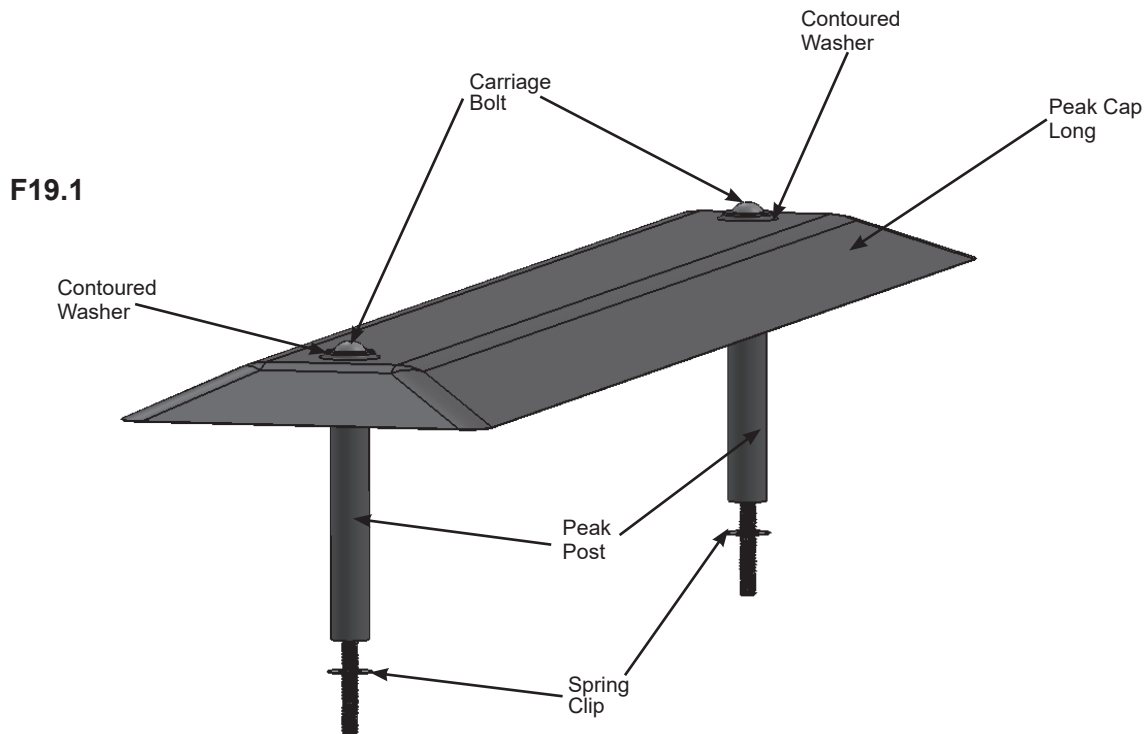

### Components:

1 x Roof Peak Set	1 x Peak Cap Long
2 x Carriage Bolt	2 x Peak Post
2 x Contoured Washer	
2 x Peak Loop	
2 x Spring Clip	
2 x 1/4" Nut	

# Step 20: Attach Roof Peak to Roof Panels



**A:** Insert Roof Peak Assembly in gap between Large and Small Roof Panels. Peak Cap Long to be lined up with Rafter Corners. (F20.1 and F20.2)

**B:** Insert two Roof Peak Brackets through each Carriage Bolt and attach Peak Loop to Carriage Bolts then twist to tighten loosely. (F20.1)

**C:** Loosely attach one set of Roof Peak Brackets to the Rafter Corners of the connected Large and Small Roof Panels in the slotted holes with four #10 x 1-1/4" Pan Screws. On the second set of Roof Peak Brackets loosely attach to the Rafter Corners of Large Roof Panels with two #10 x 1-1/4" Pan Screws. (F20.3)

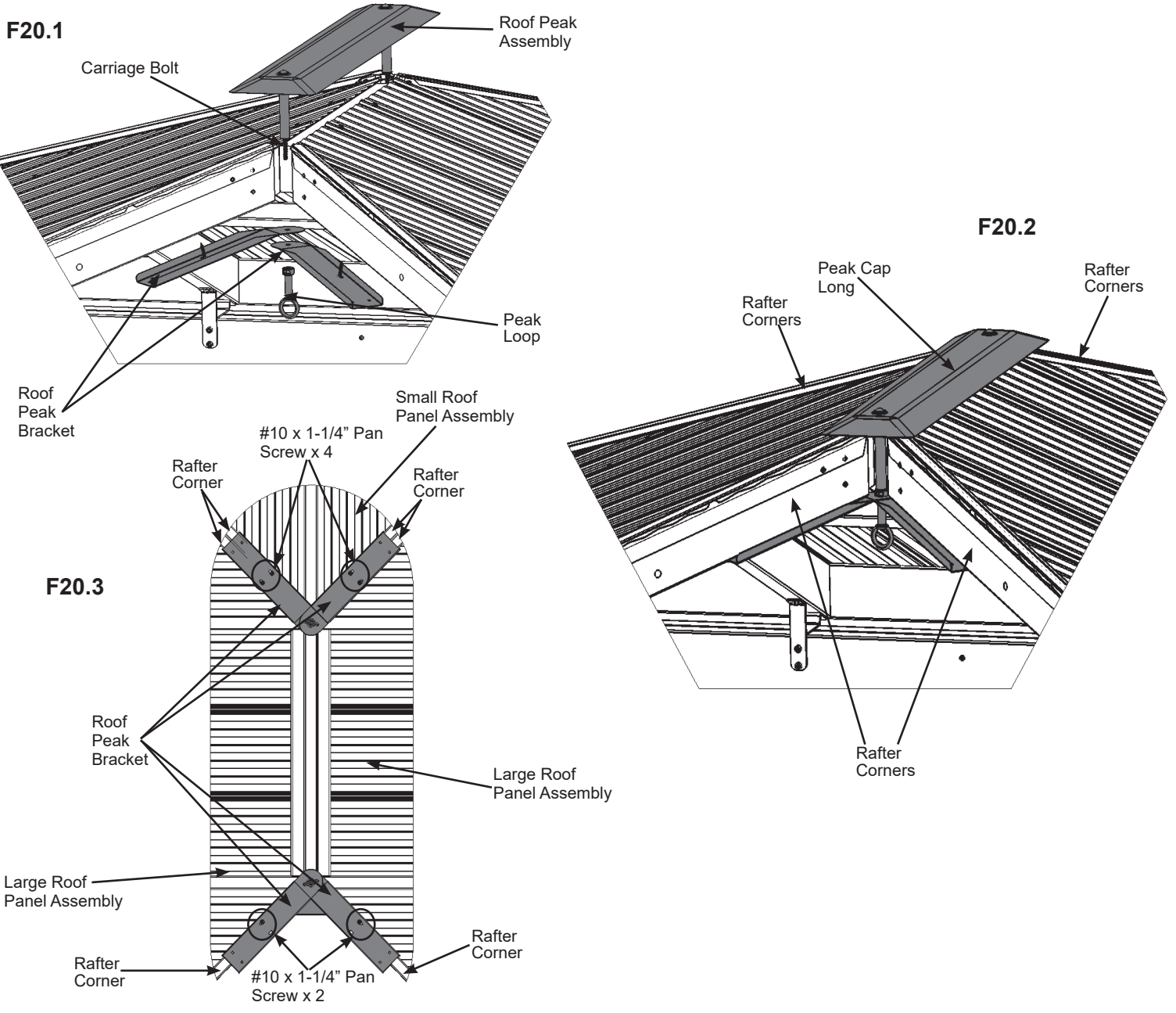

**Components:**

4 x Roof Peak Brackets

**Hardware**

6 x #10 x 1-1/4" Pan Screw Yellow

# Step 21: Attach Final Roof Panel Part 1

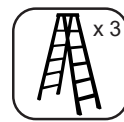

**A:** Lift last Small Roof Panel Assembly (without Roof to Beam Brackets) over Short Beam Assembly taking care not to drag the panel on the beams. Panel fits under the Peak Cap Long, push up on Peak Loop to lift Peak Cap Long. Make sure the Rafter Corners sit in Rafter to Post Connectors. The center of the other panels may have to be pushed up to fit fourth panel. (F21.1 and F21.2)

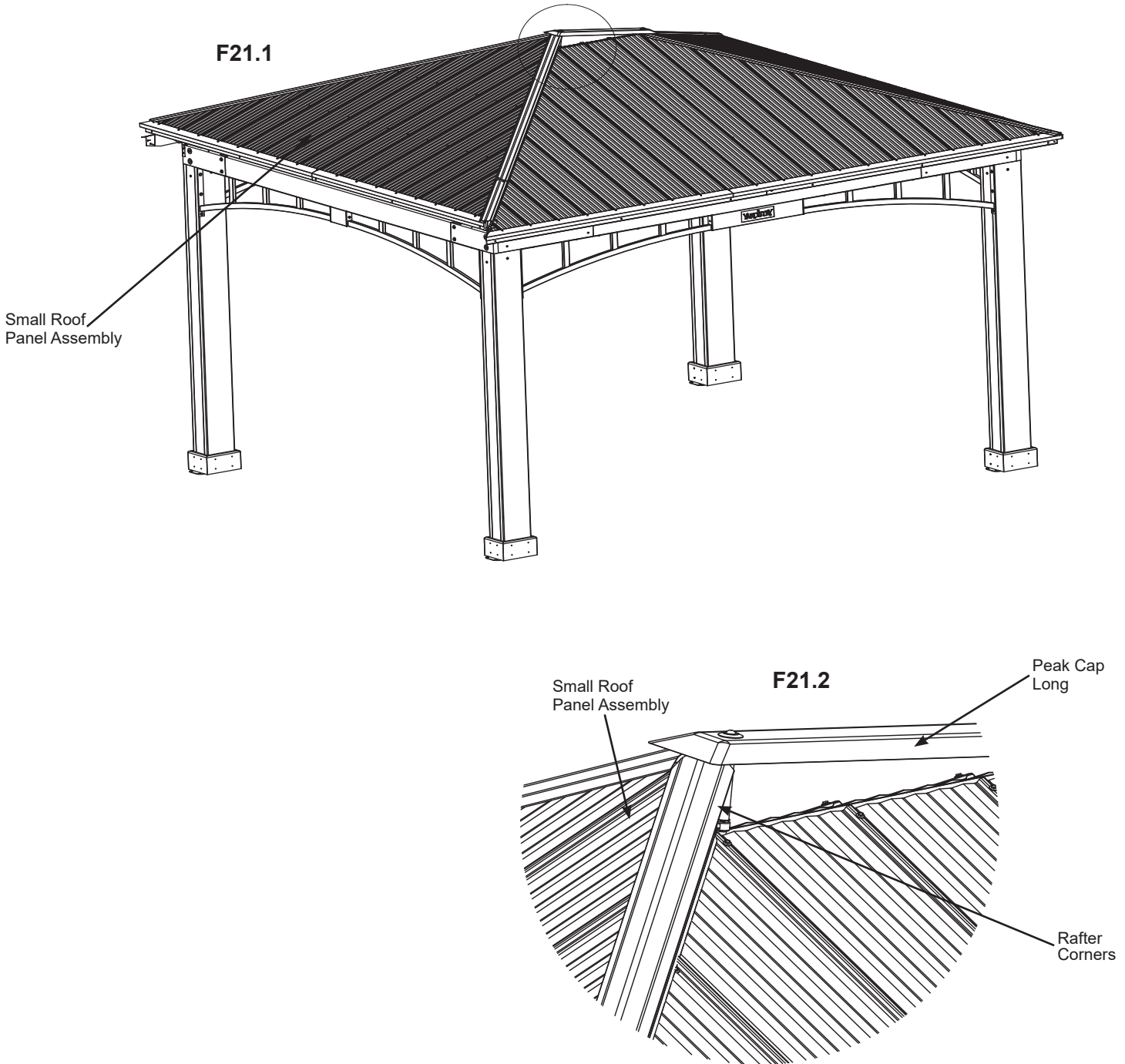

# Step 21: Attach Final Roof Panel Part 2



Remember to push up center to assist with alignment.

**B:** Starting at the bottom and working up loosely connect Roof Panel Assemblies through the Rafter Corners with two 1/4 x 2-3/4" Hex Bolts (with two 1/4-5/16" large washers and one 1/4" lock nut) per side. To align bolt holes helper on the center ladder may have to push up in the center of the panels and others make sure corners are aligned. Make sure all bolts remain loose. (F21.3 and F21.4)

*Rafter Corners should be aligned with Roof to Post Bracket.*

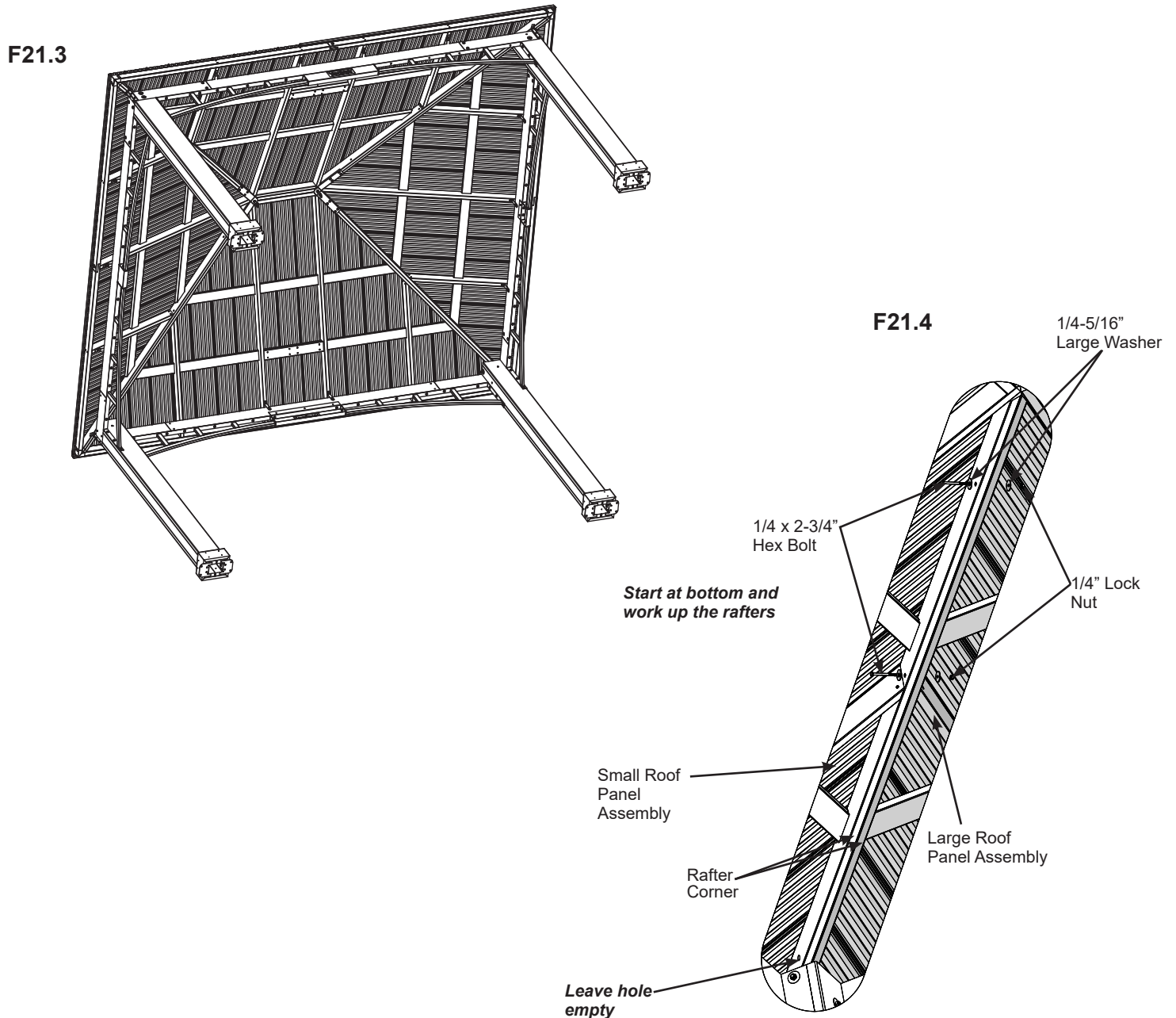

### Hardware

4 x 1/4 x 2-3/4" Hex Bolt  
(1/4-5/16" large washer x 2, 1/4" lock nut)

# Step 21: Attach Final Roof Panel Part 3



Remember to push up center to assist with alignment.

**C:** Place one Post Top Bracket LT on top of post so the holes are aligned and loosely attach using one 3/8 x 3-1/2" Hex Bolt (with two 3/8" flat washers and one 3/8" lock nut). (F21.5 and F21.6)

**D:** Repeat step C on remaining three corners to install one more Post Top Bracket LT and two Post Top Bracket RT's. (F21.5, F21.6 and F21.7)

F21.5

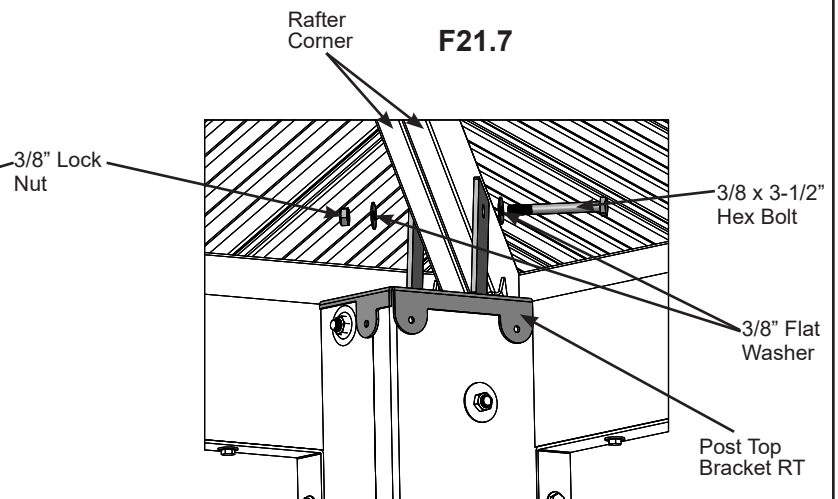
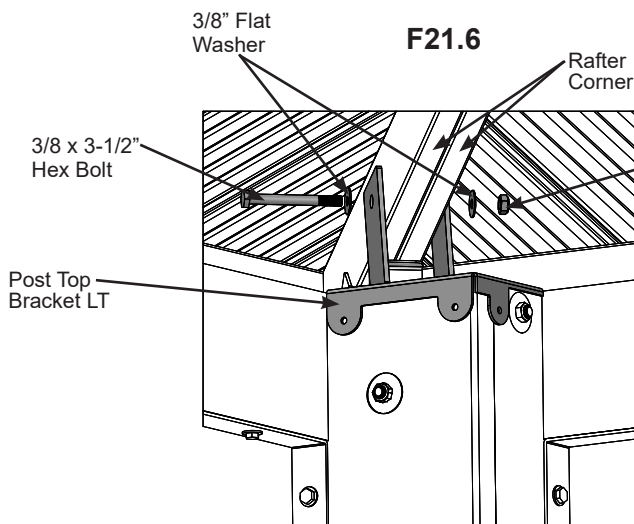
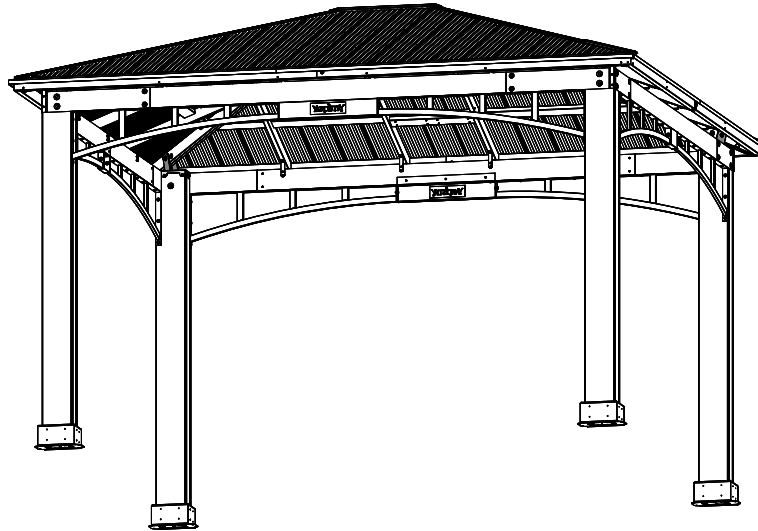

**Components:**

- 2 x Post Top Bracket LT
- 2 x Post Top Bracket RT

**Hardware**

- 4 x 3/8 x 3-1/2" Hex Bolt  
(3/8" flat washer x 2, 3/8" lock nut)

# Step 21: Attach Final Roof Panel Part 4

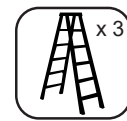

Remember to push up center to assist with alignment.

**E:** Attach Post Top Bracket LT and Post Top Bracket RT's to Post using three #12 x 1-1/2" Pan Screws per bracket. Ensure Post Top Brackets are tight to top of Post. (F21.8, F21.9 and F21.10)

**F:** Tighten all Bolts in Corner Rafters.

F21.8

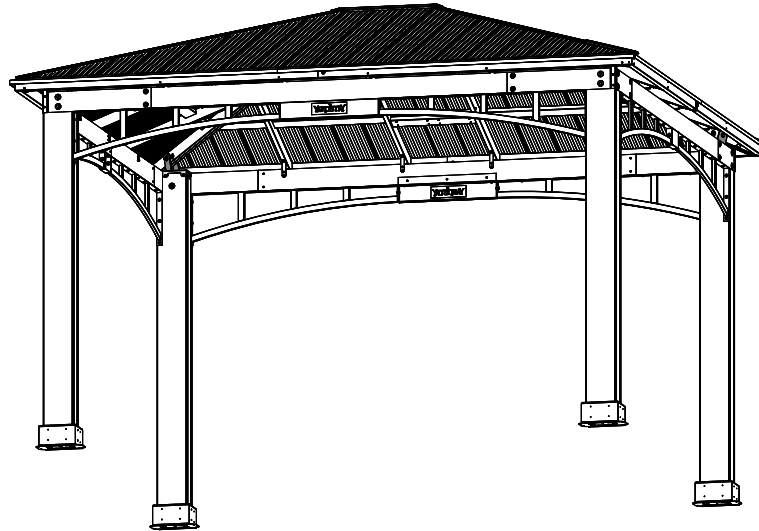

F21.9

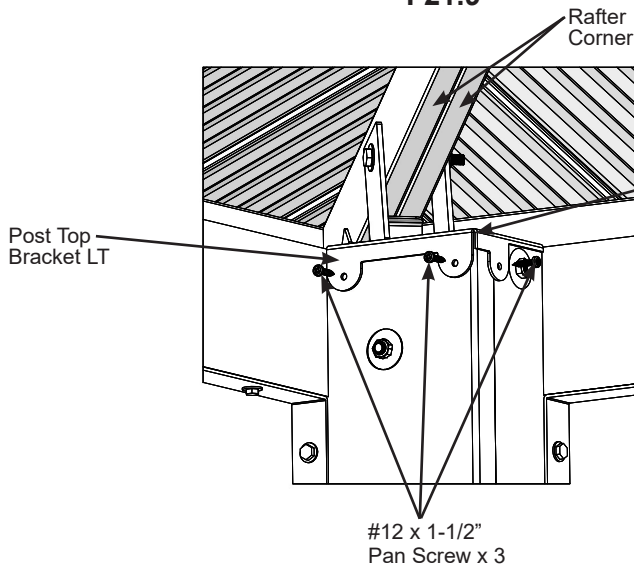

F21.10

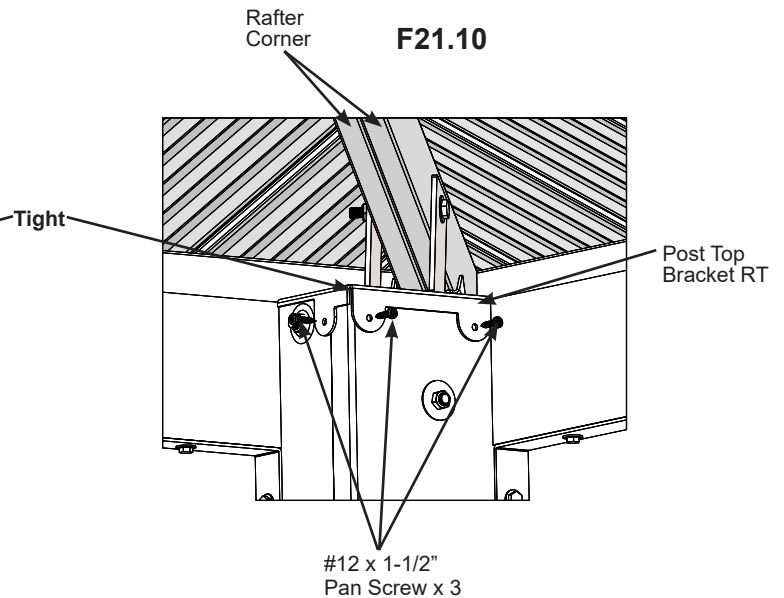

## Hardware

12 x #12 x 1-1/2" Pan Screw Black

# Step 21: Attach Final Roof Panel Part 5

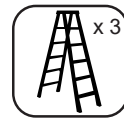

**G:** On the Small Roof Rafter Assembly just installed, centered on the bottom of (442) Rafter Short Right, (441) Rafter Short Left and (440) Rafter attach one Roof to Beam Bracket per board with two #12 x 1-1/2" Pan Screws per bracket. (F21.11)

**F21.11**

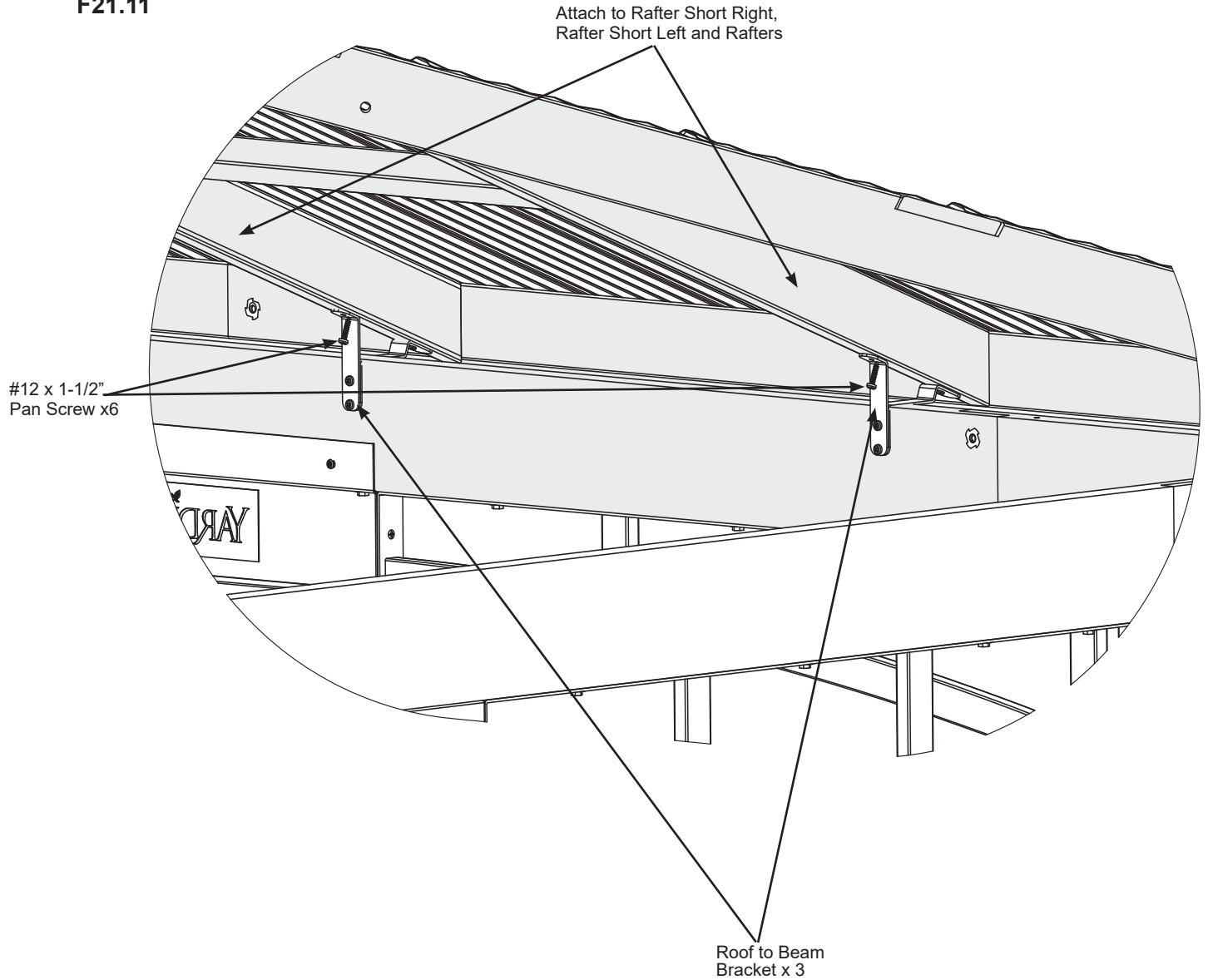

### Components

3 x Roof to Beam Bracket

### Hardware

6 x #12 x 1-1/2" Pan Screw Yellow

## Step 22: Secure Roof Corners

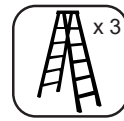

**A:** Make sure middle Roof to Beam Brackets are flush and tight to the Beam Assemblies. Lift in center if needed.

**B:** From outside the assembly attach Roof Panel Assemblies together at the Fascia Beam Assembly Ends with two #8 x 2-1/2" Wood Screws per corner. A helper may need to lift the center of the roof to bring the corners tight together. (F22.1 and F22.2)

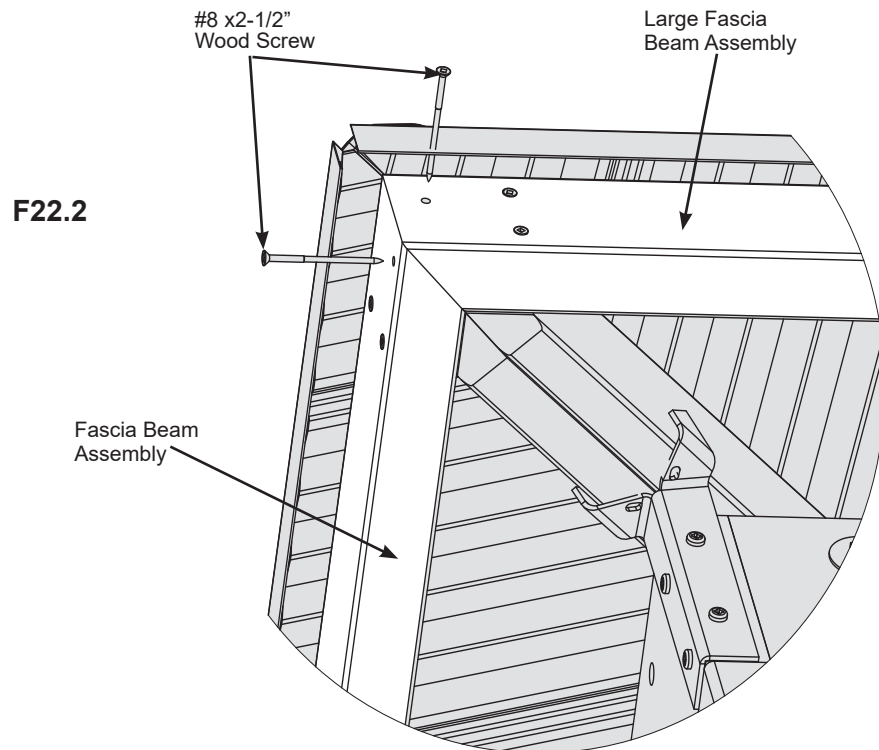
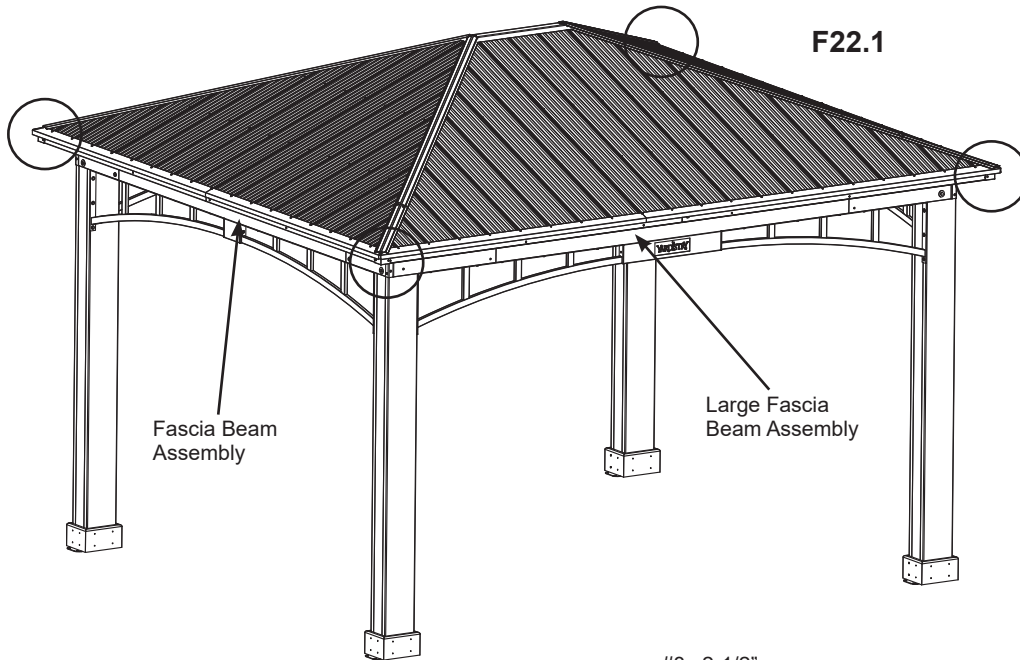

### Hardware

8 x #8 x 2-1/2" Wood Screw

# Step 23: Attach Corner Caps

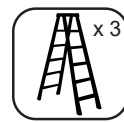

**A:** At each corner place one Corner Cap tight to Fascia Assemblies, push up so the bottom is tight to the bottom of the assemblies then attach with four #8 x 3/4" Sheet Metal Screws per Corner Cap. (F23.1 and F23.2)

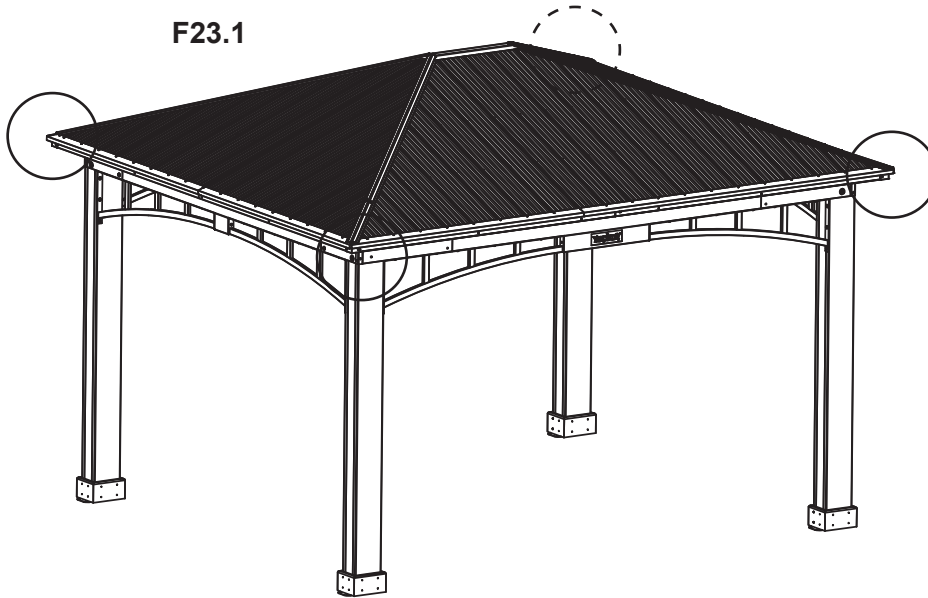

F23.1

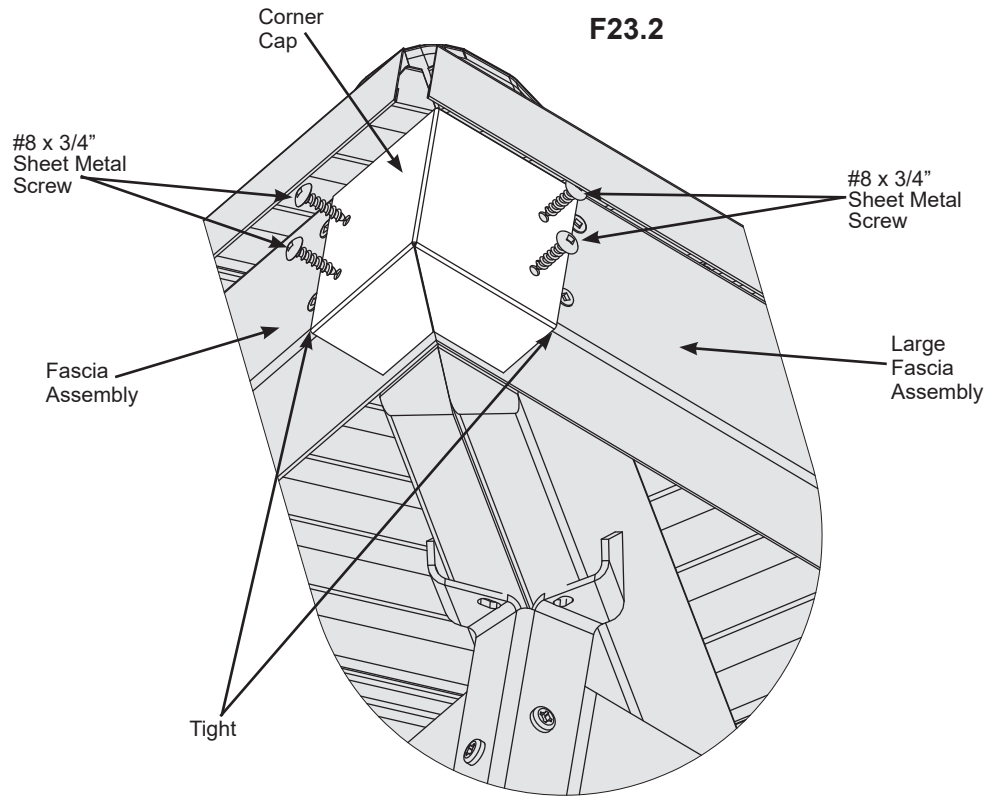

F23.2

### Components

4 x Corner Cap

### Hardware

16 x #8 x 3/4" Sheet Metal Screw

# Step 24: Secure Roof to Beam Brackets

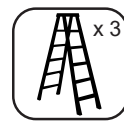

**A:** From inside the assembly attach Roof to Beam Brackets to Beam Assemblies with two #12 x 1-1/2" Pan Screw per bracket. (F24.1 and F24.2)

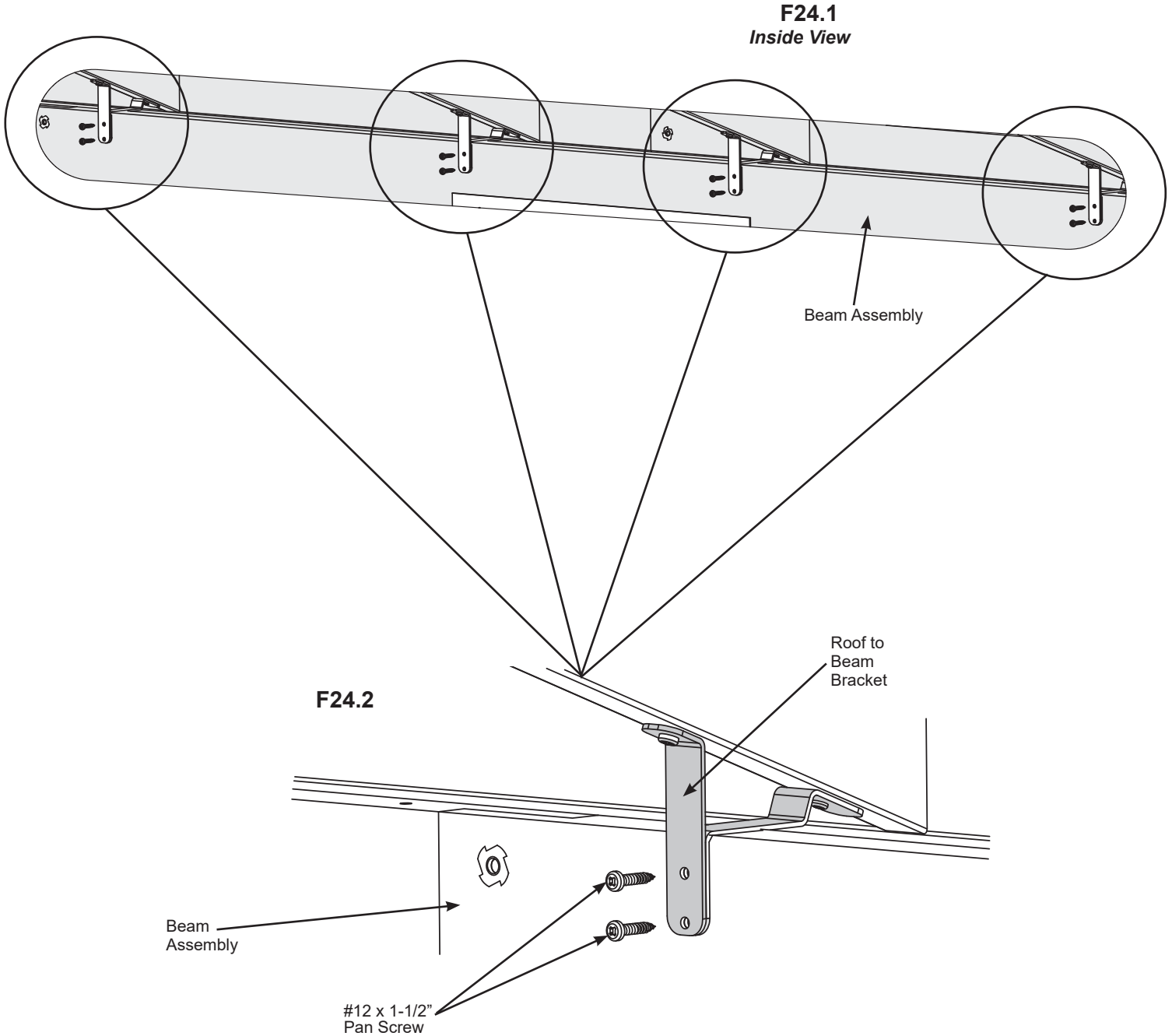

### Hardware

28 x #12 x 1-1/2" Pan Screw Yellow

# Step 25: Secure Roof Peak Brackets



**A:** Tighten the six screws in Roof Peak Brackets then attach to Corner Rafters in the remaining holes with ten #10 x 1-1/4" Pan Screws. (F25.1)

**B:** Remove Peak Loop and install one Peak Reinforcement Bracket per Peak Loop then install Peak Loop. (F25.2)

**C:** Attach Peak Reinforcement Brackets using six #10 x 1 1/4 Pan Screws per Bracket. (F25.2)

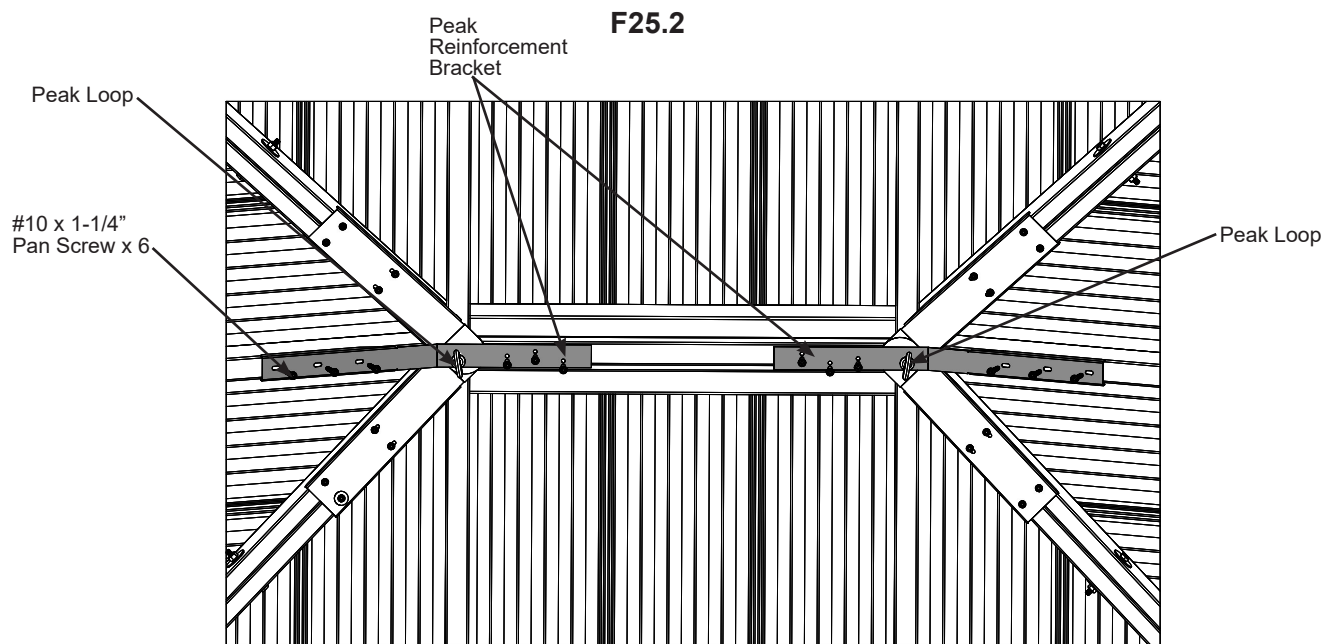
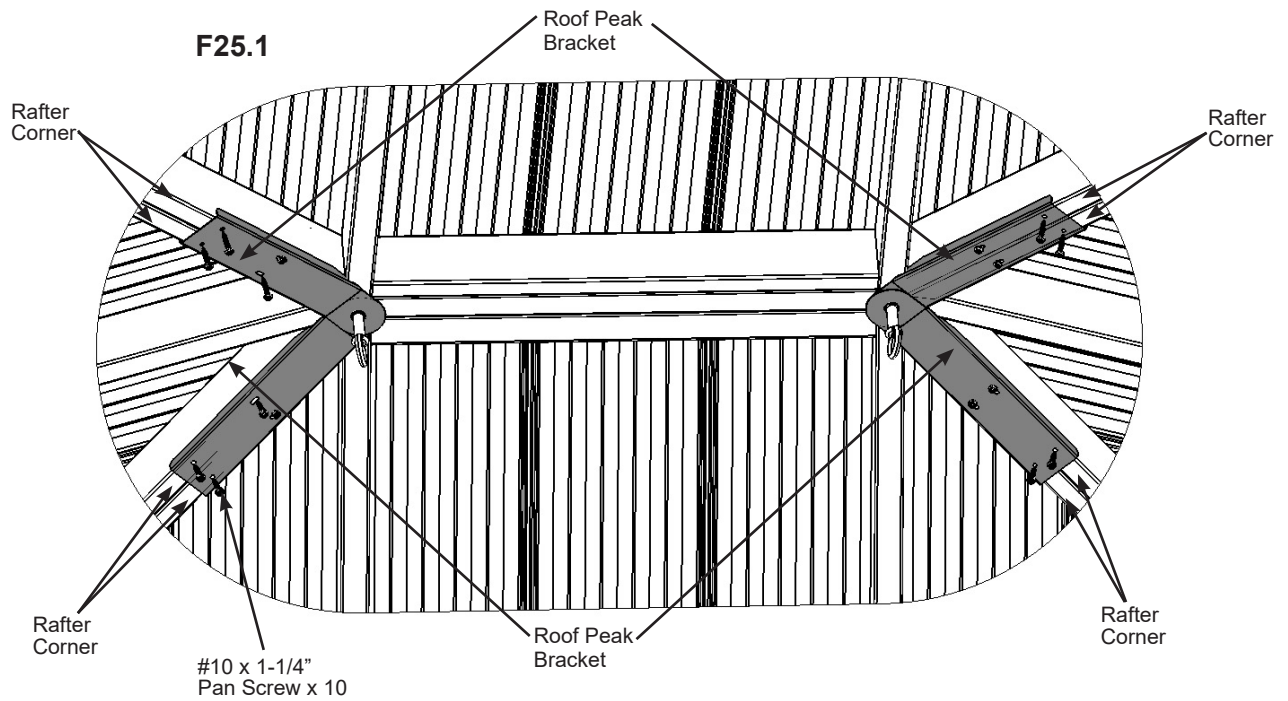

## Components

2 x Peak Reinforcement Bracket

## Hardware

22 x #10 x 1-1/4" Pan Screw

# Step 26: Attach Ridge Caps to Roof Panels

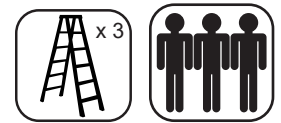

**A:** Slide one Ridge Cap Long 81.5 over the Ridge Clips, with cut end leading, on each corner of the assembly from the bottom up. Slide Ridge Cap Short 25.2 over the Ridge Clips leading with the insert end to push the Ridge Cap Long 81.5 to the top, lifting Peak Cap Long by pushing up the Peak Loop so Ridge Cap Long 81.5s fit under Peak Cap Long. Attach with two #8 x 3/4" Sheet Metal Screws per Ridge Cap set. (F26.1, F26.2, F26.3, F26.4 and F26.5)

**B:** Tighten Loop to secure Roof Peak Set.

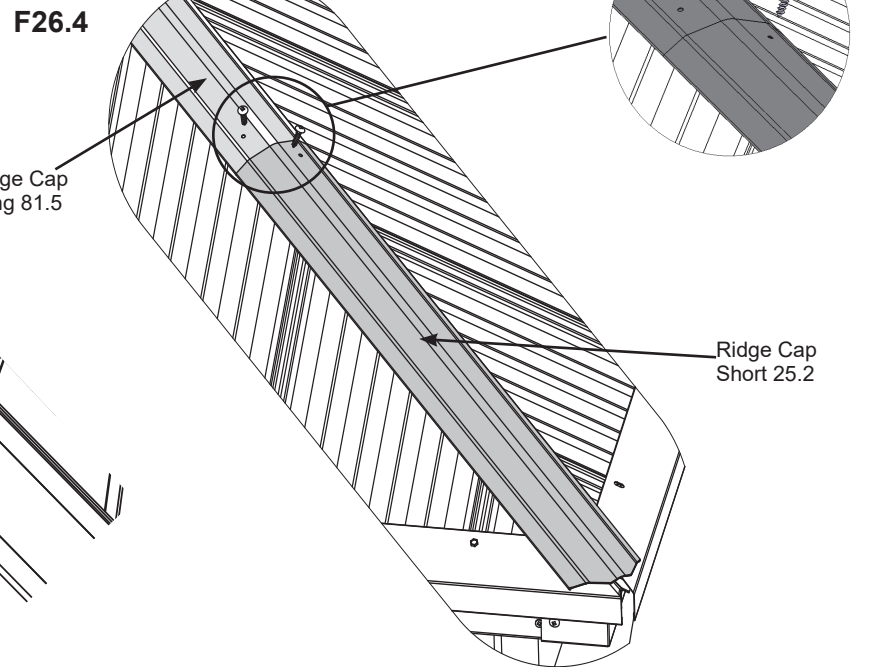
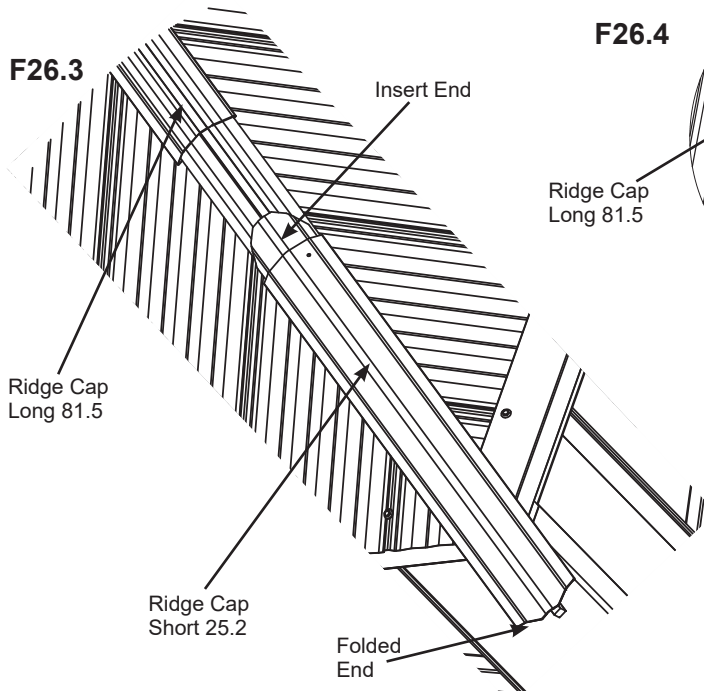
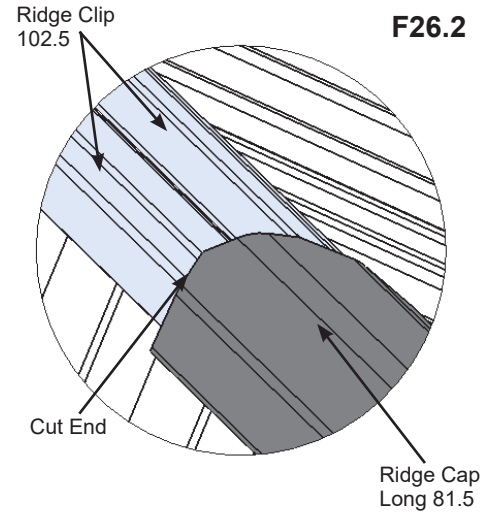
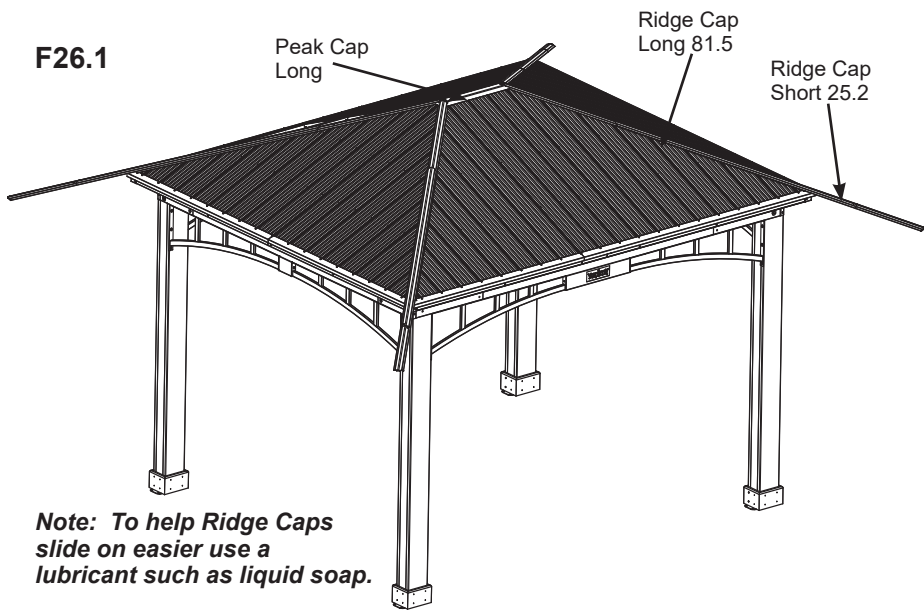

### Components:

- 4 x Ridge Cap Long 81.5
- 4 x Ridge Cap Short 25.2

### Hardware

- 8 x #8 x 3/4" Sheet Metal Screw

## Step 27: Secure Rafter to Post Connectors

**A:** Attach Rafter to Post Connectors to Rafter Corners with two #10 x 1-1/4" Pan Screws - Black per connector. (F27.1 and F27.2)

F27.1

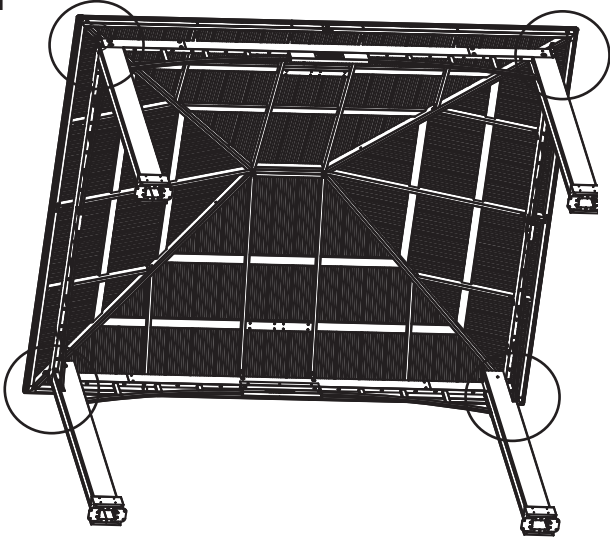

F27.2

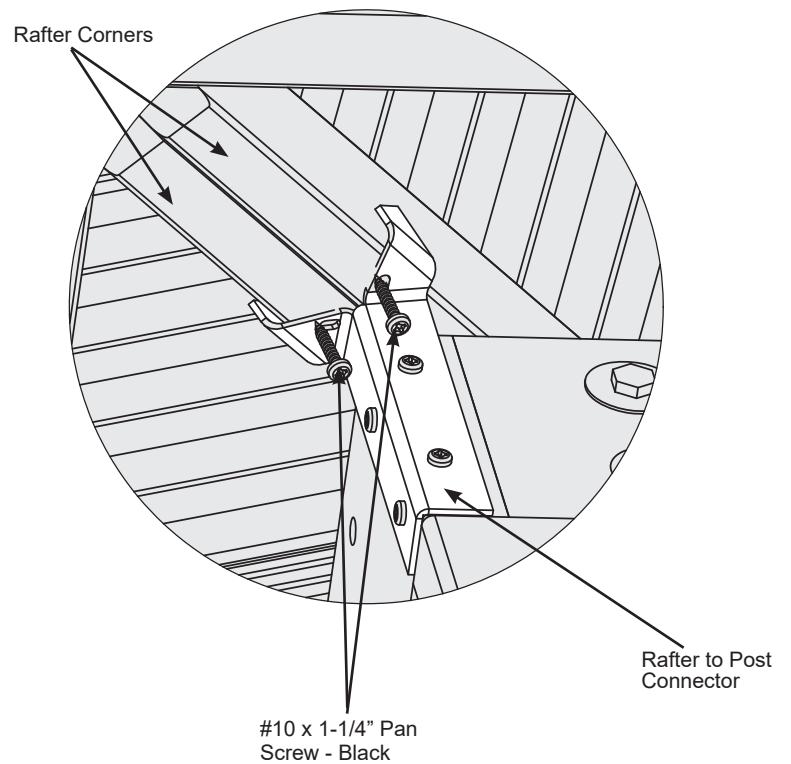

### **Hardware**

**8 x #10 x 1-1/4" Pan Screw - Black**

# Step 28: Attach Tie Wrap Brackets and Ties

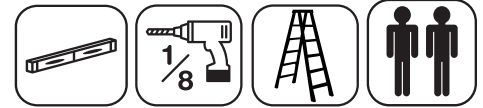

**A:** Attach one Tall Tie Wrap Bracket to each end of one (461) Tie with one #10 x 1-1/4" Pan Screw per bracket using the inside holes. (461) Tie is tight to end of bracket. (F28.1, F28.2 and F28.3)

**B:** With a helper place (461) Tie with brackets against a (440) Rafter on each Large Roof Panel so (461) Tie is tight to (440) Rafters and level. Attach Tall Tie Wrap Bracket to (440) Rafters with three #10 x 1-1/4" Pan Screws on both sides of each bracket. (F28.1, F28.2 and F28.3)

**C:** Pre-drill with a 1/8" drill bit and secure Tall Tie Wrap Brackets to (461) Tie and (440) Rafter with one #10 x 2-1/2" Pan Screw per bracket. (F28.1, F28.2 and F28.3)

**D:** Repeat Steps A to C for a second (461) Tie.

F28.1

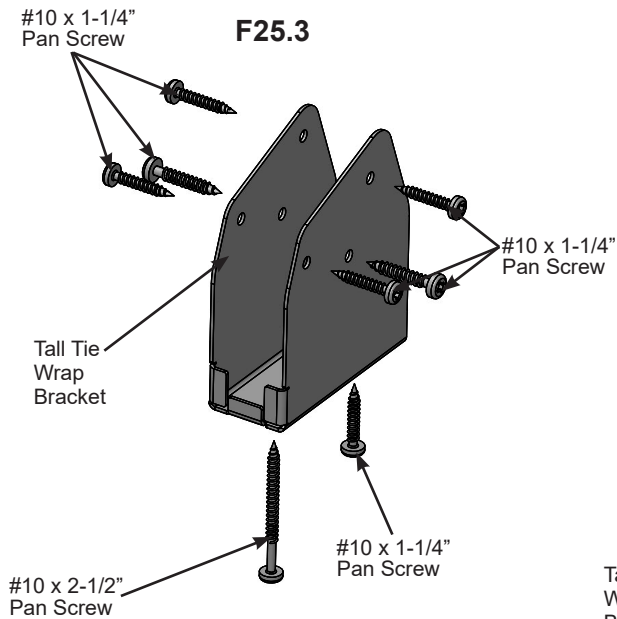
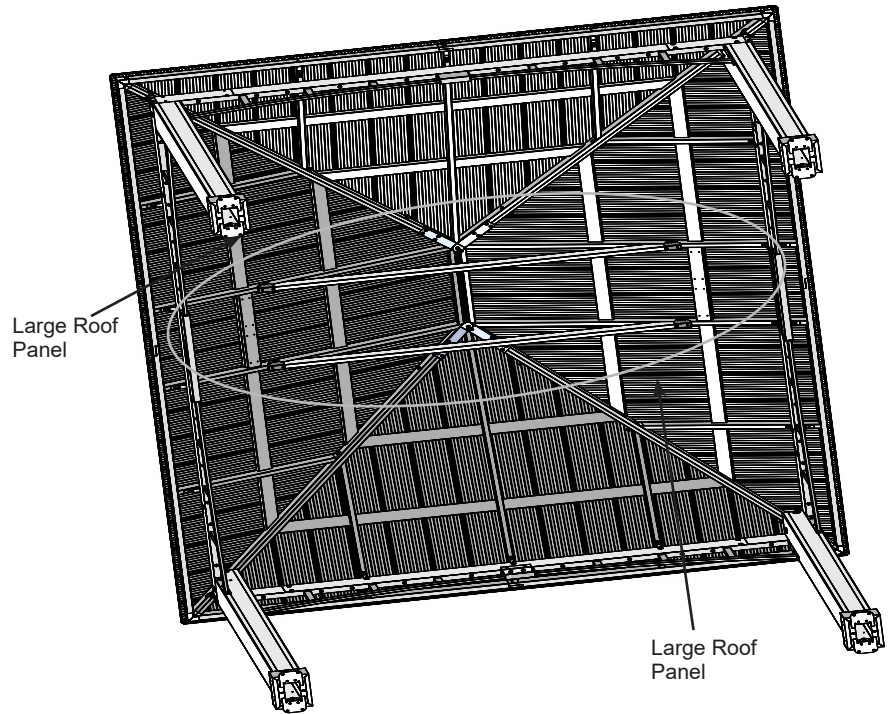

F25.2

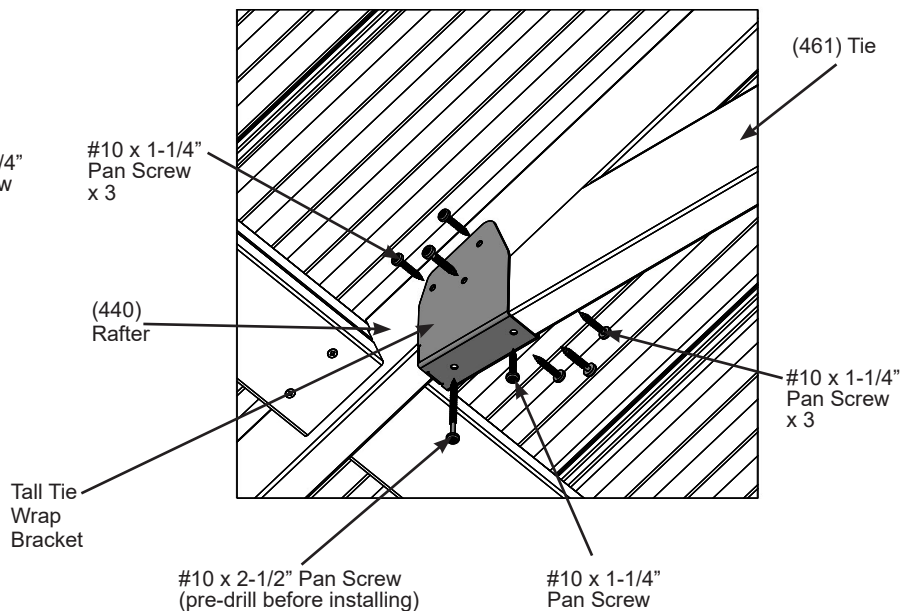

**Wood Parts**

2 x (461) Tie

**Components:**

4 x Tall Tie Wrap Bracket

**Hardware**

28 x #10 x 1-1/4" Pan Screw  
4 x #10 x 2-1/2" Pan Screw

# Step 29: Metal Hooks and Plaque Part 1



**A:** Two 50 mm Hooks are included with this unit for attaching wiring. They can be placed anywhere along the Rafter Corners as needed. Pre-drill with a 1/8" drill bit before installing. (F29.1 and F29.2)

**B:** One Eye Lag is included with this unit for hanging items with a maximum weight of 22 lbs (10 kg). Pre-drill with a 1/8" drill bit into center of (463) Spacer Top then install Eye Lag. (F29.1 and F29.3)

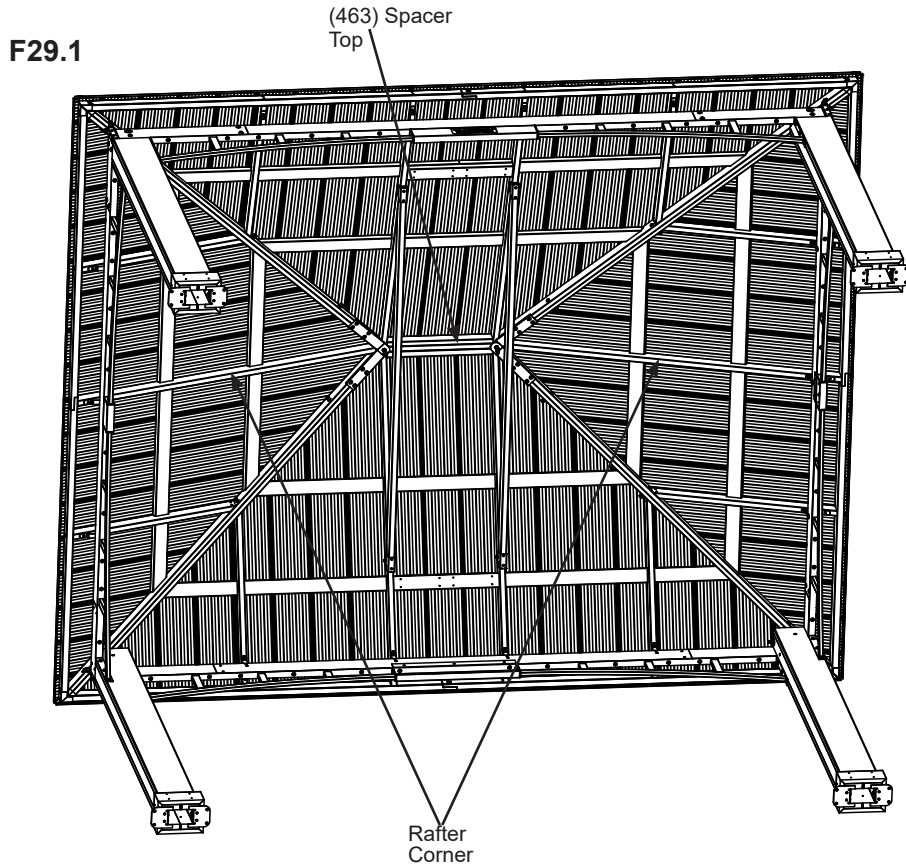

**Note: DO NOT ATTACH ANY PRODUCT WHICH WEIGHS GREATER THAN 22 LBS (10 KG) TO THE EYE LAG**

**Note: We have provided two 50 mm hooks for optional use to hold in place any wires if required. These hooks are not designed to hold any heavy products such as lights, flower pots, etc.**

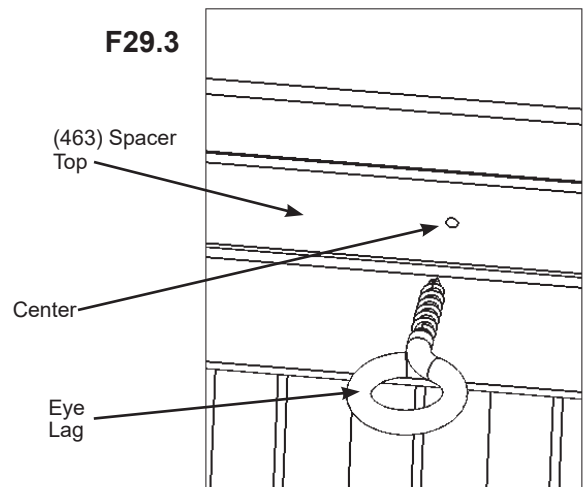

### Hardware

- 2 x 50 mm Hooks
- 1 x Eye Lag

## Step 29: Metal Hooks and Plaque Part 2

C: Attach Gazebo ID Plaque to a prominent location on your gazebo with two #10 x 1-1/4" Pan Screws. This provides warnings concerning safety and important contact information. (F29.4 and F29.5)

F29.4

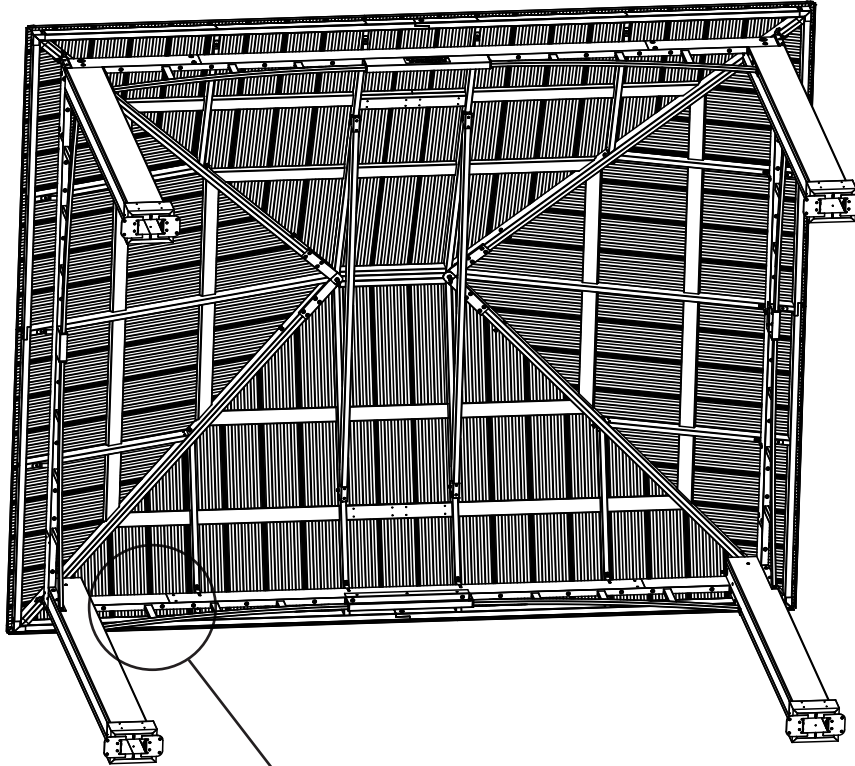

#10 x 1-1/4"  
Pan Screw

F29.5

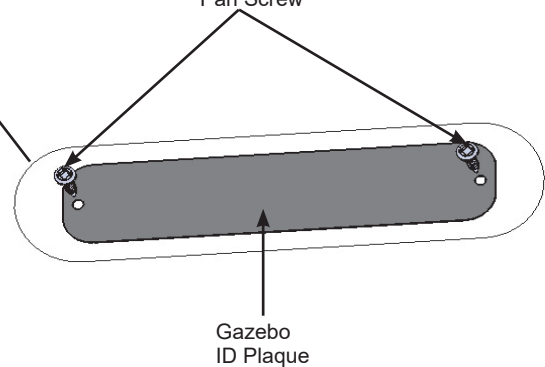

### Components

1 x Gazebo ID Plaque

### Hardware

2 x #10 x 1-1/4" Pan Screw

# YARDISTRY®

Yardistry® 375 Sligo Road West, P.O. Box 10, Mount Forest, ON Canada N0G 2L1

Distributed by:  
Costco Wholesale Corporation  
P.O. Box 34535  
Seattle, WA 98124-1535  
USA  
1-800-774-2678  
www.costco.com

Costco Wholesale Canada Ltd.\*  
415 W. Hunt Club Road  
Ottawa, Ontario  
K2E 1C5, Canada  
1-800-463-3783  
www.costco.ca  
\* faisant affaire au Québec sous  
le nom les Entrepôts Costco

Importado por:  
Importadora Primex S.A. de C.V.  
Blvd. Magnocentro No. 4  
San Fernando La Herradura  
Huixquilucan, Estado de México  
C.P. 52765  
RFC: IPR-930907-S70  
(55)-5246-5500  
www.costco.com.mx

Costco Wholesale Australia Pty Ltd  
17-21 Parramatta Road  
Lidcombe NSW 2141  
Australia  
www.costco.com.au

Costco Wholesale UK Ltd /  
Costco Online UK Ltd  
Hartspring Lane  
Watford, Herts  
WD25 8JS  
United Kingdom  
01923 213113  
www.costco.co.uk

Costco Wholesale Spain S.L.U.  
Polígono Empresarial Los Gavilanes  
C/ Agustín de Betancourt, 17  
28906 Getafe (Madrid) España  
NIF: B86509460  
900 111 155  
www.costco.es

Costco Wholesale Iceland ehf.  
Kauptún 3-7, 210 Gardabaer  
Iceland  
www.costco.is

Costco France  
1 avenue de Bréhat  
91140 Villebon-sur-Yvette  
France  
01 80 45 01 10  
www.costco.fr

Costco Wholesale Japan Ltd.  
2 Kakuchi, 2 Gaiku, Kaneda-Nishi  
361 Urakura, Kisarazu shi  
Chiba, 292-0007 Japan  
0570-200-800  
www.costco.co.jp

Costco Wholesale Korea, Ltd.  
40, Iljik-ro  
Gwangmyeong-si  
Gyeonggi-do, 14347, Korea  
1899-9900  
www.costco.co.kr

Costco Wholesale New Zealand Limited  
2 Gunton Drive  
Westgate  
Auckland 0814  
New Zealand  
www.costco.co.nz

Costco (China) Investment Co., Ltd.  
Room 01 Mezzanine  
No. 5178, Kang Xin Highway  
Pudong New District  
Shanghai  
China 201315  
+86-21-6257-7065

Costco Wholesale Sweden AB  
Box 614  
114 11 Stockholm  
Sweden  
www.costco.se

MADE IN CHINA / FABRIQUÉ EN CHINE / HECHO EN CHINA







## Customer Registration Card - Carte d'inscription du client - Tarjeta de Registro del Cliente

First Name - Prénom - Primer Nombre	Initial - Initiale - Inicial	Last Name - Nom de famille - Apellido

Street - Rue - Calle	PO Box - Boîte postale - Casilla postal	Apt. No. - App.

City - Ville - Ciudad	State/Province - État/Province - Estado/Provincia

ZIP/Postal Code - ZIP/Code postal - Código Postal	Country - Pays - País

E-mail Address - Adresse courriel - Dirección de E-mail	Telephone Number - N° de téléphone - No. de Teléfono

Model Name - Nom du modèle - Nombre del Modelo	Model Number (from front cover) - N° du modèle (page de couverture) - Número de Modelo (de la portada)

Date of Purchase - Date d'achat - Fecha de Compra (mm/dd/yyyy) (mm/jj/aaaa) (mm/dd/aaaa)	Place of Purchase - Lieu d'achat - Comprado a

Comments - Commentaires - Comentarios :

### Mail To - Envoyer par courrier à - Enviar por Correo a:

Yardistry  
375 Sligo Road West, PO Box 10  
Mount Forest, Ontario, Canada, N0G 2L0  
Attention: Consumer Relations  
À l'attention de : Service à la clientèle  
Atención a: Servicio de Atención al Cliente

### Online Registration - Enregistrement en ligne - Registro online:

[www.yardistrystructures.com/warranty](http://www.yardistrystructures.com/warranty)

1.888.509.4382

Hours/ Heures/ Horas: 8:30 am - 5:00 pm EST  
(excl. holidays/ hors jours fériés/ excepto los días festivos)

Téléfono no Válido en México

English and French Spoken / Anglais et français parlés / Inglés y francés hablado

Yardistry would like to say "Thank you" for your time and feedback.

Yardistry aimerait vous remercier d'avoir pris le temps de répondre au sondage.

Yardistry quiere "Agradecerle" por su tiempo y su opinión.